

1. DESCRIPTION

The BA577E-SS is a one input general purpose instrument in a rugged 316 stainless steel enclosure that can be configured as a Timer or as a Clock. As a Timer the BA577E-SS is able to measure and display the elapsed time between external events, or control external events via two optional factory fitted control outputs. When configured as a Clock the BA577E-SS displays local time and the optional control outputs can turn on and off twice in each twenty four hour period.

This abbreviated instruction sheet is intended to assist with installation, a comprehensive instruction manual describing system design and configuration may be downloaded from the BEKA website or may be requested from the BEKA sales office.

2. INSTALLATION.

Cut-out dimensions

Mandatory to achieve an IP66 seal between instrument and panel and to maintain certification of panel enclosure in which it is mounted.

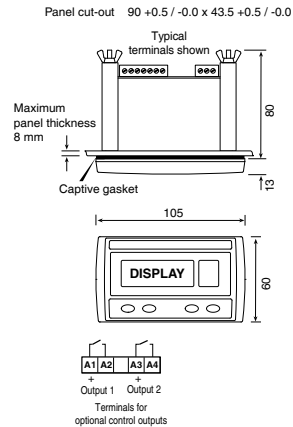

Support panel wiring to prevent vibration damage
Fig 1 Cut-out dimensions and terminals

**Abbreviated instructions for
BA577E-SS Rugged one input
general purpose Timer or Clock**

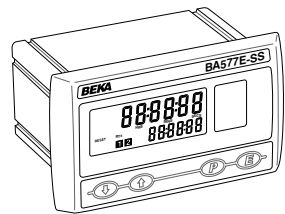

Issue 3
27th April 2017

BEKA associates Ltd. Old Charlton Rd, Hitchin, Hertfordshire,
SG5 2DA, UK Tel: +44(0)1462 438301 Fax: +44(0)1462 453971
e-mail: sales@beka.co.uk web: www.beka.co.uk

The BA577E-SS is CE marked to show compliance with the EMC Directive 2014/30/EU.

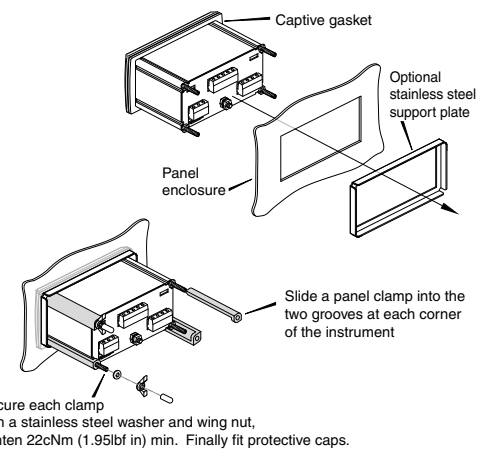

Fig 2 Installation procedure

EMC

For specified immunity all wiring should be in screened twisted pairs with screens earthed at one point.

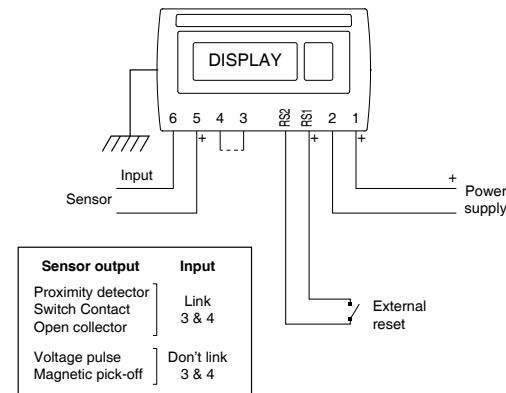

Fig 3 Typical system

Scale card

The Timer or Clock units of measurement are shown on a printed scale card visible through a window at the right hand side of the display. The scale card is mounted on a flexible strip that is inserted into a slot at the rear of the instrument as shown below

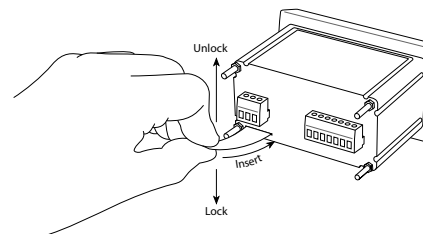

Fig 4 Inserting flexible strip carrying scale card into slot at the rear of Timer or Clock.

Thus the scale card can easily be changed without removing the Timer or Clock from the panel or opening the instrument enclosure.

New Timer or Clocks are supplied with a printed scale card showing the requested units of measurement, if this information is not supplied when the Timer or Clock is ordered a blank card will be fitted.

A pack of self-adhesive scale cards printed with common units of measurement is available as an accessory from BEKA associates. Custom printed scale cards can also be supplied.

To change a scale card, unclip the protruding end of the flexible strip by gently pushing it upwards and pulling it out of the enclosure. Peel the existing scale card from the flexible strip and replace it with a new printed card, which should be aligned as shown below. Do not fit a new scale card on top of an existing card.

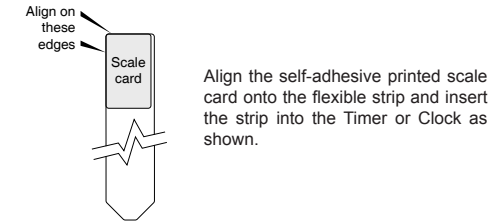

Fig 5 Fitting scale card to flexible strip

3. OPERATION

The Timer or Clock is controlled by four front panel push buttons. When in the Timer operating mode they have the following functions:

- [P] + [E]** Access to configuration menu.
- [▼]** When local control is enabled starts the Timer
- [▲]** When local control is enabled stops the Timer.
- [E] + [▲]** Shows the grand total (run time) in hours and tenths of an hour irrespective of Timer configuration. If buttons are held for longer than ten seconds the grand total may be reset to zero if the grand total reset sub-function [Lr Reset] is enabled in the [Lr rSEt] configuration function.

To reset the grand total to zero from the display mode press the **[E] + [▲]** buttons for ten seconds until [Lr.no] is displayed, using the **[▼]** or **[▲]** button change the display to [Lr.rSEt] and press **[E]**.

- [▼] + [▲]** To reset the Timer to zero or to the set time 5Et t depending on whether the Timer is configured to *time-up* or *time-down* press the **[▼] + [▲]** buttons simultaneously for more than three seconds. This is a configurable function.
- [P] + [▲]** When enabled in the configuration menu, operating these two buttons simultaneously provides direct access to the set time 5Et t and allows adjustment when the timer is in the display mode.
- [P] + [▼]** Shows in succession, firmware version number, instrument function ELAPSE or [LoC] and any output accessories that are fitted:
- R Dual Control Outputs

See full instruction manual for description of use when configured as a Clock

4. CONFIGURATION

Timer or Clocks are supplied configured as requested at time of ordering, if not specified default Timer configuration will be supplied but can easily be changed on-site.

Fig 6 shows the location of each function within the menu when configured as a Timer with a brief summary of the function. Please refer to the full instruction manual for detailed configuration information, description of the optional outputs and the menu when configured as a Clock.

Access to the configuration menu is obtained by pressing the **P** and **E** buttons simultaneously. If the Timer or Clock's security code is set to default 0000 the first parameter **Functio**n will be displayed. If the instrument is protected by a security code, **Code** will be displayed. The four digit code must be entered to gain access to the menu.

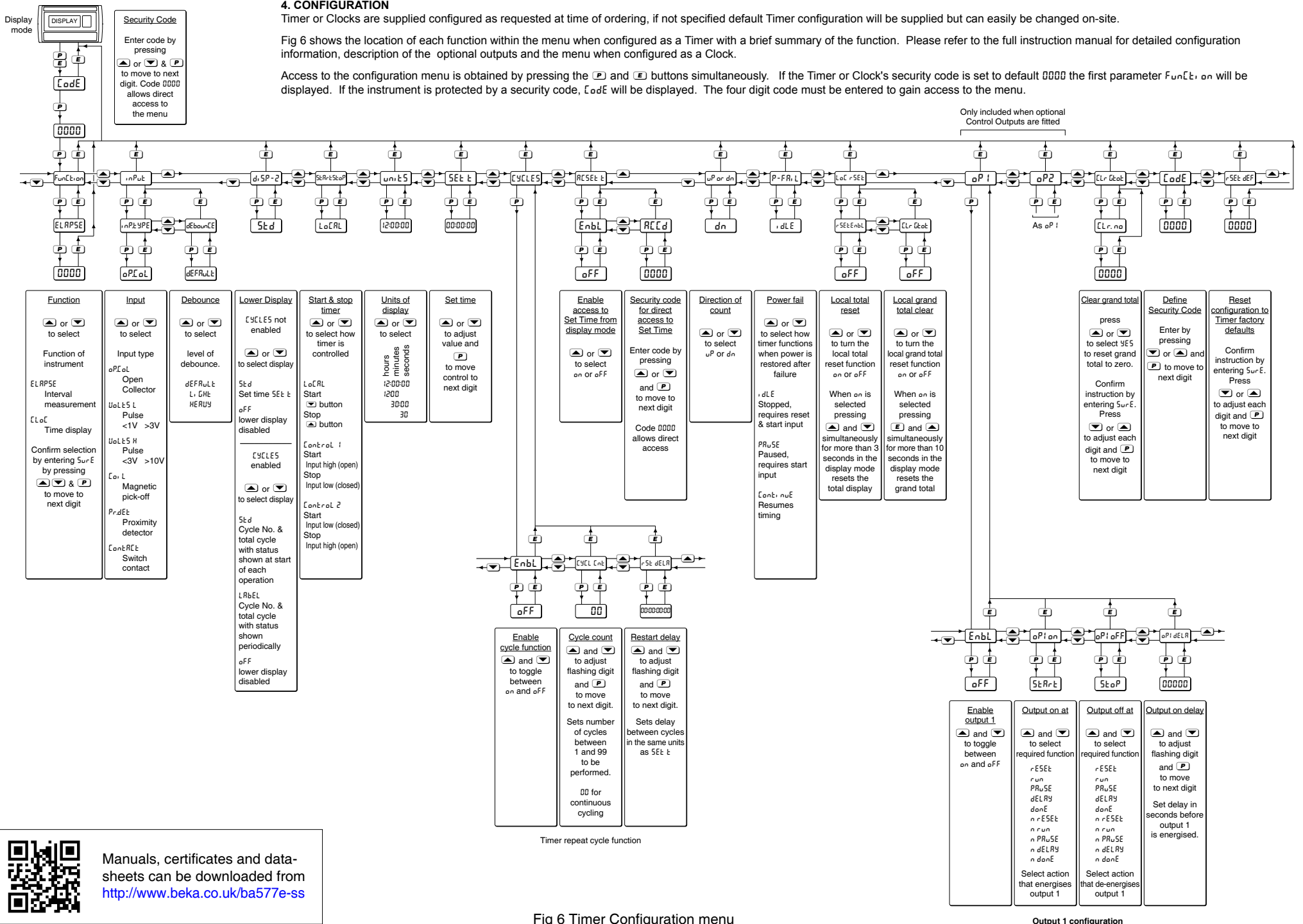

Fig 6 Timer Configuration menu



Manuals, certificates and data-sheets can be downloaded from <http://www.beka.co.uk/ba577e-ss>