

1. DESCRIPTION

The BA517E and BA518E are panel mounting, general purpose, one input Tachometers which will function with a wide variety of sensors. The instruments display speed plus the run-time of the machinery being monitored.

The two models are electrically similar, but have different size displays and enclosures.

Model	Displays	Bezel size
BA517E	8 digits 9mm high 6 digits 6mm high	96 x 48mm
BA518E	8 digits 18mm high 6 digits 12mm high	144 x 72mm

This abbreviated instruction sheet is intended to assist with installation, a comprehensive instruction manual describing system design and configuration may be downloaded from the BEKA website or may be requested from the BEKA sales office.

2. INSTALLATION

Both models have IP66 front of panel protection but they should be shielded from direct sunlight and severe weather conditions. The rear of both models have IP20 protection.

Cut-out dimensions

Recommended for all installations. Mandatory to achieve IP66 seal between instrument and panel.

BA517E 90 +0.5/-0.0 x 43.5 +0.5/-0.0
BA518E 136 +0.5/-0.0 x 66.2 +0.5/-0.0

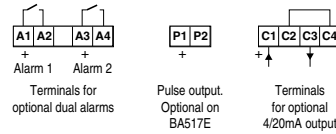
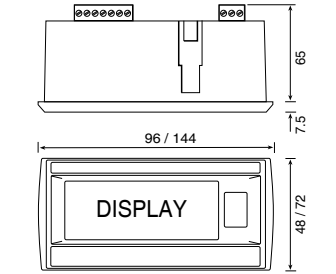

Support panel wiring to prevent vibration damage

Fig 1 Cut-out dimensions and terminals

**Abbreviated instructions for
BA517E and BA518E One input
General purpose Tachometers**

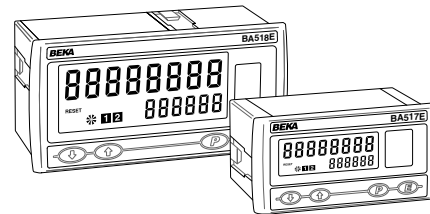

Issue 2
16th September 2016

BEKA associates Ltd. Old Charlton Rd, Hitchin, Hertfordshire, SG5 2DA, UK
Tel: +44(0)1462 438301 Fax: +44(0)1462 453971
e-mail: sales@beka.co.uk web: www.beka.co.uk

The BA517E and BA518E are CE marked to show compliance with the EMC Directive 2014/30/EU.

1. Align foot and body of panel mounting clamp by turning screw anticlockwise

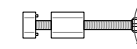

2. Position gasket behind instrument bezel

4. Insert panel clamp into recess and gently pull it onto the dovetail. Engage screw & turn clockwise to tighten the clamp, fit the other clamp(s). Recommended tightening torque 22cNm (1.95lbf.in) Equivalent to finger tight plus one half turn. **DO NOT OVERTIGHTEN**

3. Insert instrument into the panel from the front

BA518E requires 4 clamps for IP66 front panel sealing

Fig 2 Installation procedure

EMC

For specified immunity all wiring should be in screened twisted pairs with screens earthed at one point.

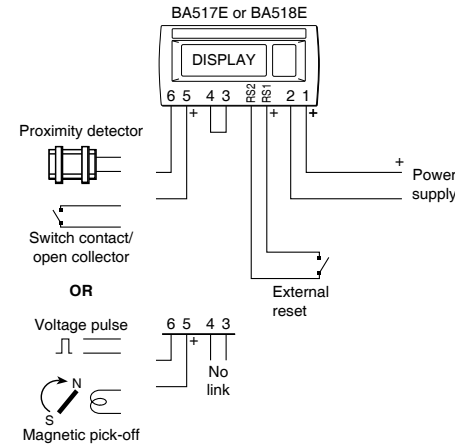

Fig 3 Typical system

Scale card

The Tachometers units of measurement are shown on a printed scale card visible through a window at the right hand side of the display. The scale card is mounted on a flexible strip that is inserted into a slot at the rear of the instrument as shown below

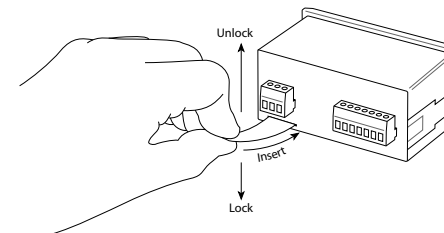

Fig 4 Inserting flexible strip carrying scale card into slot at the rear of Tachometer.

Thus the scale card can easily be changed without removing the Tachometer from the panel or opening the instrument enclosure.

New Tachometers are supplied with a printed scale card showing the requested units of measurement, if this information is not supplied when the instrument is ordered a blank card will be fitted. A pack of self-adhesive scale cards printed with common units of measurement is available as an accessory from BEKA associates. Custom printed scale cards can also be supplied.

To change a scale card, unclip the protruding end of the flexible strip by gently pushing it upwards and pulling it out of the enclosure. Peel the existing scale card from the flexible strip and replace it with a new printed card, which should be aligned as shown below. Do not fit a new scale card on top of an existing card.

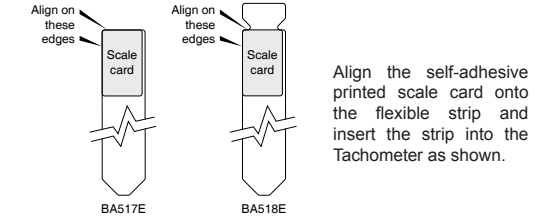
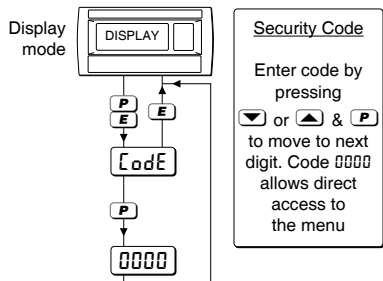

Fig 5 Fitting scale card to flexible strip

3. OPERATION

The Tachometers are controlled by four front panel push buttons. When in operating mode they have the following functions:

- [P] + [E]** Access to configuration menu.
- [V] + [A]** If the Local Run-time reset function $CLr\ t\ o\ t$ in the instrument configuration menu is enabled, operating the **[V]** and **[A]** buttons simultaneously for more than 3 seconds resets the run-time display to zero.
- [E] + [A]** Run-time grand total. If buttons are pressed for ten seconds or longer grand total run-time is reset to zero. This is a configurable function.
- [P] + [V]** Shows in succession, firmware version number, instrument function $f\ R\ E\ o$ and any output accessories that are fitted:
 - **R** Dual Alarm Outputs
 - **P** Pulse output *fitted to all BA518E*
 - **E** 4/20mA output.
- [P] + [A]** When optional alarms are fitted provides direct access to the alarm setpoints if $R\ S\ C\ P$ (access to setpoints) has been enabled in the configuration menu.



4. CONFIGURATION

Tachometers are supplied configured as requested at time of ordering, if not specified default configuration will be supplied but can easily be changed on-site.

Fig 6 shows the location of each function within the configuration menu with a brief summary of the function. Please refer to the full instruction manual for detailed configuration information and for description of the optional outputs.

Access to the configuration menu is obtained by pressing the **P** and **E** buttons simultaneously. If the Tachometer's security code is set to default 0000 the first parameter, **Input** will be displayed. If the instrument is protected by a security code, **CodE** will be displayed. The four digit code must be entered to gain access to the menu.

Unless otherwise specified menu functions are shown on the upper display

When fitted optional alarms, pulse output and 4/20mA output functions appear here.

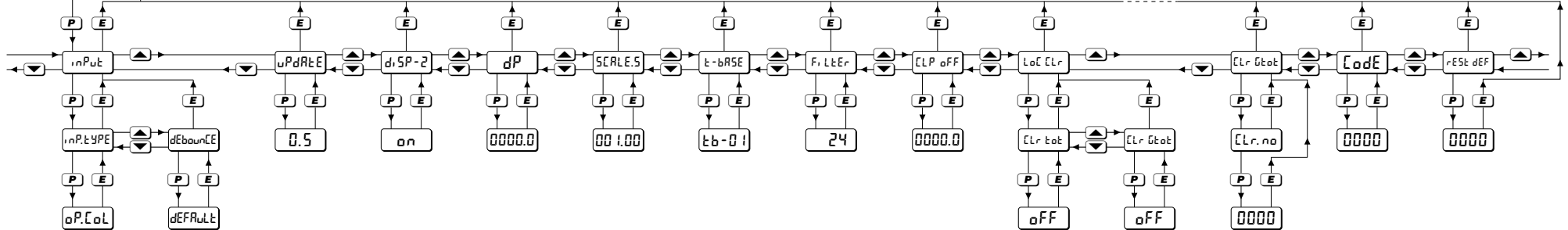

<p>Input</p> <p>▼ or ▲ to select Input type</p> <p>oP.CoL Open Collector</p> <p>UoL.t5.L Pulse <1V >3V</p> <p>UoL.t5.H Pulse <3V >10V</p> <p>Co.L Magnetic pick-off</p> <p>Pr.dEt Proximity detector</p> <p>Co.n.t.R.C.t Switch contact</p>	<p>Debounce</p> <p>▼ or ▲ to select level of debounce.</p> <p>dEbounCE HERUJ L.GHE</p>	<p>Update</p> <p>▼ or ▲ to select interval between display updates, may be set to 0.5, 1, 2, 3, 4 or 5 seconds</p>	<p>Run-time Display</p> <p>▼ or ▲ to turn run-time display on or off</p>	<p>Decimal point</p> <p>▼ or ▲ to select position of decimal point in the speed display</p>	<p>Speed scale factor</p> <p>▼ or ▲ to select value of each digit and P to transfer control to next digit or decimal point</p>	<p>Timebase</p> <p>▼ or ▲ to select speed display timebase</p> <p>tb-01 for speed/sec</p> <p>tb-50 for speed/min</p> <p>tb-3600 for speed/hour</p>	<p>Filter</p> <p>▼ or ▲ to adjust value of each digit and P to transfer control to other digit</p> <p>First digit: filter magnitude</p> <p>second digit: step response</p> <p>Note: While making adjustments the filtered rate display is shown on lower display so stability can be assured</p>	<p>Clip off</p> <p>Tachometer display below which run-time timer is inhibited</p> <p>▼ or ▲ to adjust value and P to move to next digit</p>	<p>Local run-time reset</p> <p>▼ or ▲ to turn the local run-time reset function on or off. When on, run-time display is reset to zero when ▼ and ▲ are operated simultaneously in display mode for more than 3 seconds</p>	<p>Local run-time grand total reset</p> <p>▼ or ▲ to turn the local grand total run-time reset function on or off. When on, grand total run-time may be reset to zero when E and ▲ are operated simultaneously in display mode for more than 10 seconds</p>	<p>Reset run-time grand total</p> <p>Press ▼ or ▲ to select 9E5 to reset grand total to zero</p> <p>Confirm instruction by entering 5ur.E. Press ▼ or ▲ to adjust each digit and P to move to next digit</p>	<p>Define Security Code</p> <p>Enter by pressing ▼ or ▲ and P to move to next digit</p>	<p>Reset configuration to factory defaults</p> <p>Confirm instruction by entering 5ur.E. Press ▼ or ▲ to adjust each digit and P to move to next digit</p>
--	---	---	---	--	--	---	---	---	---	---	--	---	--



Manuals, certificates and data-sheets can be downloaded from http://www.beka.co.uk/ba517_8e

Fig 6 Configuration menu