

1. DESCRIPTION

The BA304NE and BA324NE are field mounting, Ex nA and Ex tc certified digital indicators that display the current flowing in a 4/20mA loop in engineering units. They are loop powered but only introduce a 1.2V drop into the loop.

The two models are electrically similar, but have different size displays.

Model	Display
BA304NE	4 digits 34mm high
BA324NE	5 digits 29mm high and 31 segment bargraph.

This abbreviated instruction sheet is intended to assist with installation and commissioning, a comprehensive instruction manual describing safety certification, system design and calibration is available from the BEKA sales office or may be downloaded from our website.

Both models have ATEX and IECEx certification permitting installation in Zone 2 flammable gas and Zone 22 combustible dust atmospheres without the need for Zener barriers or galvanic isolators. The certification label, which is located on the top of the instrument enclosure, shows the certificate numbers and the certification codes. Copies of certificates may be downloaded from our website.

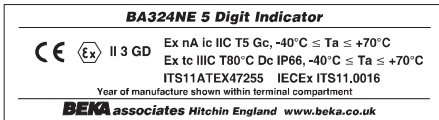

All models have gas and dust certification.

2. INSTALLATION

The BA304NE and BA324NE indicators have robust IP66 glass reinforced polyester (GRP) enclosures incorporating an armoured glass window and stainless steel fittings. They are suitable for exterior mounting in industrial Zone 2 or Zone 22 environments.

The BA304NE & BA324NE are CE marked to show compliance with the European Explosive Atmospheres Directive 94/9/EC and the European EMC Directive 2004/108/EC

They are surface mounting, but may be pipe mounted using an accessory kits.

Fig 1 shows the installation procedure.

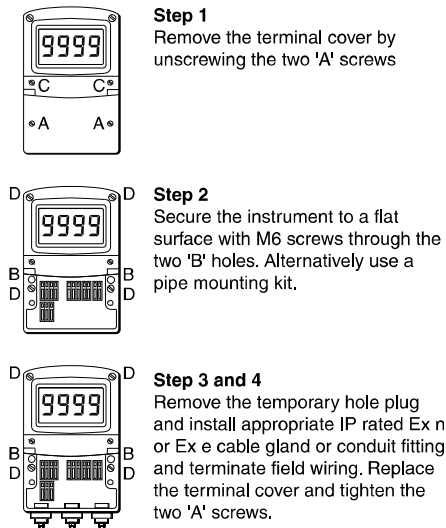
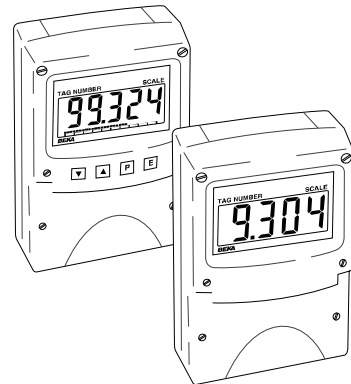

Fig 1 Installation procedure

Abbreviated Instruction for BA304NE and BA324NE Ex nA and Ex tc field mounting loop powered indicators



Issue 2
10th March 2014

BEKA associates Ltd. Old Charlton Rd, Hitchin, Hertfordshire, SG5 2DA, UK Tel: +44(0)1462 438301 Fax: +44(0)1462 453971 e-mail: sales@beka.co.uk web: www.beka.co.uk

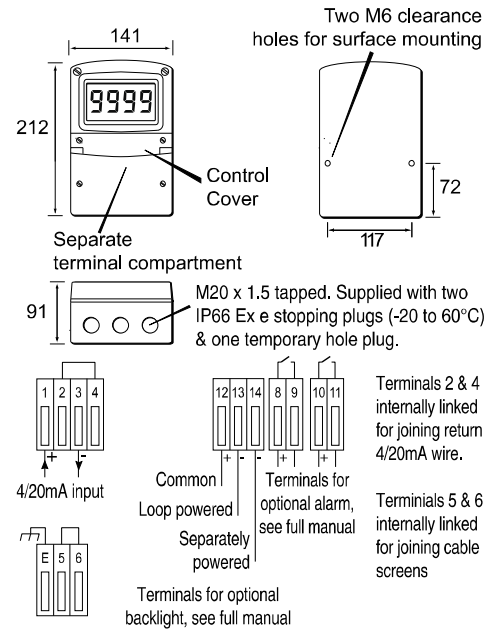

Fig 2 Dimensions and terminal connections

The indicator's earth terminal is connected to the carbon loaded GRP enclosure. If this enclosure is not bolted to an earthed post or structure, the earth terminal should be connected to the plant potential equalising conductor.

A bonding plate is provided to ensure electrical continuity between the three conduit / cable entries.

Terminals 8, 9, 10 & 11 are only fitted when the indicator includes optional alarms. See full manual for details.

Terminals 12, 13 & 14 are only fitted when the indicator includes an optional backlight. See full manual for details.

EMC

For specified immunity all wiring should be in screened twisted pairs, with the screens earthed in the safe area.

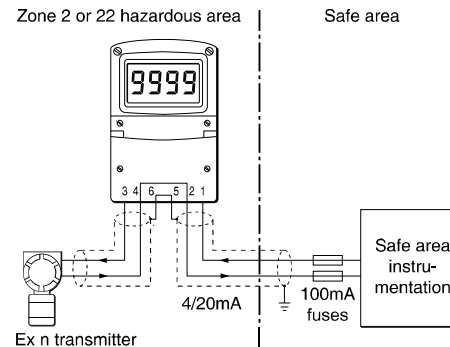

Fig 3 Typical measurement loop

Units of measurement & tag number

Both indicators have an escutcheon around the liquid crystal display which can be printed with any units of measurement and tag information specified when the indicator was ordered. If no information is supplied a blank escutcheon will be fitted but legends may be added on-site via an embossed strip, dry transfer or a permanent marker. Printed escutcheons are available from BEKA as an accessory which should be fitted on top of the blank escutcheon. Do not remove the blank escutcheon.

To gain access to the escutcheon remove the terminal cover by unscrewing the two 'A' screws which will reveal two concealed 'D' screws. If the instrument is fitted with an external keypad, also unscrew the two 'C' screws securing the keypad and unplug the five way connector. Finally unscrew all four 'D' screws and carefully lift off the front of the instrument.

3. OPERATION

The indicators are controlled and configured via four push buttons located behind the instrument control cover, or via an optional keypad on the outside of the control cover. In the display mode i.e. when the indicator is displaying a process variable, these push buttons have the following functions:

- P** While this button is pushed the indicator will display the input current in mA, or as a percentage of the instrument span depending upon how the indicator has been conditioned. When the button is released the normal display in engineering units will return. The function of this push button is modified when optional alarms are fitted to the indicator.
- ▼** While this button is pushed the indicator will display the numerical value and analogue bargraph* the indicator has been calibrated to display with 4mA input. When released the normal display in engineering units will return.
- ▲** While this button is pushed the indicator will display the numerical value and analogue bargraph* the indicator has been calibrated to display with 20mA input. When released the normal display in engineering units will return.
- E** No function in the display mode unless the tare function is being used.
- P + ▼** Indicator displays firmware number followed by version.
- P + ▲** When optional alarms are fitted provides direct access to the alarm setpoints if the 'ACSP' access setpoints in display mode function has been enabled.
- P + E** Provides access to the configuration menu via optional security code.

* Only the BA324NE has a bargraph

4. CONFIGURATION

Indicators are supplied calibrated as requested when ordered, if not specified default configuration will be supplied but can easily be changed on-site.

Fig 4 shows the location of each function within the configuration menu with a brief summary of the function. Please refer to the full instruction manual for detailed configuration information and for a description of the lineariser and the optional dual alarms.

Access to the configuration menu is obtained by pressing the **P** and **E** buttons simultaneously. If the indicator security code is set to the default '0000' the first parameter 'FunC' will be displayed. If the indicator is protected by a security code, 'CodE' will be displayed and the code must be entered to obtain access to the menu.

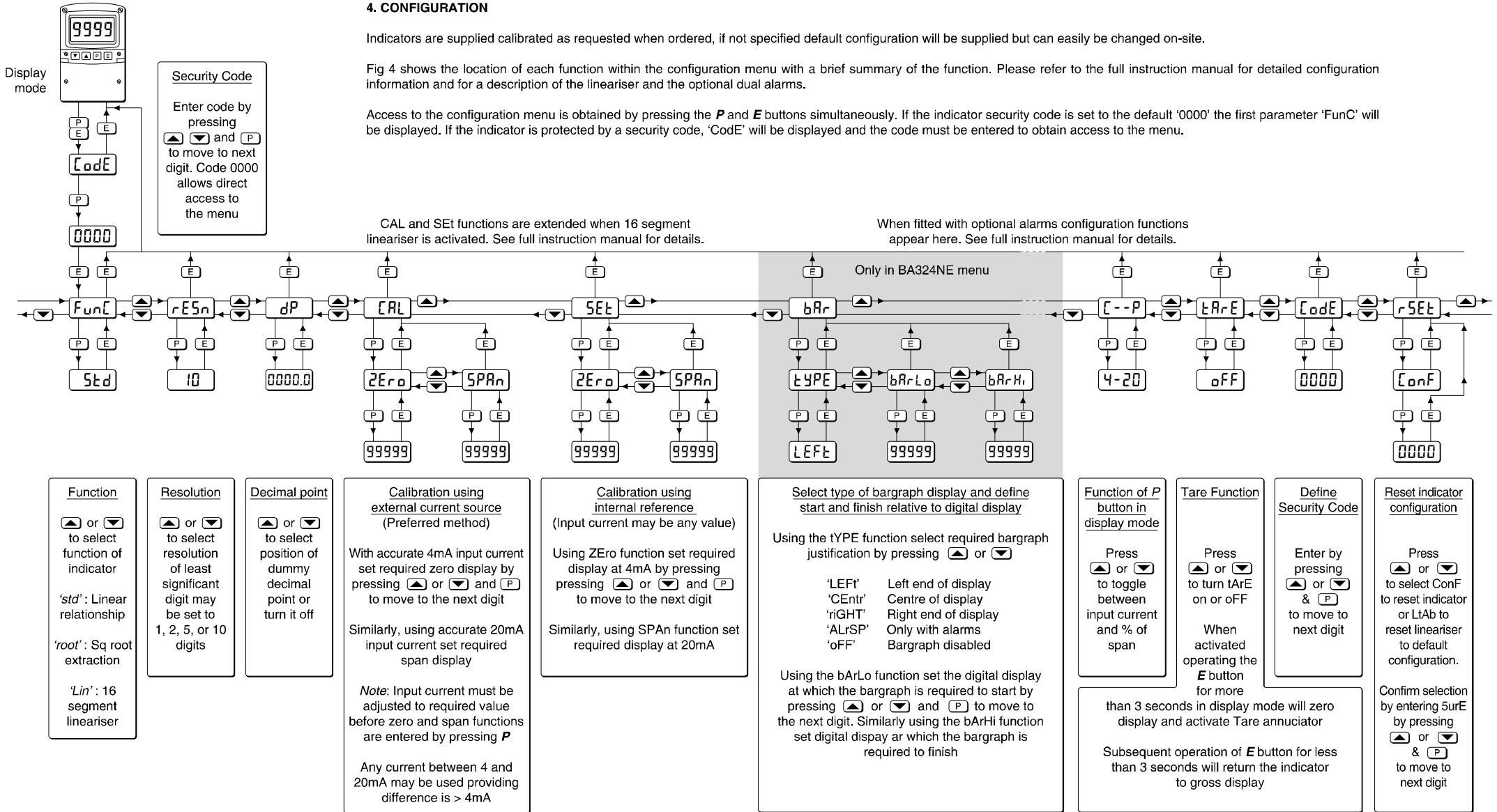

Manuals, certificates and data-sheets can be downloaded from <http://www.beka.co.uk/lpi3/>

Fig 4 Configuration menu

BEKA associates

Old Charlton Rd, Hitchin, Hertfordshire, SG5 2DA, UK
 Tel: +44(0)1462 438301 Fax: +44(0)1462 453971
 e-mail: sales@beka.co.uk web: www.beka.co.uk