

**BA524D**  
**loop-powered**  
**4½ digit field**  
**mounting indicator**

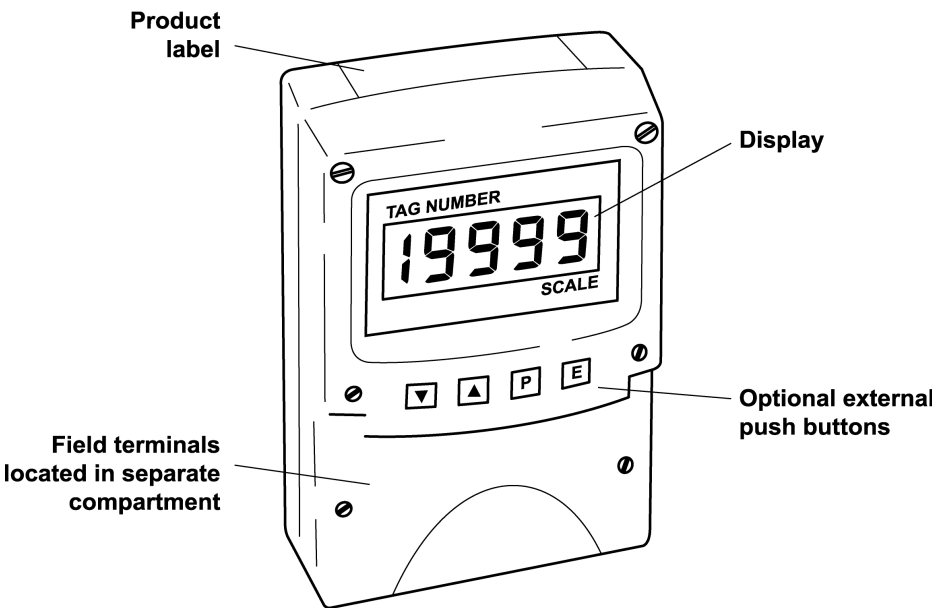

## CONTENTS

- 1. Description**
- 2. Operation**
  - 2.1 Controls
- 3. Applications**
  - 3.1 Transmitter loops
  - 3.2 Remote indication
- 4. Installation**
  - 4.1 Location
  - 4.2 Installation procedure
  - 4.3 EMC
- 5. Programming and Calibration**
  - 5.1 Summary of programmable functions
  - 5.2 Root extractor
  - 5.3 Resolution
  - 5.4 Position of decimal point
  - 5.5 Calibration using an external current source.
  - 5.6 Calibration using internal references
  - 5.7 Conditioning sub-menu
    - 5.7.1 AC rejection
    - 5.7.2 Calibration of internal references.
  - 5.8 Function of the *P* push-button
  - 5.9 Security code
  - 5.10 Over and under-range
- 6. Calibration Examples**
  - 6.1 Using an external current source
  - 6.2 Using the internal references
- 7. Maintenance**
  - 7.1 Fault finding during commissioning
  - 7.2 Fault finding after commissioning
  - 7.3 Servicing
  - 7.4 Routine maintenance
  - 7.5 Guarantee
  - 7.6 Customer comments
- 8. Accessories**
  - 8.1 Units of measurement and instrument identification.
  - 8.2 Alarms
    - 8.2.1 Solid state output
    - 8.2.2 Programming and adjustment
    - 8.2.3 Alarm enable
    - 8.2.4 Setpoint adjustment
    - 8.2.5 Alarm function
    - 8.2.6 Alarm output status
    - 8.2.7 Hysteresis
    - 8.2.8 Alarm delay
    - 8.2.9 Alarm silence time
    - 8.2.10 Access setpoint
    - 8.2.11 Adjusting alarm setpoints from display mode.
  - 8.3 Lineariser
    - 8.3.1 Calibration using an external current source.
    - 8.3.2 Calibration using internal references.
  - 8.4 Tare function
  - 8.5 Display backlight
  - 8.6 External switches
  - 8.7 Pipe mounting kits
  - 8.8 Stem mounting kit

**1. DESCRIPTION**

The BA524D is a 4½ digit loop powered digital indicator which displays the current flowing in a 4/20mA loop in engineering units. The indicator only introduces a 1.1V drop which allows it to be installed into almost any 4/20mA current loop. No additional power supply or battery is required.

The BA524D is a third generation instrument which, although having additional features including a separate terminal compartment, remains electrically compatible with the original BA524 and BA524C.

The main application of the BA524D is to display a measured variable or control signal in a process area. The zero and span of the display are independently adjustable so that the indicator can be calibrated to display any variable represented by the 4/20mA current, e.g. temperature, flow, pressure or level.

The instrument is housed in a robust IP66 glass reinforced polyester (GRP) enclosure with an armoured glass window.

**2. OPERATION**

Fig 1 shows a simplified block diagram of a BA524D. The 4/20mA input current flows through resistor R1 and forward biased diode D1. The voltage developed across D1, which is relatively constant, is multiplied by a switch mode power supply and used to power the instrument. The voltage developed across R1, which is proportional to the 4/20mA input current, provides the input signal for the analogue to digital converter.

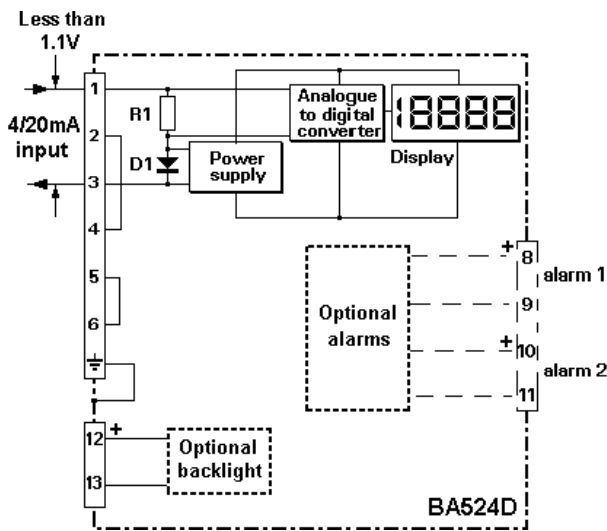

Fig 1 Simplified block diagram of BA524D

Each time a 4/20mA current is applied to the instrument, initialisation is performed. After a short delay the following display sequence occurs:

- 1.8.8.8.8 Display test in which all segments of the display are activated for 0.5 seconds.
- Blank display For 0.5 seconds.
- Decimal points For 3 seconds. cycled
- Input current Using calibration information stored in engineering instrument memory. units.

**2.1 Controls**

The BA524D is controlled and calibrated via four push-button switches which are located behind the instrument control cover, or as an option on the instrument cover. In the display mode i.e. when displaying a variable, these switches have the following functions:

- P** While this button is pushed the indicator will display the input current in mA, or as a percentage of the instrument span depending upon how the indicator has been programmed. When the button is released the normal display in engineering units will return. The function of this push-button is modified when alarms or a tare function are fitted to the indicator.
- Down** While this button is pushed the indicator will display the number which the indicator has been calibrated to display with a 4mA input. When released the normal display in engineering units will return.
- Up** While this button is pushed the indicator will display the number which the indicator has been calibrated to display with a 20mA input. When released the normal display in engineering units will return.
- E** No function in the display mode.

### 3. APPLICATIONS

#### 3.1 Transmitter loops

The BA524D indicator may be connected in series with any 4/20mA current loop that can tolerate the 1.1V drop required to operate the instrument, and be calibrated to display the measured variable or control signal in engineering units.

Fig 2 illustrates a typical application in which a BA524D indicator is connected in series with a 2-wire transmitter.

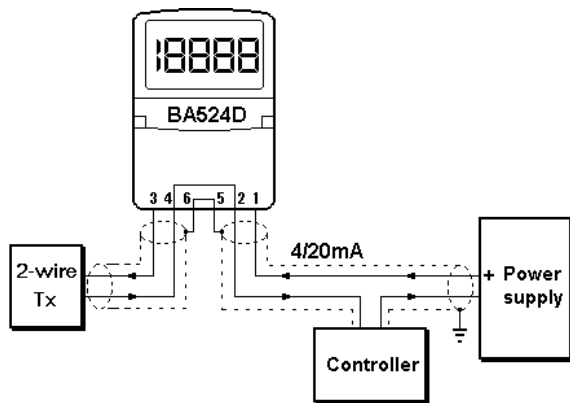

Fig 2 BA524D in a transmitter loop

Considering the example shown in Fig 2, the sum of the maximum voltage drops of all the components in the loop must be less than the minimum power supply voltage.

Minimum operating voltage of 2-wire Tx	10.0
Maximum voltage drop caused by controller	5.0
Maximum voltage drop caused by BA524D	1.1
Maximum voltage drop caused by cables	0.4
	16.5V

Therefore at 20mA the power supply in this example must have an output greater than 16.5V

#### 3.2 Remote indication

A BA524D indicator may be driven from any 4/20mA signal to provide remote indication. Fig 3 shows a typical application in which the output from a gas analyser drives a BA524D. Again it is necessary to ensure that the voltage capability of the 4/20mA gas analyser output is greater than the sum of voltage drops introduced by the BA524D and the cable resistance.

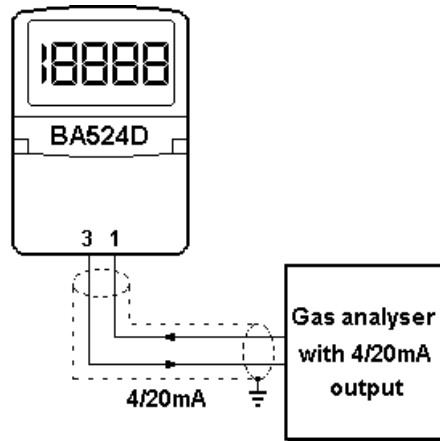

Fig 3 Remote indication

### 4. INSTALLATION

#### 4.1 Location

The BA524D indicator is housed in a robust IP66 glass reinforced polyester (GRP) enclosure incorporating an armoured glass window and stainless steel fittings making it suitable for exterior mounting in most industrial installations, including off-shore and waste water treatment.

The BA524D is surface mounting, but may be pipe or stem mounted using the accessory kits described in sections 8.7 and 8.8 of this manual.

The field terminals and the two mounting holes are located in a separate compartment with a sealed cover allowing the instrument to be installed without exposing the display assembly. Terminals 2 and 4 are internally joined and may be used for linking the return 4/20mA wire - see Fig 2. Similarly terminals 5 and 6 are internally joined and may be used for linking cable screens. The BA524D earth terminal is connected to the internal EMC filters. For maximum radio frequency interference rejection this terminal should be connected to a local earth, or to an earthed cable screen. To prevent circulating currents, cable screens should only be earthed at one point.

The BA524D enclosure is fitted with a bonding plate to ensure electrical continuity between the three conduit / cable entries.

**4.2 Installation Procedure**

Fig 4 illustrates the instrument installation procedure.

- a. Remove the instrument terminal cover by unscrewing the two captive 'A' screws.
- b. Mount the instrument on a flat surface and secure with screws or bolts through the two 'B' holes. Alternatively use one of the pipe or stem mounting kits described in sections 8.7 and 8.8
- c. Remove the temporary dust seals from the three cable entries and install the required glands, conduit fittings or blanking plugs.  
Note: the temporary dust seals do not provide IP66 protection.
- d. Connect the field wiring to the terminals as shown in Fig 5.
- e. Replace the instrument terminal cover and evenly tighten the two 'A' screws.

**4.3 EMC**

The BA524D complies with the requirements of the European EMC Directive 89/336/EEC. For specified immunity all wiring should be in screened twisted pairs.

Additional immunity may be obtained by connecting the BA524D earth terminal to a local earth, or to an earthed cable screen.

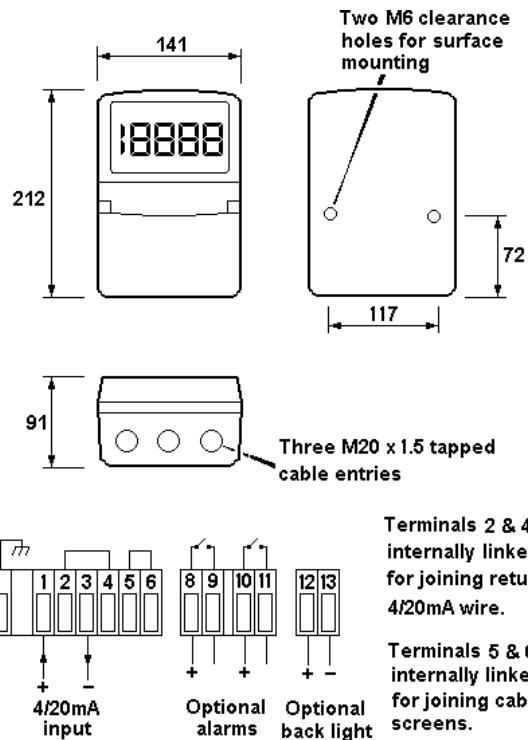
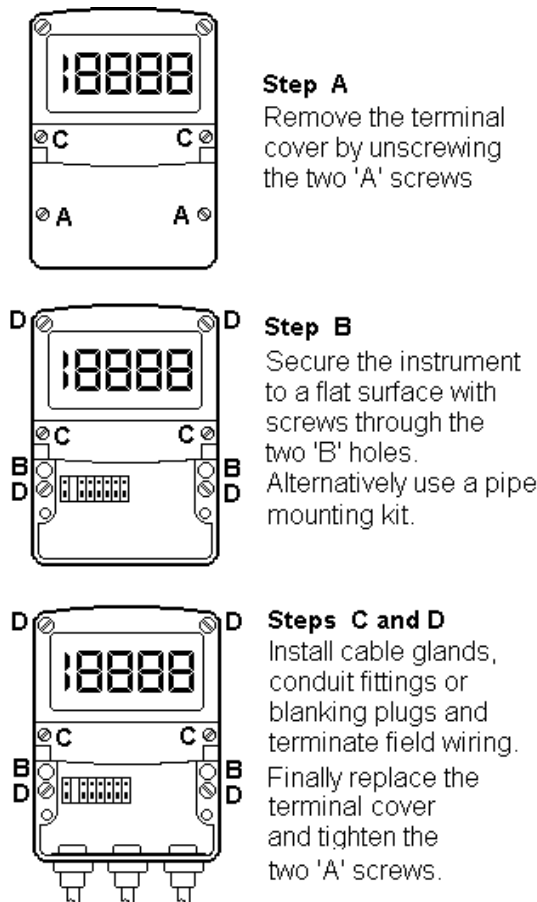

Fig 5 Dimensions and terminal connections

Fig 4 BA524D installation procedure

## 5. PROGRAMMING & CALIBRATION

The BA524D is programmed and calibrated via four push-buttons which are located behind the instrument control cover. When frequent access to the push-buttons is required, the indicator can be supplied with external membrane push-buttons mounted on the outside of the control cover.

All the programming functions are contained in an easy to use menu which is shown diagrammatically in Fig 6. Each function is summarised in section 5.1 which includes references to more detailed information. Although this simple menu driven system enables most adjustments to be made without repeated reference to this manual, we recommend that at least the summary of the programmable functions in section 5.1 is read before attempting programming or recalibration.

When the indicator is fitted with alarms, linearisation or a tare function, the basic menu is expanded to include functions associated with these optional features. All the optional functions are described in section 8 of this manual.

Throughout this manual push-buttons are shown in italics e.g. *P* or *Up* push-button, and legends displayed by the indicator are shown within inverted commas e.g. 'CAL' and 'ALr2'.

Access to the programme menu is obtained by operating the *P* and *E* push-buttons simultaneously. If the instrument is not protected by a security code the first parameter 'root' will be displayed. If a security code other than the default code 0000 has already been entered, the indicator will display 'COdE'. Press *P* to clear this prompt and enter the security code for the instrument using the *Up*, *Down* and *P* push-buttons. If the correct code has been entered pressing *E* will cause the first parameter 'root' to be displayed. If an incorrect code is entered the indicator will return to the display mode.

Once within the menu the required parameter can be reached by scrolling through the main menu using the *Up* and *Down* push-buttons as shown in Fig 6. When returning to the display mode following recalibration or changes to any parameters, the indicator will display circulating decimal points for a few seconds while the new information is stored in permanent memory.

All new BA524D indicators are supplied calibrated as requested at the time of ordering. If calibration is not requested, the indicator will be set to display 0.00 with 4mA input, and 100.00 with 20mA input, but can easily be re-calibrated on-site.

### 5.1 Summary of programmable functions

This section summarises all of the programmable functions and when read in conjunction with Fig 6 provides sufficient information to condition and calibrate the indicator. A cross-reference to more detailed information is given for each function.

Display	Description of function
'root'	<b>Square root extractor</b> Turns the square root extractor for linearising the output from differential flowmeters 'on' or 'off'. This function is omitted when a lineariser is installed. See section 5.2
'rESn'	<b>Display resolution</b> Selects the resolution of the least significant display digit. May be set to 1, 2, 5 or 10 digits. See section 5.3
'd.P.'	<b>Decimal point</b> Positions the dummy decimal point between any of the digits or turns it off. See section 5.4
'CAL'	<b>Calibration of display using external current source.</b> Enables the zero and span of the indicator to be adjusted using an external current source such as a calibrator. Also enables a complete loop to be calibrated from primary element to the indicator display. When used with an accurate traceable current source this is the preferred method of calibration. See section 5.5

Display	Description of function	Display	Description of function
'SEt'	<p><b>Calibration of display using internal references.</b> Enables the zero and span of the indicator to be adjusted without the need for an accurate input current or disconnection from the 4/20mA loop. See section 5.6</p>	'C -- P'	<p><b>Function of P push-button</b> The BA524D may be programmed to display the input current in milliamps or as a percentage when the P push-button is operated. See section 5.8</p>
'Cond'	<p><b>Indicator conditioning</b> This function provides access to a sub-menu enabling the mains (line) frequency to be selected and the internal references to be calibrated. Because these parameters will alter the indicator display, they are contained in a sub-menu to prevent inadvertent adjustment.</p> <p style="text-align: center;"><b>Caution</b> <b>If the mains filter frequency is changed, the indicator display and internal references (if used) must be recalibrated.</b></p> <p>See section 5.7</p>	'COdE'	<p><b>Security code</b> Defines a four digit numeric code which must be entered to gain access to programmable functions. Default code 0000 disables the security function and allows unrestricted access to all programmable functions. See section 5.9</p>
'FrE'	<p><b>Frequency rejection</b> Defines the mains (line) frequency at which the indicator has maximum ac rejection. 50 or 60Hz may be selected. This function must be set before the instrument is calibrated as it affects the indicator display. See section 5.7.1</p>		
'rEF'	<p><b>Calibration of internal references</b> The instrument contains two references representing a 4 and 20mA input. These enable the BA524D display to be calibrated without the need for an external calibrator, or disconnection from the 4/20mA supply. See SEt function. If the SEt or C--P functions are to be used, the internal references should be periodically calibrated. See section 5.7.2</p>		

### 5.2 Root extractor: **root**

This function is primarily intended for use with differential flowmeters which have a square law 4/20mA output. To activate the square root extractor select 'root' from the menu and press *P* which will reveal if the function is 'On' or 'OFF'. If the function is set as required, press *E* to return to the menu, or press the *Up* or *Down* button to change the setting, followed by the *E* button to return to the main menu.

For reference, the following table shows the output current from a non-linearised differential flowmeter.

% of full flow	Current output mA
2.5	4.01
10.0	4.16
25.0	5.00
50.0	8.00
75.0	13.00
100.0	20.00

### 5.3 Resolution: **rESn**

This function defines the resolution of the least significant display digit. Decreasing the display resolution can improve the readability of a noisy signal. Select 'rESn' from the menu and press *P* which will reveal the current display resolution. To change the resolution press the *Up* or *Down* button to select 1, 2, 5 or 10 digits, followed by the *E* button to return to the menu.

### 5.4 Position of the decimal point: **d.P.**

A dummy decimal point can be positioned between any of the digits or may be absent. To position the decimal point select 'd.P.' from the menu and press *P*. The decimal point can then be moved or turned off by pressing the *Up* or *Down* push-button, followed by *E* to return to the menu.

### 5.5 Calibration of display using an external current source: **CAL**

This function enables the zero and span of the indicator to be adjusted using an external calibrated current source. When used with an accurate traceable current source this is the preferred method of calibration.

To calibrate the indicator select 'CAL' from the main menu and press *P*. The indicator will display 'ZErO' which is a request for a 4mA input current. Adjust the external current calibrator to 4.000mA and again press *P* which will reveal the current zero display. Each digit of the indicator display can be changed by pressing the *Up* or *Down* buttons. When the first digit is correct,

pressing *P* will transfer control to the next digit. When all the digits have been adjusted, press *E* to enter the new zero. The indicator will display 'Ent' for a few seconds while the information is being stored in memory, and will then return to the 'ZErO' prompt.

To adjust the display at 20mA, press the *Up* button which will cause the indicator to display 'SPAN'. Adjust the external current calibrator to 20.000mA and again press *P* which will reveal the existing full scale display. Each digit of the indicator display can be changed by pressing the *Up* or *Down* buttons. When the first digit is correct, pressing *P* will transfer control to the next digit. When all the digits have been adjusted press *E* to enter the new span. The indicator will display 'Ent' for a few seconds while the information is being stored in memory, and will then return to the 'SPAN' prompt. Finally press *E* again to return to the main menu.

This function may also be used when calibrating a complete loop from primary element to indicator display e.g. when the indicator is displaying the output from a resistance thermometer transmitter.

### 5.6 Calibration using internal references: **SEt**

This function enables the zero and span of the indicator to be adjusted without the need for an accurate external current source, or for disconnection from the 4/20mA loop. The accuracy of this method depends upon the accuracy of the internal references which should be regularly calibrated as described in section 5.7.2

To calibrate the indicator select 'SEt' from the main menu and press *P*. The indicator will display 'ZErO'; pressing *P* again will reveal the current display at 4mA. Each digit of the indicator display can be changed by pressing the *Up* or *Down* buttons. When the first digit is correct pressing *P* will transfer control to the next digit. When the least significant digit has been adjusted, press *E* to return to the 'ZErO' prompt which completes the adjustment.

To adjust the display at 20mA, press the *Up* button which will cause the indicator to display 'SPAN'. pressing *P* again will reveal the indicator display. Each digit can be changed by pressing the *Up* or *Down* buttons. When the first digit is correct, pressing *P* will transfer control to the next digit. When the least significant digit has been adjusted press *E* to return to the 'SPAN' prompt followed by *E* to return to the menu.



### 5.7 Conditioning sub-menu: Cond

This sub-menu allows the mains (line) frequency at which the indicator has maximum ac rejection to be selected and the two internal references to be calibrated. These functions are contained in a sub-menu to minimise the possibility of inadvertent adjustment. To gain access to the sub-menu select 'Cond' from the main menu and press *P*. The indicator will display 'SurE' to warn that changing the parameters in the sub-menu will change the indicator display. Pressing *P* again will give access to the sub-menu, or pressing *E* will return the indicator to the main menu.

#### 5.7.1 AC rejection: FrE

##### Caution

**If the mains filter frequency is changed, the indicator display and internal references (if used) must be recalibrated.**

To provide maximum low frequency rejection the internal digital filter may be set to operate at 50 or 60Hz to correspond with the local mains (line) frequency. To change the frequency select 'FrE' from the 'Cond' sub-menu and press *P* which will reveal the current setting. The setting can be changed by pressing the *Up* or *Down* buttons followed by the *E* button to return to the sub-menu.

#### 5.7.2 Calibration of internal references: rEF

The indicator contains two references representing 4 and 20mA. These references are used in the 'SEt' function which enables the indicator display to be calibrated without an external current calibrator. They are also used in the 'C--P' function when the *P* push-button is programmed to display the input current in the display mode. If neither of these functions is to be used, it is not necessary to calibrate the internal references.

To calibrate the references select 'rEF' from the sub-menu and press *P* which will result in a '0.004A' prompt being displayed. Adjust the external current calibrator to 4.000mA and again press *P*. The indicator will display 'Ent' when the 4mA reference has been updated and will then return to the '.004A' prompt.

To re-calibrate the 20mA internal reference, press the *Up* button which will cause the indicator to display '.020A'. Adjust the external current calibrator to 20.000mA and again press *P*. The indicator will display 'Ent' when the 20mA reference has been updated and will then return to the '.020A' prompt. Two operations of the *E* button will return the indicator to the main menu.

The accuracy of the internal references, and hence the display accuracy when using the SEt function, will depend upon the accuracy of the external current source. With a maximum span of 19999 the indicators have a display resolution of 0.8 $\mu$ A, we therefore recommend that the accuracy of the external current source used for calibration is greater than 0.4 $\mu$ A.

### 5.8 Function of the *P* push-button: C - - P

This parameter defines the function of the *P* push-button when the indicator is in the display mode. While the button is operated the indicator will display the input current in milliamps or as a percentage of the span.

To check or change the parameter select 'C - -P' from the main menu and press *P* to reveal the current setting. Pressing the *Up* or *Down* button will toggle the setting between '4-20' the current display and 'PC' the percentage display. When set as required press *E* to return to the main menu.

Accuracy of the current display depends upon the accuracy of the internal references which should be periodically calibrated - see section 5.7.2

### 5.9 Security code: COdE

The calibration and conditioning of the instrument may be protected by a four digit security code which must be entered before access to the programme menu is granted. New instruments are programmed with the default security code 0000 which allows unrestricted access to all programming functions.

To enter a new security code select 'COdE' from the menu and press *P* which will cause the indicator to display the current security code. Each digit of the code can be changed using the *Up* and *Down* push-buttons, and the *P* button to move to the next digit. When the required code has been entered press *E* to return to the main menu. The revised security code will be activated when the indicator is returned to the operating mode.

If the security code is lost, access to the programmable functions can be obtained by moving the internal security link to the override position. The security code can then be viewed by selecting 'CodE' from the main menu and pressing *P*.

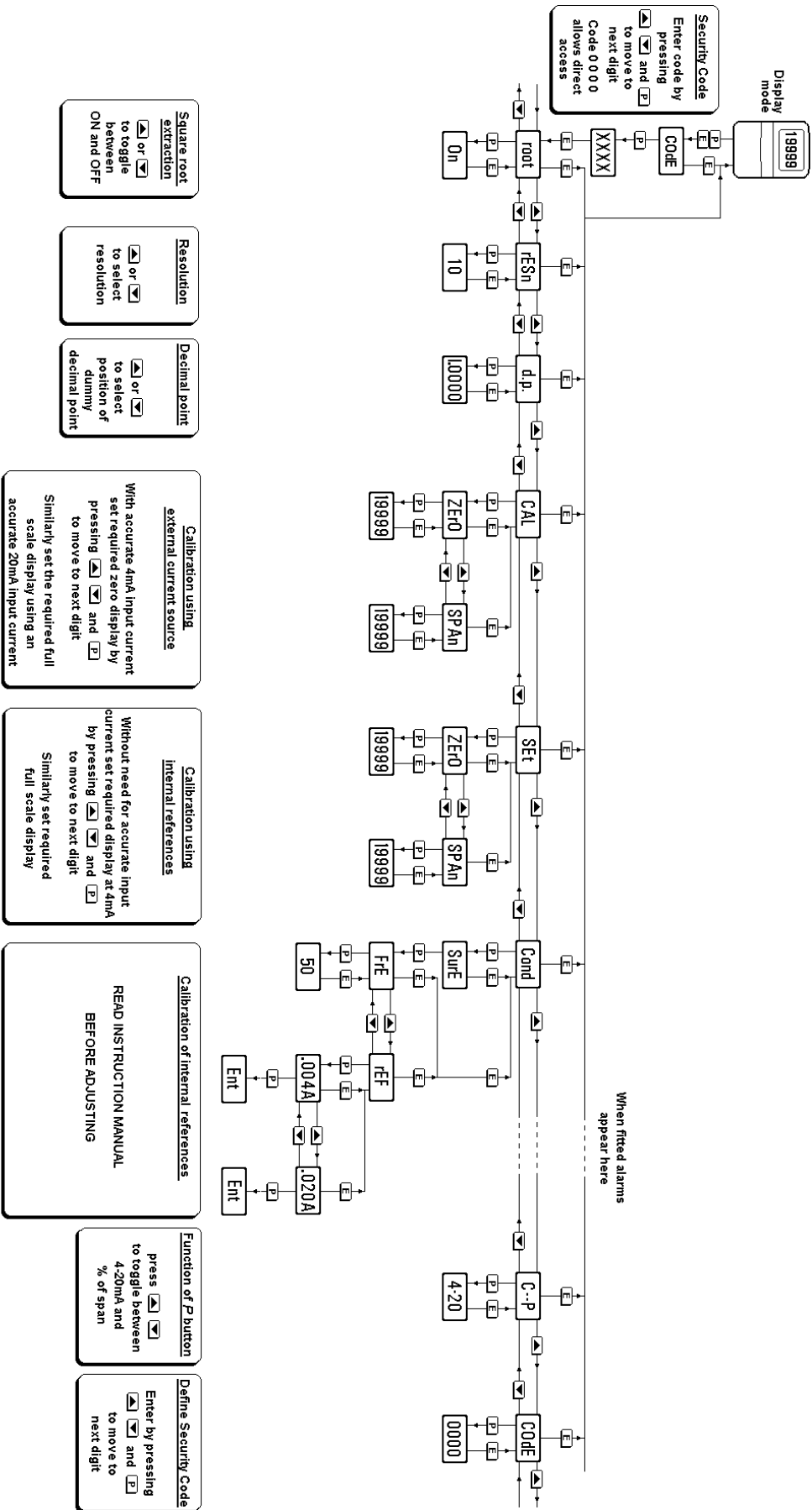
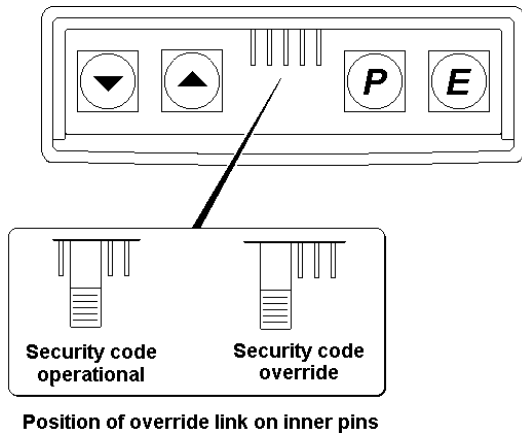

Fig 6 Programme Structure

To gain access to the security code link, remove the instrument control cover, and if fitted unplug the external switch connector. The security code override link is located on the inner row of five pins as shown in Fig 7.



Position of override link on inner pins

Fig 7 Location of security code override link

### 5.10 Over and under-range

If the indicator display range is exceeded, the four least significant digits will be blanked. Under-range is indicated by '-1' and over-range by '1'. Under and over-range are also indicated if the input current falls below approximately 3.5mA or rises above approximately 21mA.

If the input current falls below 3mA the instrument initialisation sequence is performed as described in section 2.

## 6. CALIBRATION EXAMPLES

The following examples illustrate the two ways in which a BA524D indicator may be calibrated.

### 6.1 Using an external current source

The BA524D indicator is required to display:

-50.0	with a 4mA input
1050.0	with a 20mA input

from a linear transducer. Maximum display resolution is required, the frequency of the mains supply is 50Hz and the existing security code is 1209. In the operating mode the indicator is required to display the input current as a percentage of span when the *P* push-button is operated.

#### Step 1 Connect indicator to calibrator

Connect the indicator to an accurate external current source. Terminal 1 positive. The indicator will automatically perform the initialisation routine described in section 2, and then display the input current using the existing calibration information.

#### Step 2 Enter programming mode

With an input current between 4 and 20mA put the indicator in the programming mode by simultaneously pressing *P* and *E*. The indicator will respond by displaying 'COdE'. Press *P* to clear this prompt and set the display to the security code 1209 using the *Up*, *Down* and *P* push-buttons. Pressing *E* will enter the code, and after a few seconds during which the decimal points will be scrolled, the first parameter 'root' in the main menu will be displayed.

#### Step 3 Square root extraction

With 'root' displayed, press *P* which will reveal the root extractor status. The root extractor can be turned on or off by the *Up* or *Down* buttons. Select 'OFF', and press *E* to return to the main menu.

#### Step 4 Select frequency of max rejection

Scroll through the main menu until 'Cond' is displayed. Enter the sub-menu by pressing *P* twice and select the 'FrE' function. Using the *Up* or *Down* buttons select '50', and then press *E* twice to return to the main menu.

**Step 5 Define function of P push-button**

Select 'C--P' from the main menu and press *P* to reveal the function of the *P* button in the display mode. Select percentage 'PC' and return to the main menu by pressing *E*

Note: Because an input current display in milliamps is not required, it is not necessary to calibrate the two internal references.

**Step 6 Position dummy decimal point**

Scroll through the main menu until 'd.P.' is displayed and then press *P*. Using the *Up* and *Down* push-buttons position the dummy decimal point in front of the least significant digit.

Press *E* to return to the main menu.

**Step 7 Calibrate the display**

Scroll through the main menu until 'CAL' is displayed. Press *P* and the indicator will request a 4mA input by displaying 'ZEro'. Set the input current to  $4.0000 \pm 0.0004\text{mA}$  and press *P* again which will reveal the existing zero display. Using the *Up*, *Down* and *P* push-buttons enter the required zero display of -50.0 Press *E* to return to the 'ZEro' prompt.

Press the *Up* push-button and the indicator will request a 20mA input by displaying 'SPAn'. Set the input current to  $20.0000 \pm 0.0004\text{mA}$  and again press *P* which will reveal the existing display at 20mA. Using the *Up*, *Down* and *P* push-buttons enter the required display of 1050.0

Press *E* twice to return to the main menu.

**Step 8 Return to the display mode**

Following completion of calibration return to the display mode by pressing '*E*'.

**6.2 Using the internal references**

As in 7.1 the BA524D is required to display:

-50.0	with a 4mA input
1050.0	with a 20mA input

from a linear transducer. Maximum display resolution is required, the frequency of the mains supply is 50Hz and the existing security code is 1209. In the operating mode the indicator is required to display the input current in milliamps when the *P* push-button is operated.

This example assumes that the internal references have been routinely calibrated.

**Step1 Enter the programming mode**

With an input current between 4 and 20mA put the indicator in the programming mode by simultaneously pressing *P* and *E*. The indicator will respond by displaying 'COdE'. Press *P* to clear this prompt and set the display to the security code 1209 using the *Up*, *Down* and *P* push-buttons. Pressing *E* will enter the code, and after a few seconds during which the decimal points will be scrolled, the first parameter 'root' in the main menu will be displayed.

**Step 2 Square root extractor**

With 'root' displayed, press *P* which will reveal the root extractor status. The root extractor can be turned on or off by the *Up* or *Down* buttons. Select 'OFF', and press *E* to return to the main menu.

**Step 3 Select frequency of maximum rejection**

Scroll through the main menu until 'Cond' is displayed. Enter the sub-menu by pressing *P* twice and select the 'FrE' function. Using the *Up* or *Down* buttons select '50', and then press *E* twice to return to the main menu.

**Step 4 Define function of P push-button**

Select 'C--P' from the main menu and press *P* to reveal the function of the *P* button in the display mode. Select '4-20' and return to the main menu by pressing *E*.

**Step 5 Position dummy decimal point**  
 Select 'd.P' from the main menu and then press *P*. Using the *Up* and *Down* push-buttons position the dummy decimal point in front of the least significant digit.  
 Press *E* to return to the main menu.

**Step 6 Calibrate display**  
 With any input current between 4 and 20mA select 'SEt' from the main menu and press *P*. The indicator will display 'ZEro' in the sub-menu; press *P* to reveal the existing zero display. Using the *Up*, *Down* and *P* push-buttons enter the required zero display of -50.0  
 Press *E* to return to the 'ZEro' prompt.

Again with any input current between 4 and 20mA press the *Up* push-button and the indicator will display 'SPAn'. Press *P* to reveal the existing span display. Using the *Up*, *Down* and *P* push-buttons enter the required span display of 1050.0 Press *E* to return to the 'SPAn' prompt. Press *E* again to return to the main menu.

**Step 7 Return to display mode**  
 Following completion of calibration return to the display mode by pressing '*E*'.

## 7. MAINTENANCE

### 7.1 Fault finding during commissioning

If a BA524D fails to function during commissioning the following procedure should be followed:

Symptom	Cause	Solution
No display	Incorrect wiring	There should be 1V between terminals 1 & 3 with terminal 1 positive.
No display and no volts between terminals 1 and 3.	Incorrect wiring or no power supply.	Check that a current is flowing in the loop.
	Insufficient loop voltage to operate indicator	Check supply voltage and voltage drops caused by all components in the loop.
Indicator displays 1	Positive over-range	The indicator has been incorrectly calibrated & is trying to display a number greater than 19999.
Indicator displays -1	Negative Over-range	The indicator has been incorrectly calibrated & is trying to display a number less than -19999.
Unstable display	4/20mA input has a large ripple content.	Check loop supply voltage.
Unable to enter the programme mode	Incorrect security code entered.	Enter correct security code or fit security link in override position. See Fig 7.

## 7.2 Fault finding after commissioning

### ENSURE PLANT SAFETY BEFORE STARTING MAINTENANCE

If a BA524D fails after it has been functioning correctly, the following table may help to identify the cause of the failure.

Symptom	Cause	Solution
No display and no volts between terminals 1 and 3.	No power supply	Check that a current is flowing in the loop.
Unstable display	4/20mA input has a large ripple.	Check loop supply voltage.
Incorrect calibration	Digital filter FrE has been changed after indicator was calibrated.	Recalibrate

If this procedure does not reveal the cause of the fault, it is recommended that the instrument is replaced. This can be done without disconnecting power, but while the indicator is disconnected the 4/20mA loop will be open circuit. Alternatively the electronic assembly may be exchanged as described in section 7.3

### 7.3 Servicing

To simplify servicing all BA524D indicators use a common display assembly which can be easily replaced on site. Depending upon the accessories fitted, one spare display assembly may be used to repair any BA524D which fails. The exchange may be made without disconnecting power, the 4/20mA loop will continue to function but the indicator voltage drop will increase from 1V to 4V without the display assembly.

To exchange the display assembly remove the terminal cover by unscrewing the two 'A' screws which will reveal two concealed 'D' screws. If the instrument is fitted with external push-buttons also unscrew the two 'C' screws securing the buttons and un-plug the five way connector. Finally unscrew all four 'D' screws identified in Fig 4 and carefully lift off the front of the instrument. The instrument assembly is secured by three Pozi headed screws which should be removed.

If the instrument is fitted with a backlight or alarms the fly-leads connecting the accessory boards to the terminals should be un-plugged. The replacement display assembly may then be installed and the enclosure reassembled.

If after replacement of the display assembly the instrument still does not function, it is likely that the fault is within the protection components on the terminal assembly. Terminal assemblies may be exchanged on site providing the replacement assembly includes terminals for any accessories fitted i.e. backlight and alarms.

We recommend that faulty instruments and instrument assemblies are returned to BEKA associates or to our local agent for repair.

### 7.4 Routine maintenance

The mechanical condition of the instrument and electrical calibration should be regularly checked. The interval between inspections depends upon environmental conditions. We recommend that initially instrument calibration should be checked annually.

### 7.5 Guarantee

Indicators which fail within the guarantee period should be returned to BEKA associates or our local agent. It is helpful if a brief description of the fault symptoms is provided.

### 7.6 Customer comments

BEKA associates is always pleased to receive comments from customers about our products and services. All communications are acknowledged and whenever possible, suggestions are implemented.

**8. ACCESSORIES**

**8.1 Units of measurement and instrument identification**

All BA524D indicators are fitted with a blank label around the liquid crystal display. This label can be supplied printed with any units of measurement and tag information specified at the time of ordering. Alternatively the information may be added on-site via an embossed strip, dry transfer or a permanent marker.

To gain access to the display label remove the terminal cover by unscrewing the two 'A' screws which will reveal two concealed 'D' screws. If the instrument is fitted with external push-buttons also unscrew the two 'C' screws securing the buttons and un-plug the five way connector. Finally unscrew the four 'D' screws and carefully lift off the front of the instrument - see Fig 4. Add the required legend to the display label, or replace with a new pre-printed label which is available from BEKA associates

The BA524D can also be supplied with a blank or custom engraved stainless steel plate secured by two screws to the side of the instrument enclosure. This plate can accommodate:

- 1 row of 9 alphanumeric characters 10mm high
- or 1 row of 11 alphanumeric characters 7mm high
- or 2 rows of 18 alphanumeric characters 5mm high.

**8.2 Alarms**

The BA524D can be supplied with two solid state single pole alarm outputs which may be independently programmed as high or low alarms with normally open or normally closed outputs. Fig 8 illustrates the conditions available and shows which are fail safe, i.e. output is in the alarm condition (open) when the 4/20mA input current is zero.

**WARNING**

**These alarm outputs should not be used for critical safety applications such as a shut down system.**

When an alarm is activated, the BA524D display alternates between the measured value and an alarm identification.

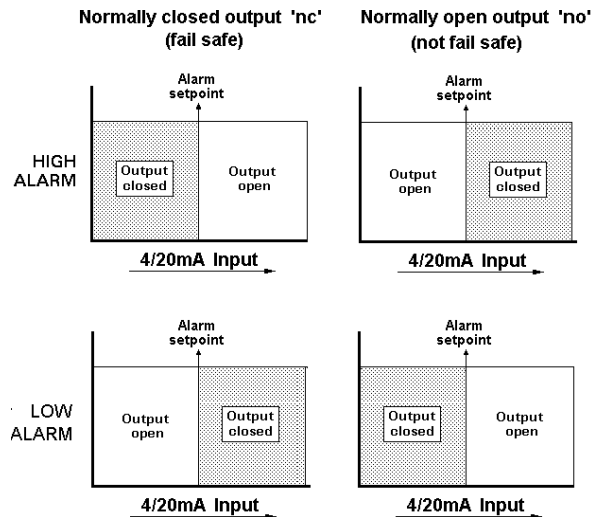

Fig 8 Alarm outputs

Programmable functions for each alarm include adjustable setpoint, hysteresis, alarm delay and alarm accept.

**8.2.1 Solid state output**

Each alarm has a galvanically isolated single pole solid state switch output as shown in Fig 9. The outputs are polarised and current will only flow in one direction. Terminals 8 and 10 should be connected to the positive side of the supply.

$$\begin{aligned} R_{on} &= 50\text{hms} + 0.6V \\ R_{off} &= \text{greater than } 180k \end{aligned}$$

Note: Because of the series protection diode some test meters may not detect a closed alarm output.

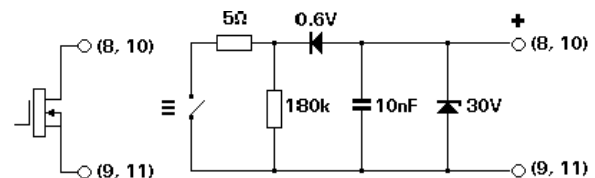

Fig 9 Equivalent circuit of each alarm output

Figure 10 shows a typical application for the BA524D indicator with alarms. A solenoid valve is controlled by one alarm output, while the second alarm output operates a sounder.

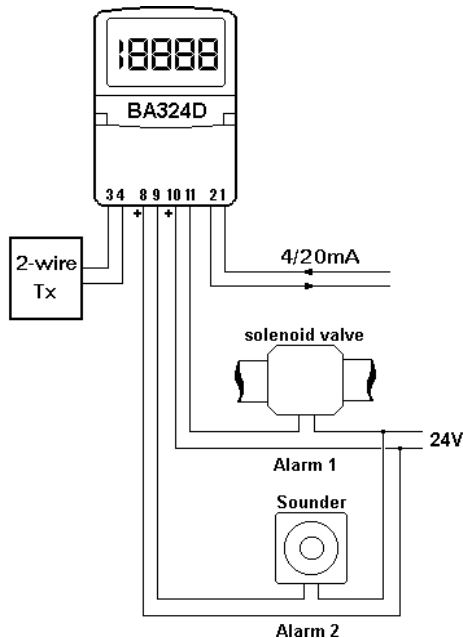

Fig 10 Typical alarm application

### 8.2.2 Programming and adjustment

When an alarm card is added to a BA524D the main programme menu is extended as shown in Fig 11. The additional functions appear between 'Cond' and 'C--P' in the main menu. For simplicity Fig 11 only shows the additional functions available on alarm 1, but alarm 2 has identical facilities.

The following table summarises each of the alarm programme functions and includes a cross reference to more detailed information. Again only the functions on alarm 1 are listed, but alarm 2 has identical facilities

### Summary of programmable alarm functions

Display	Description of function
'EnbL'	<b>Alarm enable</b> Enables or disables the alarm function without changing the alarm parameters. See section 8.2.3
'SP1'	<b>Alarm setpoint 1</b> Adjusts the alarm setpoint. The alarm is activated when the indicator display equals the setpoint. See section 8.2.4
'HI.LO'	<b>Alarm function</b> Defines whether the alarm has a high or low function. See section 8.2.5
'no.nc'	<b>Normally open or normally closed output</b> Determines whether the single pole alarm output is open or closed in the alarm condition. See section 8.2.6
'HStr'	<b>Hysteresis</b> Adjusts the alarm hysteresis. See section 8.2.7
'dELA'	<b>Alarm delay time</b> Adjusts the delay between the display equalling the setpoint and the alarm output being activated. See section 8.2.8
'SIL'	<b>Alarm silence time</b> Defines the time that the alarm output remains in the non-alarm condition following acceptance of an alarm. See section 8.2.9
'AcSP'	<b>Access setpoint</b> Sub-menu which enables direct access to the alarm setpoints from the indicator display mode, and defines a separate security code. See section 8.2.10



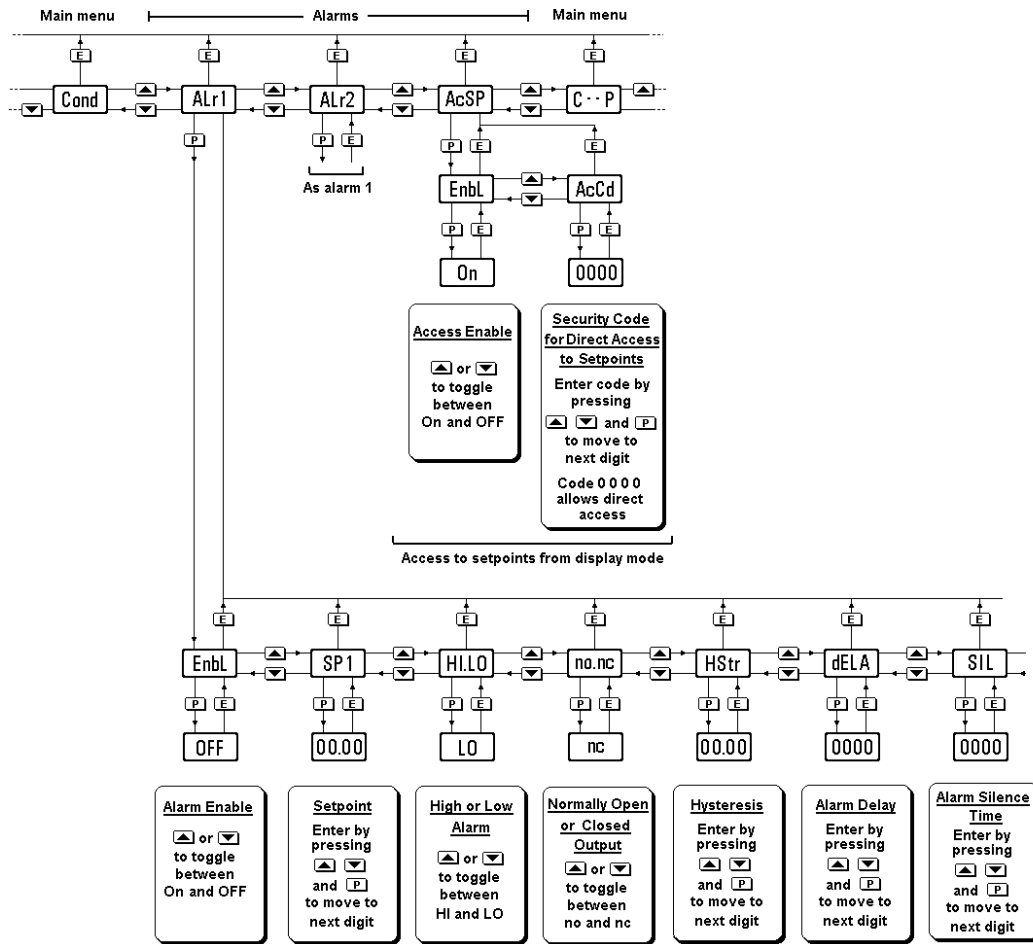

Fig 11 Alarm programme menu

**8.2.3 Alarm enable: EnbL**

This function allows the alarm to be enabled or disabled without altering any of the alarm parameters. To check or change the function select 'EnbL' from the alarm menu and press *P* which will reveal the current setting. The function can be changed by pressing the *Up* or *Down* button followed by the *E* button to return to the alarm menu.

**8.2.4 Setpoint adjustment: SP1 and SP2**

The setpoint of each alarm may be positioned anywhere between -19999 and 19999 providing this corresponds to an input current between 3.8 and 20.2mA. e.g. If the indicator has been calibrated to display 0 with 4mA input and 10000 with 20mA input, the two alarm setpoints may be positioned anywhere between -125 and 10125. To adjust the setpoint select 'SP1' or 'SP2' from the alarm menu and press *P* which will reveal the existing alarm setpoint. Each digit of the setpoint can be adjusted using the *Up* and *Down* push-buttons, and the *P* button to move to the next digit. When the required setpoint has been entered press *E* to return to the alarm menu.

### 8.2.5 Alarm function: HI.LO

Each alarm can be conditioned as a high or low alarm. To check or change the alarm function select 'HI.LO' from the alarm menu and press *P* to reveal the current setting. The function can be changed by pressing the *Up* or *Down* buttons followed by the *E* button to return to the alarm menu.

### 8.2.6 Alarm output status: no.nc

This function allows the alarm output to be open or closed in the alarm condition. When deciding which is required, care must be taken to ensure that the alarm output is fail safe. See Fig 8.

#### CAUTION

**When the 4/20mA supply is removed both alarm outputs will open irrespective of conditioning. Therefore for fail safe operation both alarm outputs should be programmed to be open in the alarm condition.**

To check or change the alarm output status select 'no.nc' from the alarm menu and press *P* reveal the current setting. The function can be changed by pressing the *Up* or *Down* button followed by the *E* button to return to the alarm menu.

### 8.2.7 Hysteresis: HStr

During programming hysteresis is shown in the units the indicator has been calibrated to display. To adjust the hysteresis, select 'HStr' from the alarm menu and press *P* which will reveal the existing figure. Each digit can be adjusted using the *Up* and *Down* push-buttons, and the *P* button to move to the next digit. When the required hysteresis has been entered, press *E* to return to the alarm menu.

e.g. An indicator calibrated to display 0 to 10000, with a high alarm set at 9000 and hysteresis of 200 will perform as follows:

High alarm will be activated when display equals or exceeds 9000, but will not reset until the display falls below 8800.

### 8.2.8 Alarm delay: dELA

This function enables activation of the alarm output to be delayed for a fixed time following the alarm condition occurring. The delay can be programmed in 1 second increments up to 3600 seconds. If a delay is not required zero should be entered. To adjust the delay select 'dELA' from the alarm menu and press *P* which will reveal the existing delay. Each digit of the delay can be adjusted using the *Up* and *Down* push-buttons, and the *P* button to move to the next digit. When the required delay has been entered, press *E* to return to the alarm menu.

### 8.2.9 Alarm silence time: SIL

This function is primarily intended for use in small installations where the alarm output directly operates an annunciator such as a sounder. When the alarm silence time is set to any figure other than zero, the *P* push-button becomes an alarm accept button. After an alarm has occurred, operating the *P* button will cause the alarm output to revert to the non-alarm condition for the programmed alarm silence time. The display will continue to indicate an alarm after it has been accepted and silenced. The alarm silence time may be adjusted between 0 and 3600 seconds in 1 second increments.

To adjust the alarm silence time select 'SIL' from the alarm menu and press *P* which will reveal the existing time. Each digit can be adjusted using the *Up* and *Down* push-buttons, and the *P* button to move to the next digit. When the required time has been entered press *E* to return to the alarm menu.

### 8.2.10 Access Setpoint: AcSP

This function controls a separate menu which provides direct access to the alarm setpoints when the indicator is in the display mode. See section 8.2.11 for a full description. An operator may therefore adjust the alarm setpoints without having access to the programme and alarm menus. Further protection is provided by a separate security code.

This direct access menu is enabled and a separate security code entered from the 'AcSP' function in the programme menu as shown in Fig 11. To change the menu parameters select 'AcSP' from the programme menu and press *P* which will display the enable prompt 'EnbL'. Press *P* again to reveal if the direct access menu is 'On' or 'OFF'. The *Up* or *Down* buttons will toggle the display between the two conditions.

If 'OFF' is selected, the operator will not have access to the setpoints from the display mode. Return to the 'AcSP' prompt in the main menu by pressing *E* twice.

If 'On' is selected, the operator will have direct access to the alarm setpoints from the display mode via a separate optional security code. To define the four digit numerical code press *P* to return to the 'EnbL' prompt followed by the *Up* or *Down* button to select the access code prompt 'AcCd'. Pressing *P* will reveal the current security code. Each digit of the code may be changed by operating the *Up* and *Down* push-buttons, and the *P* button to move to the next digit. When the required code has been entered, press *E* twice to return to the 'AcSP' prompt in the Programme Menu.

Code 0000 will disable the security code allowing direct access to the setpoints by pressing the *P* and *Up* buttons simultaneously.

New instruments with alarms are supplied with this function disabled and the security code set to 0000

### 8.2.11 Adjusting alarm setpoints from the display mode

Access to the alarm setpoints from the indicator display mode is obtained by operating the *P* and *Up* push-buttons simultaneously as shown in Fig 12. If the setpoints are not protected by a security code the alarm setpoint prompt 'SP1' will be displayed. If the setpoints are protected by a security code, 'COdE' will be displayed first. Pressing *P* again will enable the alarm security

code to be entered digit by digit using the *Up* and *Down* buttons to change the flashing digit, and the *P* push-button to move to the next digit. If the correct code is entered pressing *E* will cause alarm setpoint prompt 'SP1' to be displayed. Pressing the *Up* or *Down* button will toggle the display between the two alarm setpoint prompts 'SP1' and 'SP2'.

If an incorrect security code is entered, or a button is not pressed within ten seconds, the indicator will automatically return to the display mode.

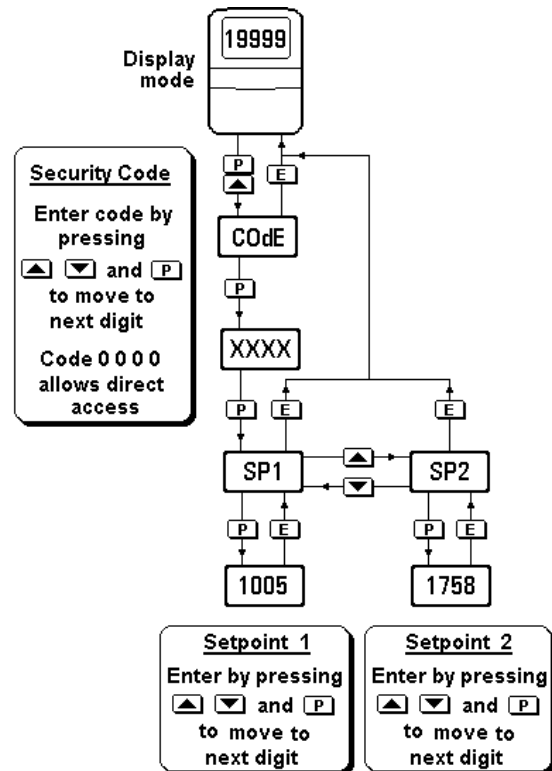

Fig 12 Setpoint adjustment from the display mode

To adjust an alarm setpoint select 'SP1' or 'SP2' and press *P* which will reveal the current setting. Each digit of the setpoint may be adjusted using the *Up* and *Down* push-buttons, and the *P* button to move to the next digit. When the required setpoint has been entered, pressing *E* will return the display to the 'SP1' or 'SP2' prompt from which the other setpoint may be selected, or the indicator may be returned to the display mode by pressing *E* again.

Direct access to the alarm setpoints is only available when the menu is enabled - see section 9.2.10

### 8.3 Lineariser

The indicator can be supplied with a sixteen point lineariser which may be adjusted to compensate for almost any non linear variable. For example, a level signal from a horizontal cylindrical tank may be linearised by the indicator to display the tank contents in linear volumetric units.

The addition of linearising software does not affect the intrinsic safety of the indicator.

Fig 13 shows a typical linearising characteristic. Up to sixteen break-points may be programmed to occur at any input current between 4 and 20mA. The slope between adjacent break-points may be set anywhere between -1250 and +1250 display counts per milliamp. Greater slopes may be programmed, but the indicator performance will be degraded. A linear characteristic can be obtained by programming just two points, one at 4mA and the other at 20mA.

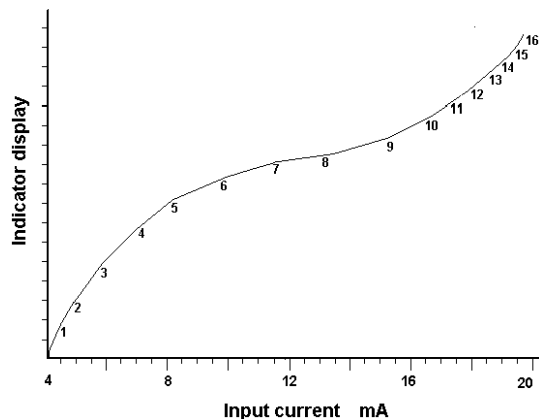

Fig 13 Typical indicator characteristic

The lineariser software does not change the main programme menu, but the 'CAL' and 'SET' functions are extended as shown in Fig 14. As with a linear indicator, calibration may be performed with an external calibrator using the 'CAL' function, or from the internal references using the 'Set' function.

#### 8.3.1 Calibration using an external current source

This method allows direct calibration with a current source, and is preferred when traceability is required. If the exact system non-linearity is unknown, this method also allows direct calibration from the variable to be displayed. e.g. The output from a level sensor in an irregular tank may be displayed in linear volumetric units by filling the tank with known

incremental volumes and calibrating the indicator to display the sum of the increments at each break-point.

The number of break-points required should first be entered using the 'Add' and 'dEL' functions. In both these functions the indicator initially displays the current break-point and the total number of break-points being used. e.g.

<b>5</b>	<b>13</b>
current break-point	total number of break-points

#### Display Description of function

##### 'Add' Add a break-point

Adds a new break-point before the displayed break-point. The calibration of existing break-points is not changed, but the identification number of all subsequent break-points is increased by one.

##### 'dEL' Remove a break-point

Removes the displayed break-point and joins the preceding break-point to the following break-point with a straight line. The identification number of all subsequent break-points is decreased by one.

To add a break-point select 'CAL' from the main menu and press *P* to enter the 'Add' function; press *P* again to reveal the current and total number of break-points. Each subsequent operation of the *P* push-button will introduce an additional break-point. When adding a break-point to a calibrated indicator, the insertion position can be selected using the *Up* and *Down* push-buttons.

The delete break-point function 'dEL' operates in a similar manner to the 'Add' function described above.

When the required number of break-points has been entered, return to the sub-menu by pressing *E*. The indicator will display 'Add' or 'dEL' depending upon the last function used. Each break-point can now be programmed.

Select 'PtS' from the sub-menu and press *P* which will select the first break-point '0 n', where n is the total number of break-points entered.

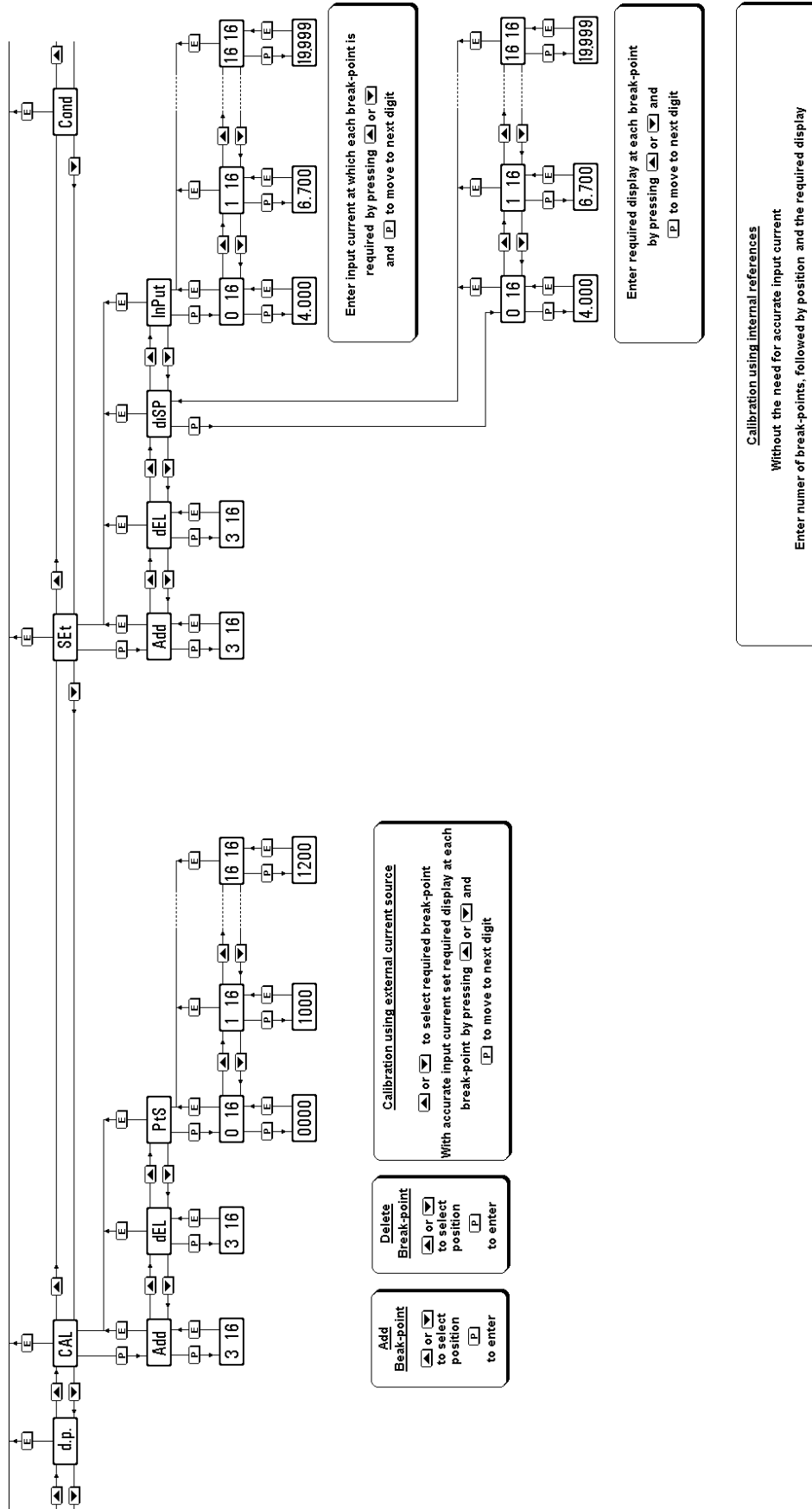

Fig 14 Lineariser programme structure

The selected break-point can be changed using the *Up* and *Down* buttons. When the required break-point has been selected press *P*. Set the indicator input current to the exact value at which the break-point is to occur, and adjust the indicator display using the *Up* and *Down* buttons and *P* to move between digits. When the required display has been set, press *E* to enter the information and return to the sub-menu from which another break-point can be selected.

Repeat this procedure for each break-point, and then return to the main menu by pressing *E* twice.

### 8.3.2 Calibration using internal references

This function enables the break-points to be adjusted without the need for an accurate external current source. Throughout calibration the indicator input current may be any value between 4 and 20mA.

The accuracy of this method depends upon the accuracy of the internal references which should be calibrated periodically against a traceable external current source with a resolution of at least 0.4µA. See section 5.7.2

The number of break-points required should first be entered using the Add and dEL functions. In both these functions the indicator initially displays the current break-point and the total number of break-points being used. e.g.

<b>5</b>	<b>13</b>
current break-point	total number of break-points

<b>Display</b>	<b>Description of function</b>
----------------	--------------------------------

<b>'Add'</b>	<b>Add a break-point</b> Adds a new break-point before the displayed break-point. The calibration of existing break-points is not changed, but the identification number of subsequent break-points is increased by one.
--------------	---

<b>'dEL'</b>	<b>Remove a break-point</b> Removes the displayed break-point and joins the preceding break-point to the following break-point with a straight line. The identification of subsequent break-points is decreased by one.
--------------	--

<b>Display</b>	<b>Description of function</b>
----------------	--------------------------------

<b>'InPut'</b>	<b>Defines the current at which break-point occurs</b>
----------------	--

Enables the required current at each break-point to be defined without having to input an accurate input current to the indicator.

<b>'diSP'</b>	<b>Defines display at break-point</b>
---------------	---------------------------------------

Enables the indicator display at each break-point to be defined.

Select 'SET' from the main menu and press *P* once to enter the 'Add' function, and again to reveal the current and total number of break-points. Each subsequent operation of the *P* push-button will introduce an additional break-point. When adding a break-point to a calibrated indicator, the insertion position can be selected using the *Up* and *Down* push-buttons.

The delete break-point function 'dEL' operates in a similar manner to the 'Add' function described above.

When the required number of break-points has been entered, return to the sub-menu by pressing *E*. The indicator will display 'Add' or 'dEL' depending upon the last function used. The required indicator display at each break-point can now be entered, followed by the input current at which each break-point occurs.

To enter the required display at any break-point select 'diSP' from the sub-menu and press *P* which will select the first break-point '0 n', where 'n' is the total number of break-points selected. The selected break-point can be changed using the *Up* and *Down* buttons. When the required break-point has been selected press *P* to reveal the existing display. Using the *Up* and *Down* buttons and *P* to move between digits set the revised display. Press *E* to return to the sub-menu from which another break-point can be selected. Repeat this procedure for all the break-point displays to be changed, and then return to the 'diSP' prompt in the sub-menu by pressing *E*.

To enter the input current at which each break-point occurs select 'InPut' from the sub-menu and press *P* which will select the first break-point '0 n'. The selected break-point can be changed using the *Up* and *Down* buttons. When the required break-point has been selected, press *P* to reveal the input current at which the break-point occurs. Using the *Up* and *Down* buttons and *P* to

move between digits, set the revised input current in mA. Press *E* to return to the sub-menu from which another break-point can be selected.

Repeat this procedure for all the break-point input currents to be changed, and then return to the 'InPut' prompt in the sub-menu by pressing *E*.

#### 8.4 Tare function

The tare function is a factory fitted software accessory, primarily intended for use with weighing systems.

When the tare software is installed, pushing and holding the *P* button for more than 3 seconds sets the indicator display to zero irrespective of the input current, and activates the tare annunciator, an arrow on the top left hand corner of the display. Subsequent operation of the *P* push-button for less than 3 seconds will toggle the indicator between the normal gross display and the net display with the tare annunciator activated.

The tare function allows an operator to quickly zero the indicator display at any input current so that subsequent readings only show the change in input since the *P* push-button was operated. For example when used with a weighing system, it allows the weight of a container to be automatically subtracted from the total gross weight so that only the net weight of the contents is displayed.

#### 8.5 Display backlight

The BA524D can be supplied with LED backlighting to improve display contrast when the indicator is installed in poorly illuminated areas. The backlight is electrically isolated from the measuring circuit and may be powered from any 18 to 30V dc supply. The backlight brilliance may be reduced by reducing the supply voltage below 18V, or by fitting a current limiting resistor in series with the supply.

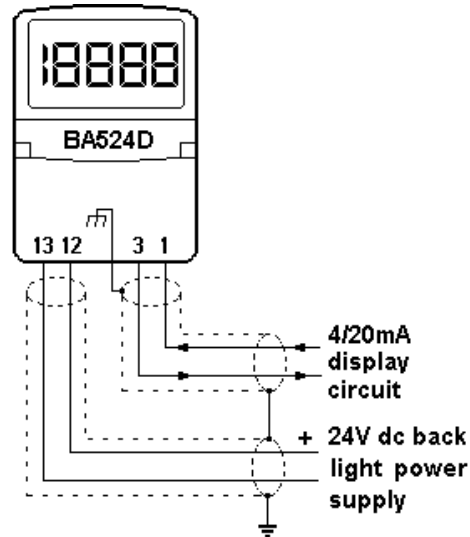

Fig 15 Backlight powered by Zener barrier

#### 8.6 External switches

For applications requiring frequent access to the programme menus the BA524D can be supplied with an external membrane keypad. These switches, which maintain the IP66 integrity, allow all functions to be controlled without removing either of the enclosure covers.

#### 8.7 Pipe mounting kits

Two pipe mounting kits are available for securing the BA524D to a horizontal or vertical pipe.

- BA392D Stainless steel bracket secured by two worm drive hose clips. Will clamp to any pipe with outside diameter between 60 and 80mm.
- BA393 Heavy duty stainless steel bracket secured by a single 'V' bolt. Will clamp to any pipe with an outside diameter between 40 and 80mm.

#### 8.8 Stem mounting kit

The BA395 stem mounting kit comprises a short length of stainless steel conduit with a male M20 x 1.5 thread at both ends. Primarily intended for use with flow transmitters, the kit enables the BA524D indicator to be mounted directly onto the transmitter.