

BA374C
Intrinsically safe
field mounting
indicating temperature
transmitter

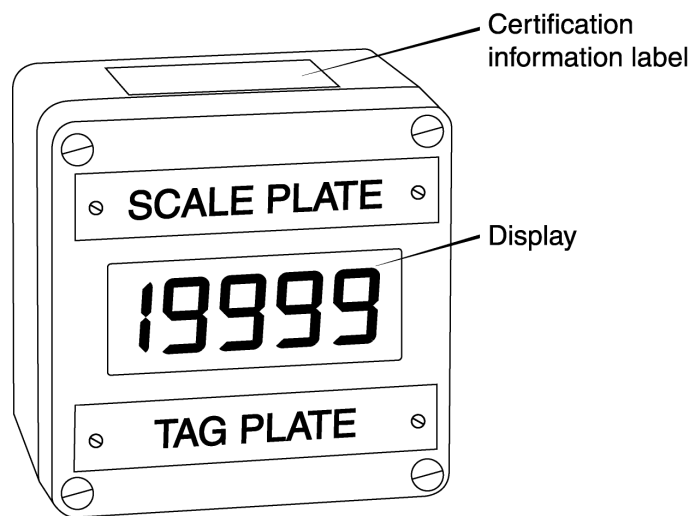

CONTENTS

- 1. Description**
 - 2. Operation**
 - 2.1 Controls
 - 3. Intrinsic Safety Certification**
 - 3.1 ATEX certificate
 - 3.2 Other intrinsic safety certifications
 - 3.3 Zones, Gas Groups and T rating
 - 3.4 Certification information label
 - 3.5 Input terminals 1, 2, 3 & 4
 - 3.6 4/20mA output - Terminals 5 & 6
 - 4. Electrical System Design for Installations in Hazardous Areas**
 - 4.1 Using Zener barriers
 - 4.2 Using galvanic isolators
 - 5. Installation**
 - 5.1 Location
 - 5.2 Installation procedure
 - 5.3 EMC
 - 6. Programming and calibration**
 - 6.1 Summary of programme menu functions.
 - 6.2 Description of programme menu functions.
 - 6.2.1 Transmitter input
 - 6.3 For thermocouple inputs
 - 6.3.1 Types of thermocouple
 - 6.3.2 Display units
 - 6.3.3 Display resolution
 - 6.3.4 Cold junction compensation
 - 6.3.5 Input open circuit drive
 - 6.4 For resistance thermometer inputs
 - 6.4.1 Type of resistance thermometer
 - 6.4.2 Display units
 - 6.4.3 Display resolution
 - 6.5 For voltage inputs
 - 6.5.1 Position of display decimal point
 - 6.5.2 Low input & display calibration
 - 6.5.3 High input & display calibration
 - 6.6 4/20mA output current calibration
 - 6.7 Security code
 - 6.8 Calibrating the internal references
 - 6.8.1 Conditioning internal references
 - 6.8.2 Voltage input reference
 - 6.8.3 3-wire RTD reference
 - 6.8.4 4-wire RTD reference
 - 6.8.5 Output current reference
 - 7. Trim menu**
 - 7.1 Calibration procedure using trim menu
 - 7.2 Periodic re-calibration using trim menu
 - 8. Calibration example**
 - 9. Maintenance**
 - 9.1 Fault finding during commissioning
 - 9.2 Fault finding after commissioning
 - 9.3 Servicing
 - 9.4 Routine maintenance
 - 9.5 Guarantee
 - 9.6 Customer comments
- Accessories**
- 10. Identification and mounting**
 - 10.1 Engraved scale and tag plates
 - 10.2 Pipe mounting kits
 - 10.3 Panel mounting kits
 - 11. Alarms**
 - 11.1.1 Solid state output
 - 11.1.2 Intrinsic safety
 - 11.1.3 Programming and adjustment
 - 11.2 Summary of programmable functions
 - 11.3 Description of programmable functions
 - 11.3.1 Alarm enable
 - 11.3.2 Setpoint adjustment
 - 11.3.3 Alarm function
 - 11.3.4 Alarm output status
 - 11.3.5 Hysteresis
 - 11.3.6 Alarm delay
 - 11.3.7 Alarm silence time
 - 11.3.8 Access setpoint
 - 11.4 Adjusting alarm setpoints from display mode
 - 12. Backlight**

The BA374C is CE marked to show compliance with the European Explosives Atmospheres Directive 94/9/EC and the European EMC Directive 98/336/EEC

A Quick Guide to the Use of this Instruction Manual

Your BA374C has been factory set to the requirements specified on your purchase order. If no requirements were given, the instrument will be supplied with default settings i.e. 3 wire RTD input; high resolution display in °C; 4 to 20mA output corresponding to an input and display of 0.0 to 100.0°C.

If the BA374C is set to your requirements before putting it into use you should refer to:

Section 4	Electrical System Design
Section 5	Installation
Section 2.1	Controls

If optional alarms are fitted you should refer to Section 11.

You will also find the 'Trim' menu described in Section 7 useful if you wish to calibrate the complete control loop.

If the BA374C has been supplied with default settings and you wish to change these you will need to refer to:

Section 6	Programming and Calibration
-----------	-----------------------------

This section explains the programme functions of the push-buttons and leads you through the various stages of programming the unit. Among the sub-divisions of Section 6 you will find information on setting up for:

Section 6.3	Thermocouple input
Section 6.4	Resistance thermometer input
Section 6.5	Voltage input

A word of warning: Section 6.8 explains how you can calibrate the instrument's internal references. It is only necessary to carry out this operation if you will be using these internal references to calibrate the instrument display, *i.e not using an external calibrator*, and then only annual or less frequent adjustment is required. **It is not necessary to calibrate these references before putting the BA374C into operation**, we've already done that for you. For this reason the calibration section of the programme menu is protected by an additional security code. You should only enter this section of the programme if you are sure that you want to carry out this calibration.

By following the notes in this manual you should be able to set up your BA374C without any problem. However, If you do run into difficulties Section 9 provides some guidance on typical problems you may find during commissioning. If you still have difficulties please contact our Sales Department (01462 438301). Our Sales Engineers will be able to talk you through the procedure.

1. DESCRIPTION

The BA374C is an intrinsically safe 4/20mA loop powered transmitter incorporating a large easy to read display. The instrument may be programmed on-site to accept most common thermocouples and resistance thermometers, and will provide a linear 4/20mA output proportional to temperature, plus a display in °C or °F. Voltage inputs may be scaled allowing the BA374C to display variables other than temperature.

Optional alarms provide two galvanically isolated solid state outputs which may be independently programmed for high or low operation. For installations in poorly illuminated areas an optional display backlight is available.

The BA374C transmitter has been designed in accordance with EN50014 & EN50020, and has been issued with an EC-Type Examination Certificate confirming compliance with the European ATEX Directive 94/9/EC.

The BA374C transmitter is available in a glass reinforced polyester (GRP), or an epoxy painted aluminium enclosure, both provide IP66 protection.

measurement applies linearisation using look-up tables stored in permanent memory. The

resulting temperature is shown on the internal display and controls the 4/20mA output current. The transmitter and the optional alarms are powered from the 4/20mA current loop, but the optional display backlight requires a separate supply.

Each time power is applied to the instrument, initialisation is performed. After a short delay the following display sequence occurs:

-1.8.8.8.8	Display test in which all segments of the display are activated for 2.5 seconds.
. . . .	For 1 second
0	For less than 0.5 seconds.
Input signal displayed	Using calibration information stored in instrument memory.

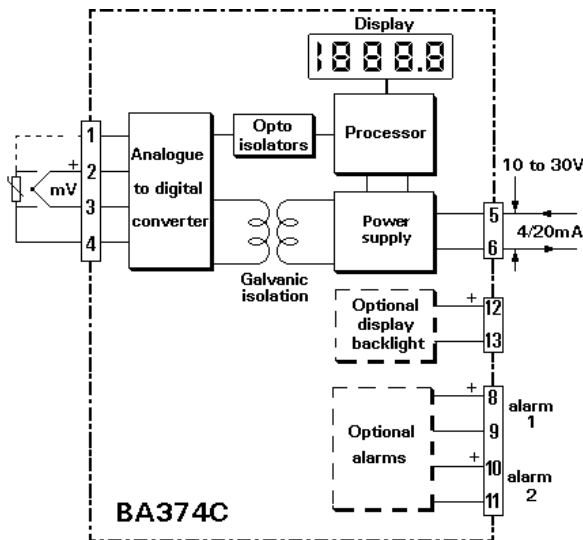

Fig 1 Simplified block diagram

2. OPERATION

Fig 1 shows a simplified block diagram of the transmitter. The input signal, which may be from a thermocouple, resistance thermometer or a dc voltage, is digitised and transferred to the instrument processor via an optical isolator. The processor scales the signal and for temperature

2.1 Controls

All functions of the transmitter can be programmed on-site via four push-buttons which are located behind the enclosure cover - see Fig 5. In the display mode i.e. when the transmitter is displaying the input signal, these push-buttons have the following functions. The 4/20mA output current is not affected when these push-buttons are operated, and when released, the input signal will again be displayed.

Button	Function
Down	While this button is pushed the transmitter will show the display corresponding to a 4mA output.
Up	While this button is pushed the transmitter will show the display corresponding to a 20mA output.
For transmitters fitted with alarms	
E+Up	While these buttons are pushed the transmitter will display setpoint 1.
E+Down	While these buttons are pushed the transmitter will display setpoint 2.

It is also possible to adjust the two alarm setpoints from the display mode - see section 11.4

3. INTRINSIC SAFETY CERTIFICATION

3.1 ATEX certificate

The BA374C has been issued with an EC-Type Examination Certificate number BAS02ATEX1185X by EECs showing compliance with the European ATEX Directive 94/9/EC for Group II, Category 1 gas atmospheres, EEx ia IIC T5. The instrument bears the Community Mark and, subject to local codes of practice, may be installed in any of the European Economic Area (EEA) countries. i.e. Austria, Belgium, Denmark, Finland, France, Germany, Greece, Ireland, Italy, Luxembourg, The Netherlands, Norway, Portugal, Spain, Sweden and the United Kingdom. ATEX certificates are also accepted in Norway, Iceland, Liechtenstein, Switzerland and the Czech Republic

This manual describes installations which conform with BS EN60079: Part 14:1997 Electrical Installation in Hazardous Areas. When designing systems for installation outside the UK, the local Code of Practice should be consulted.

3.2 Other intrinsic safety certifications

Please contact BEKA for a list of non-European intrinsic safety approvals.

3.3 Zones, Gas Groups and T rating

The BA374C and accessories have been certified EEx ia IIC T5. When connected to an approved system the transmitter may be installed in:

- Zone 0 explosive gas air mixture continuously present.
- Zone 1 explosive gas air mixture likely to occur in normal operation.
- Zone 2 explosive gas air mixture not likely to occur, and if it does, it will only exist for a short time.

Be used with gases in groups:

- Group A propane
- Group B ethylene
- Group C hydrogen

Having a temperature classification of:

- T1 450°C
- T2 300°C
- T3 200°C
- T4 135°C
- T5 100°C

This allows the BA374C to be installed in all Zones and to be used with most common industrial gases at ambient temperatures between -40 & +60°C.

Note: minimum operating temperature -20°C.

3.4 Certification information label

The certification information label is fitted on the top outside surface of the enclosure. The instrument serial number and date of manufacture are shown on a separate label inside the enclosure.

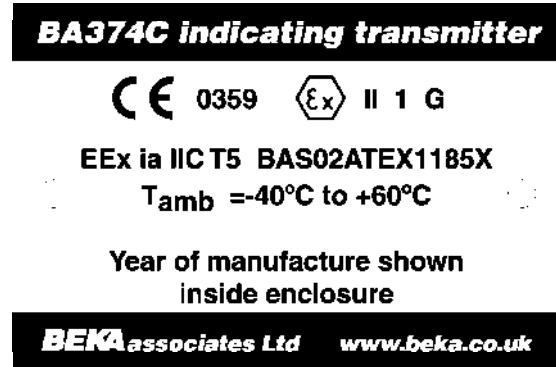

3.5 Input terminals 1, 2, 3 & 4

When the BA374C is installed in a hazardous area the input terminals may be connected to any floating or earthed sensor complying with the requirements for *simple apparatus* as defined in Clause 5.4 of EN50020:1994. i.e. the sensor generates less than 1.5V, 100mA, or 25mW.

Thermocouples and resistance thermometers are *simple apparatus* and any floating or earthed device may be connected to the BA374C, providing that both are installed within the hazardous area.

The permitted maximum parameters for the cables connecting the transmitter to the sensor are 4µF and 9.2mH in the most onerous gas group IIC (hydrogen). These are large and are very unlikely to be exceeded on any thermocouple or resistance thermometer installation.

If the transmitter input is to be connected to a device which does not comply with the requirements for simple apparatus, a system certificate should be obtained, or the safety of the system assessed using the entity concept. The certified safety description of the BA374C input terminals is:

Uo	=	8.61V
Io	=	62mA dc
Po	=	0.14W

3.6 4/20mA output - terminals 5 & 6

The BA374C transmitter is powered via these terminals, and the current drawn is the 4/20mA output signal. The transmitter is normally powered from the safe area so a Zener barrier or galvanic isolator is required to protect the circuit. Any single channel Zener barrier or galvanic isolator

certified by an EEC approved body to [EEx ia] IIC with output parameters equal to, or less than, those shown below may be used.

U _o	=	30V
I _o	=	280mA dc
P _o	=	0.85W

4. ELECTRICAL SYSTEM DESIGN FOR INSTALLATION IN HAZARDOUS AREAS

4.1 Using Zener barriers

There are three basic requirements when designing a loop incorporating the BA374C:

1. The intrinsic safety parameters of the Zener barrier must be equal to or less than:

U _o	=	30V
I _o	=	280mA
P _o	=	0.85W

2. The voltage between terminals 5 & 6 of the BA374C must be between 10 and 30V.
3. The maximum supply voltage must not exceed the maximum working voltage of the Zener barrier.

Fig 2 illustrates the simplest configuration in which a BA374C is powered from an isolated (floating) power supply. Only one barrier is required as the other wire is earthed at the barrier busbar.

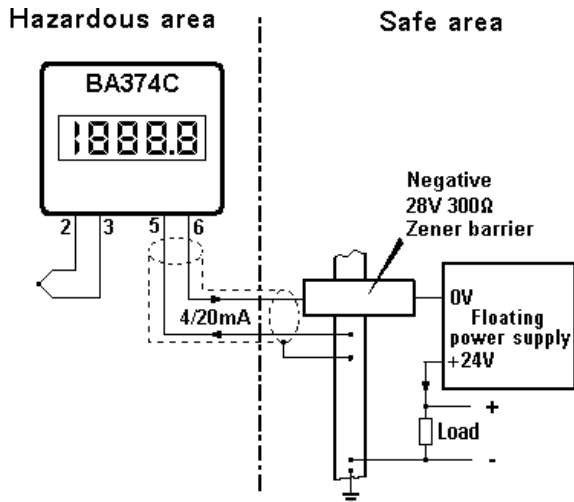

Fig 2 BA374C powered from floating supply

If a common power supply is used to operate more than one loop the negative side of the supply is normally connected to earth. To enable the negative side of the 4/20mA load also to be earthed it is necessary to have a Zener barrier in each wire going into the hazardous area as shown in Fig 3. Any certified diode return barrier may be used in the return wire. For guidance System Certificate Ex96D2505 list some of these devices.

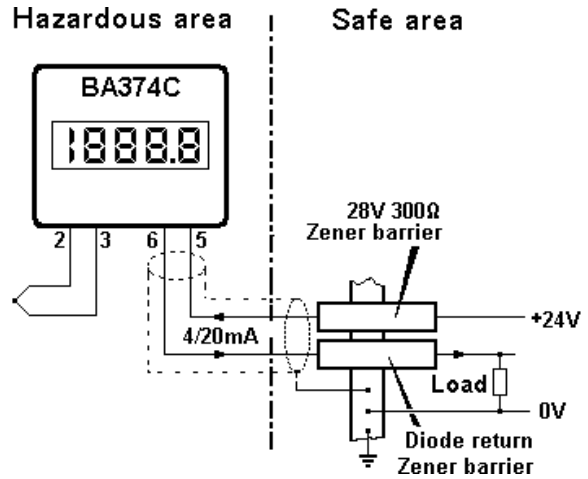

Fig 3 BA374C powered from a common supply

When designing any loop it is necessary to establish that the sum of the voltage drops caused by the BA374C transmitter, both Zener barriers, the load and the cable resistance is less than the minimum supply voltage.

For the transmitter loop shown in Fig 3:

Minimum operating voltage of BA374C	10.0V
Maximum voltage drop caused by 28V 300ohm Zener barrier (340ohms x 20mA)	6.8V
Maximum voltage drop caused by diode return barrier	1.3V
Maximum voltage drop caused by 250ohm load (250ohms x 20mA)	5.0V
Maximum voltage drop caused by cable resistance (10ohms x 20mA)	0.2V
Total maximum voltage drop	23.3V

The power supply must therefore be above 23.3V, but below the maximum working voltage of the 28V 300ohm Zener barrier which is typically 25.5V.

4.2 Using Galvanic Isolators

Galvanic isolators, although more expensive than Zener barriers, do not require a high integrity earth connection. For small systems where a high integrity earth is not already available, the use of a galvanic isolator often reduces overall installation cost and will simplify the design of the loop. Galvanic isolators also enable higher resistance loads to be driven by the 4/20mA current.

Any EEx ia IIC certified galvanic isolator with output safety parameters equal to or less than the following may be used:

$$\begin{aligned} U_o &= 30V \\ I_o &= 280mA \\ P_o &= 0.85W \end{aligned}$$

For guidance, System Certificate Ex96D2506 lists some of the devices which may be used.. Fig 4 shows a typical loop.

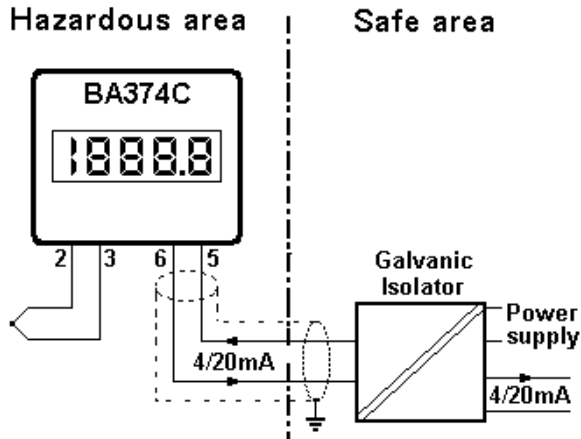

Fig 4 Typical application using galvanic isolators

5. INSTALLATION

The BA374C indicating temperature transmitter should only be installed and operated by trained competent personnel.

5.1 Location

The BA374C indicating transmitter can be supplied in either a glass reinforced polyester (GRP), or an epoxy painted aluminium enclosure. Both provide IP66 protection and have a toughened glass window and stainless steel fittings. The GRP enclosure is suitable for most industrial installations including off-shore and waste water treatment applications. For installations where solvents may be present, the aluminium enclosure provides maximum protection. The instrument should not be installed in a position where it may be attacked by aggressive substances.

The instrument must be positioned such that the environmental conditions specified by the instrument datasheet and the EC-Type Examination Certificate are not exceeded.

Please consult BEKA associates if the instrument is to be installed in an area subject to high vibration.

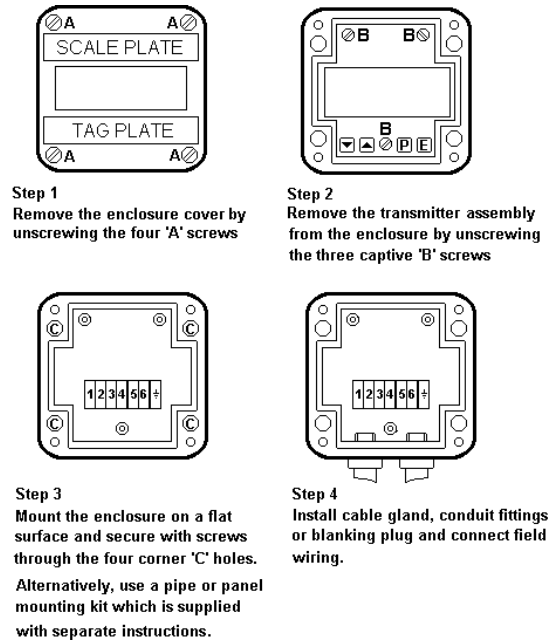

Fig 5 BA374C installation procedure

Both enclosures are surface mounting, but may be pipe or panel mounted using the accessory kits described in section 10.

To simplify installation, the enclosure may be installed and the field wiring terminated prior to the transmitter assembly being fitted. Terminal 7 is internally connected to the screen in the GRP enclosure and to the case in the aluminium enclosure.

5.2 Installation Procedure

Fig 5 illustrates the instrument installation procedure.

- Remove the enclosure cover by unscrewing the four captive 'A' screws.
- Remove the transmitter assembly from the enclosure by unscrewing the three captive 'B' screws and unplugging the flexible cable(s).
- Mount the enclosure on a flat surface and secure with screws or bolts through the four corner 'C' holes. Alternatively use one of the pipe or panel mounting kits described in section 9.
- Remove the temporary dust seals from the cable entries and install the required glands, conduit fittings or blanking plugs.

- e. Connect the field wiring to the terminals as shown in Fig 6.
- f. Replace the transmitter assembly and evenly tighten the three 'B' screws.
- g. Replace the enclosure cover and evenly tighten the four 'A' screws.

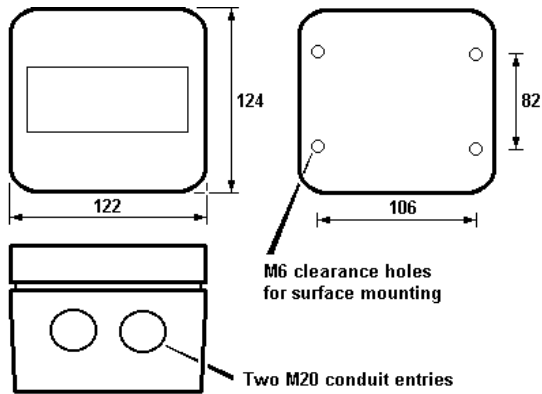

Fig 6 Dimensions and terminal connections

5.3 EMC

The BA374C complies with the requirements of the European EMC Directive. For specified immunity all wiring should be in screened twisted pairs.

6. PROGRAMMING AND CALIBRATION

The BA374C is programmed and calibrated via four push-buttons which are located behind the enclosure cover. All the functions are contained in two easy to use menus, the Programme Menu and the Trim Menu, which are shown diagrammatically in Figs 7A, 7B and 9.

The Programme Menu contains all the transmitter parameters and enables calibration to be performed against the internal transmitter references.

The Trim Menu enables the transmitter display and the 4/20mA output current to be calibrated against an external standard, such as a voltage source or temperature calibrator. This is the preferred method of calibration. A complete loop may be calibrated using this menu to minimise errors resulting from primary element and load inaccuracies.

Each function in the programme menu is summarised in section 6.1 and includes a cross reference to more detailed information in the following sections. Although this simple menu driven system enables most adjustments to be made without repeated reference to this manual, we recommend that the summary of the programme menu, calibration procedure using the trim menu and the calibration example in sections 6.1, 7.1 and 8 are read prior to changing function or calibrating the transmitter. Figs 7A, 7B and 9 show the structure of the menu.

Details of the Trim Menu are contained in section 8 which also describes periodic calibration.

When the transmitter is fitted with alarms additional functions are added to the programme menu. These are described in section 11 of this manual.

Throughout this manual push-buttons are shown in italics e.g. *P* or *Up* push-button, and legends displayed by the indicator are shown within inverted commas e.g. 'CAL' and 'ALr2'.

Access to the programme menu is obtained by operating the *P* and *E* push-buttons simultaneously. If the transmitter is not protected by a security code the first parameter 'InPut' will be displayed. If the transmitter is protected by a security code, 'COdE' will be displayed first. Pressing *P* again will enable the security code to be entered digit by digit using the *Up* and *Down* buttons to change the flashing digit, and the *P* push-button to move to the next digit. If the correct code is entered pressing *E* will cause the first parameter 'InPut' to be displayed. If an incorrect code is entered, or no button is pressed for ten seconds, the transmitter will automatically return to the operating mode.

When the transmitter is in the programme menu the 4/20mA output current will remain locked at the value prior to starting programming, and it will therefore not respond to any input change. However, calibration of the 4/20mA output via the 'CAL' function, or re-calibration of the 4/20mA reference via the 'Cond' function will change the output current.

Once within the programme menu the required parameter can be reached by scrolling through the functions using the *Up* and *Down* push-buttons as shown in Figs 7A and 7B. When returning to the display mode following changes to any parameters, the transmitter will display four decimal points for a few seconds while the new information is stored in permanent memory.

All new BA374C indicators are supplied calibrated as requested at the time of ordering. If calibration is not requested, the transmitter will be set for 3 wire RTD input with 4 to 20mA output corresponding to a display of 0.0°C to 100.0°C.

6.1 Summary of Programme Menu functions

The parameters which may be programmed vary depending upon which input is selected. For:

Thermocouple and resistance thermometer inputs

The BA374C transmitter will always display sensor temperature. Programming allows the display to be in degrees Centigrade or Fahrenheit, and for the display resolution to be selected.

Zero and span of the 4/20mA output current may be programmed to represent any display range.

Voltage input

The display may be programmed to show the input voltage in any engineering units.

Zero and span of the 4/20mA output current may be independently programmed to represent any displayed value.

Each of the functions in the programme menu is described in the following summary with a cross reference to more detailed information. Figs 7A and 7B illustrates the location of each function within the menu.

Display	Summary of Programme Menu functions
---------	-------------------------------------

'InPut'	Transmitter input Conditions the transmitter to accept thermocouple 'tHC', resistance thermometer 'rtd' or a voltage 'UOLT' input. See section 6.2.1
----------------	---

For Thermocouple Inputs

Display	Summary of Programme Menu functions
---------	-------------------------------------

'tYPE'	Sensor type Selects the type of thermocouple input. See section 6.3.1
'dEg'	Units of display Sets display to °C or °F. See section 6.3.2
'rESn'	Display resolution Selects low or high display resolution. See section 6.3.3
'CJC'	Cold junction compensation Turns thermocouple cold junction compensation ON or OFF. See section 6.3.4
'burn'	Input open circuit drive Selects up scale drive, down scale drive or no drive when input is open circuit. See section 6.3.5

For Resistance Thermometer Inputs

'tYPE'	Sensor type Selects 3-wire, 4-wire or differential Pt100 resistance thermometer input. See section 6.4.1
'dEg'	Units of display Sets display to °C or °F. See section 6.4.2
'rESn'	Display resolution Selects low or high display resolution. See section 6.4.3

For Voltage Inputs

"d.P."	Decimal point Positions the dummy decimal point between any of the display digits or turns it off. See section 6.5.1
'In-LO'	Low input sub-menu Enables the lower voltage input 'InPut' and the corresponding display 'diSP' to be defined. See section 6.5.2

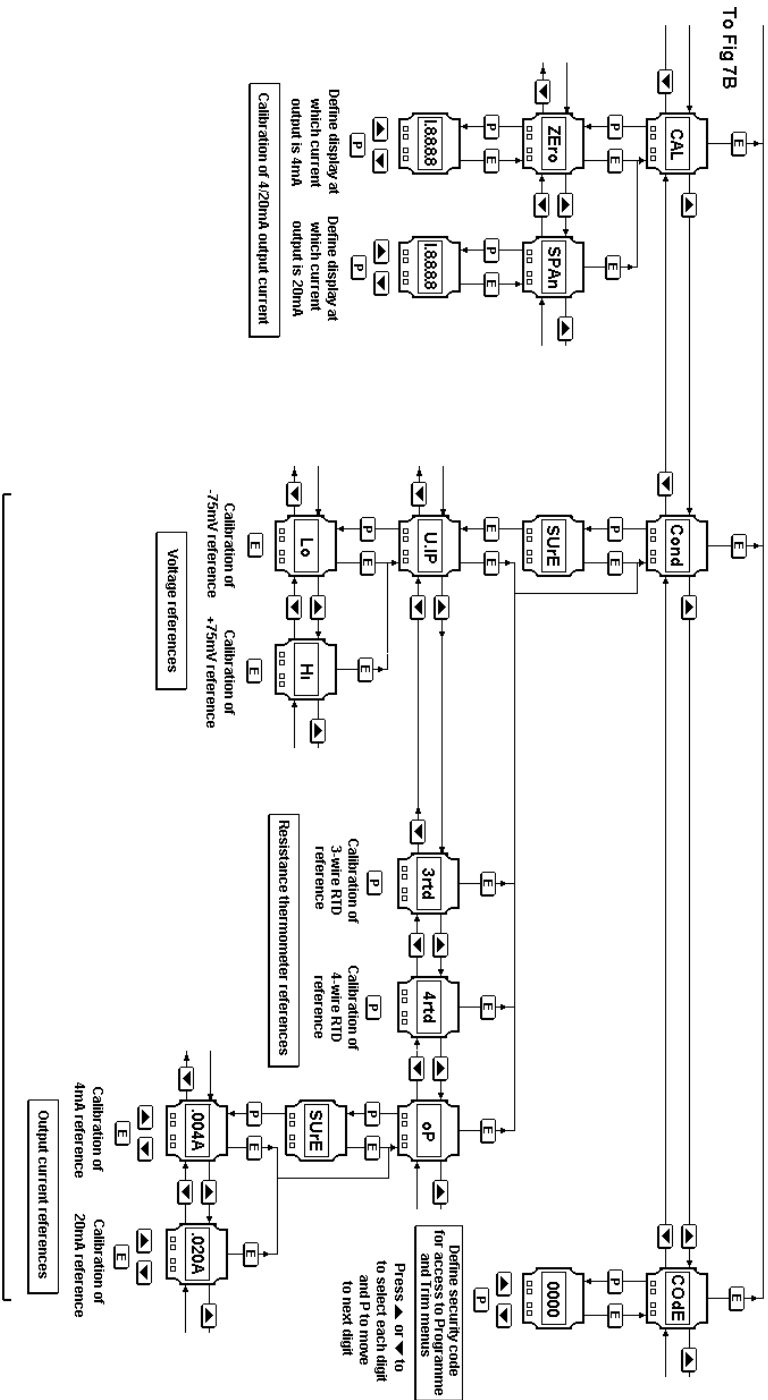

CAUTION!

Section 5.8 explains how to calibrate the instruments internal references. It is only necessary to carry out this operation if these internal references are being used to calibrate the BA674C display and output i.e. an external calibrator is NOT used. It is not necessary to calibrate these internal references before commissioning the instrument. Only enter the 'Cond' sub-menu if the references are to be re-calibrated and test equipment is available.

Fig 7A Programme Menu

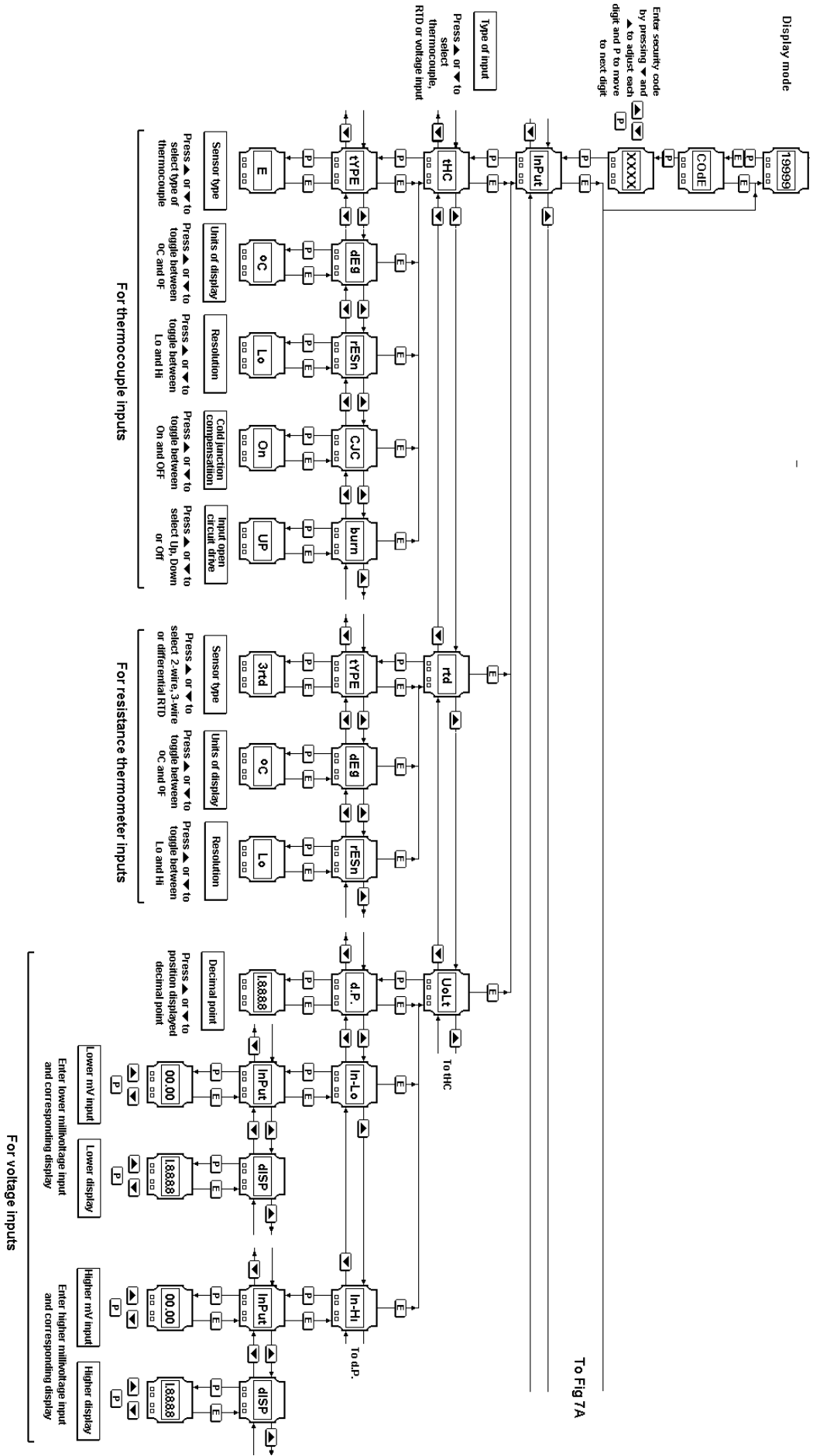

Fig 7B Programme Menu

Display Summary of Programme Menu functions

'In-HI' High input sub-menu
Enables the higher voltage input 'InPut' and the corresponding display 'diSP' to be defined.
See section 6.5.3

Other functions

'CAL' Calibration of 4/20mA output

This sub-menu defines the relationship between the transmitter 4/20mA output and the transmitter display. 'ZEro' defines the display at which the output is 4mA, and 'SPAN' the display at which the output is 20mA.
See section 6.6

'Cond' Conditioning of internal references

WARNING!

This sub-menu is password protected. It is not necessary to carry out this operation before putting the instrument into service.

This sub-menu enables the internal references to be calibrated against external voltage, resistance and current standards.

If the Trim Menu is used to calibrate the transmitter, the internal references do not require routine re-calibration.
See section 6.8

'COdE' Security code

Defines a four digit numeric code which must be entered to gain access to the programme and the trim menus. Default code 0000 disables the security function and allows unrestricted access to all functions in the programme and trim menus.
See section 6.7

6.2 Description of programme menu functions

This section contains a detailed description of each function in the programme menu. It should be read in conjunction with the summaries in section 6.1 and the programme structure shown in Figs 7A and 7B.

6.2.1 Transmitter input 'InPut'

This function conditions the transmitter to accept a thermocouple 'tHC', resistance thermometer 'rtd' or a voltage 'UOLt' input. To define the transmitter input select 'InPut' from the programme menu and press *P* which will reveal the current setting. This setting may be changed by scrolling through the menu using the *Up* or *Down* buttons. When the required input is displayed, pressing *P* will reveal a sub-menu enabling the type of sensor to be selected.

6.3 For thermocouple inputs

6.3.1 Type of thermocouple 'tYPE'

After selecting a thermocouple input, pressing *P* will reveal the 'tYPE' sub-menu which contains seven different thermocouples:

Type	Display	Standard
E	E	BS4937 Part 6 : 1974
J	J	BS4437 Part 3 : 1973
K	h	BS4437 Part 4 : 1973
N	n	BS4437 Part 8 : 1986
R	r	BS4937 Part 2 : 1973
T	t	BS4937 Part 5 : 1973
Pallaplat	PALL	Pfaunder BA302e

Pressing *P* again will display the current type of thermocouple which may be changed by scroll through the menu using the *Up* or *Down* buttons. When the required type is displayed, press *E* to return to the sub-menu.

6.3.2 Display units 'dEg'

The transmitter display may be in degrees centigrade or Fahrenheit. To check or change the display units select 'dEg' from the sub-menu and press *P* to reveal the current setting. The setting may be changed by pressing the *Up* or *Down* button. When the required units is displayed, press *E* to return to the sub-menu.

6.3.3 Display resolution 'rESn'

The output of each type of thermocouple can be displayed with high or low resolution as shown below. Low resolution can improve the readability of a noisy or rapidly changing display, but does not degrade the performance of the 4/20mA analogue output. High resolution is only available when the transmitter is displaying temperature in °C. When °F is selected the resolution is always one degree. To check or change the display resolution select 'rESn' from the sub-menu and press *P* to reveal the current setting. The setting may be changed by pressing the *Up* or *Down* button. When the required resolution has been selected, press *E* to return to the sub-menu.

Type	Display Resolution	
	Low (Lo)	High (Hi)
E	1°C	0.1°C
J	1°C	0.1°C
K	1°C	0.2°C *
N	1°C	0.2°C *
R	1°C	0.4°C *
T	1°C	0.1°C
Pallaplat	1°C	0.2°C *

*Worst case high resolution figures are quoted, at most temperatures resolution will be greater.

6.3.4 Cold junction compensation 'CJC'

The temperature of the transmitter input terminals, the thermocouple cold junction, is measured and added to the output from the thermocouple so that the transmitter displays and transmits the temperature relative to zero degrees centigrade or Fahrenheit. If cold junction compensation is not required, e.g. for differential measurement with two thermocouples, this function enables the cold junction compensation to be turned off.

To turn the cold junction compensation on or off select 'CJC' from the sub-menu and press *P* to reveal the current status. The setting may be changed by pressing the *Up* or *Down* button. When set as required press *E* to return to the sub-menu.

6.3.5 Input open circuit drive 'burn'

If the thermocouple fails and becomes open circuit, the transmitter can be conditioned to drive the display and the 4/20mA output current up or down into a safe condition. Alternatively the drive may be turned off which will result in the display and the 4/20mA output current drifting towards zero.

To check or change the input open circuit drive select 'burn' from the sub-menu and press *P* to reveal the current setting. The setting may be changed by pressing the *Up* or *Down* button. When the required setting has been selected, press *E* to return to the sub-menu.

6.4 For resistance thermometer inputs

6.4.1 Types of resistance thermometer 'tYPE'

The transmitter may be conditioned to accept 3-wire, 4-wire or differential Pt100 resistance thermometers.

After selecting resistance thermometer input from the 'InPut' sub-menu, press *P* to reveal the 'tYPE' sub-menu. Press *P* again to display the current type of resistance thermometer which may be changed by scrolling through the menu using the *Up* or *Down* buttons. When the required type is displayed, press *E* to return to the sub-menu.

6.4.2 Display units 'dEg'

The transmitter display may be in degrees centigrade or Fahrenheit. To check or change the display units select 'dEg' from the sub-menu and press *P* to reveal the current setting. The setting may be changed by pressing the *Up* or *Down* button. When the required unit is displayed, press *E* to return to the sub-menu.

6.4.3 Display resolution 'rESn'

The output of the resistance thermometer can be displayed with high or low resolution as shown below. Low resolution can improve the readability of a noisy or rapidly changing display, but does not degrade the performance of the 4/20mA analogue output. High resolution is only available when the transmitter is displaying temperature in °C. When °F is selected the display resolution is always one degree.

To check or change the display resolution select 'rESn' from the sub-menu and press *P* to reveal the current setting. The setting may be changed by pressing the *Up* or *Down* button. When the required resolution has been selected, press *E* to return to the sub-menu.

Display Resolution	
Low	High
1°C	0.1°C

6.5 For Voltage Inputs

When the transmitter is conditioned for a voltage input both the input voltage range and the corresponding display must be programmed.

6.5.1 Position of display decimal point 'd.P.'

A dummy decimal point can be positioned between any of the display digits or it may be absent.

After selecting voltage input from the 'InPut' menu, press *P* to reveal the 'd.P.' sub-menu. Press *P* again to display the current decimal point position. The decimal point can be moved or turned off by pressing the *Up* or *Down* push-button, followed by *E* to return to the sub-menu.

6.5.2 Low input & display calibration 'In-LO'

This function defines the lower voltage input and the corresponding transmitter display. See example below:

Input mV	Transmitter Display	
-10.00	-3.000	Low input / display
12.55	3.765	High input / display

The calibration is performed using the internal references and may be made with any transmitter input voltage.

Select 'In-LO' from the menu and press *P* which will access a sub-menu containing two functions 'InPut' and "dISP'.

Select the input voltage 'InPut' and press *P* which will cause the specified lower input millivoltage to be displayed in the form XX.XX The flashing digit of the input voltage can be changed by pressing the *Up* or *Down* buttons. When the first digit is correct, pressing *P* will transfer control to the next digit. When the least significant digit has been adjusted, press *E* to return to the 'InPut' prompt, from which the display prompt 'dISP' can be selected by pressing the *Up* or *Down* button.

Pressing *P* will reveal the transmitter display corresponding to the specified low input voltage. The position of the dummy decimal point will be as defined by function 'd.P.' - see section 6.5.1

The flashing digit of the display can be changed by pressing the *Up* or *Down* buttons. When the first digit is correct, pressing *P* will transfer control to the next digit. When the least significant digit has been adjusted, press *E* to return to the "dISP' prompt.

6.5.3 High input & display calibration 'In-HI'

This function defines the higher voltage input and the corresponding transmitter display. See example below:

Input mV	Transmitter Display	
-10.00	-3.000	Low input / display
12.55	3.765	High input / display

The calibration is performed using the internal references and may be made with any transmitter input voltage.

Select 'In-HI' from the menu and press *P* which will access a sub-menu containing two functions 'InPut' and "dISP'.

Select the input voltage 'InPut' and press *P* which will cause the specified higher input millivoltage to

be displayed in the form XX.XX The flashing digit of the input voltage can be changed by pressing the *Up* or *Down* buttons. When the first digit is correct, pressing *P* will transfer control to the next digit. When the least significant digit has been adjusted, press *E* to return to the 'InPut' prompt, from which the display prompt 'dISP' can be selected by pressing the *Up* or *Down* button.

Pressing *P* will reveal the transmitter display corresponding to the specified higher input voltage. The position of the dummy decimal point will be as defined by function 'd.P.' - see section 6.5.1

The flashing digit of the display can be changed by pressing the *Up* or *Down* buttons. When the first digit is correct, pressing *P* will transfer control to the next digit. When the least significant digit has been adjusted, press *E* to return to the "dISP' prompt.

6.6 4/20mA output current calibration 'CAL'

This sub-menu defines the relationship between the transmitter display and the 4/20mA output current. The transmitter output current is derived from the transmitter display and will change if the display calibration is changed. 'ZEro' defines the display at which the output is 4mA, and 'SPAN' the display at which the output is 20mA.

To calibrate the output current select 'CAL' from the programme menu and press *P* which will access a sub-menu containing two functions. Select 'ZEro' and press *P* which will show the transmitter display at which the output current is 4mA. The flashing digit of the display can be changed by pressing the *Up* or *Down* buttons. When the first digit is correct, pressing *P* will transfer control to the next digit. When the least significant digit has been adjusted, press *E* to return to the 'ZEro' prompt, from which the span prompt 'SPAN' can be selected by pressing the *Up* or *Down* button.

Press *P* to show the transmitter display at which the output current is 20mA. The flashing digit of the display can be changed by pressing the *Up* or *Down* buttons. When the first digit is correct, pressing *P* will transfer control to the next digit. When the least significant digit has been adjusted, press *E* to return to the 'SPAN' prompt.

Note: If a complete loop including a primary element, BA374C temperature transmitter and a load are being calibrated, the Trim Menu is the preferred method. It allows the transmitter display and output current to be adjusted to compensate for inaccuracies in the other components in the loop. Details of the trim menu are contained in section 7 which also describes periodic calibration.

6.7 Security Code 'COdE'

Access to the Programme and Trim Menus may be protected by a four digit numerical security code which must be entered before access is granted. New instruments are programmed with the default security code 0000 which allows unrestricted access to both menus.

To enter a new security code select 'COdE' from the programme menu and press *P* which will cause the transmitter to display the current security code. Each digit of the code can be changed using the *Up* and *Down* push-buttons, and the *P* button to move to the next digit. When the required code has been entered press *E* to return to the main menu. The revised security code will be activated when the transmitter is returned to the display mode.

If the security code is lost, access to the programme and trim menus can be obtained by putting the security link in the override position - see Fig 8. The security code can then be viewed by selecting 'COdE' from the menu and pressing *P*.

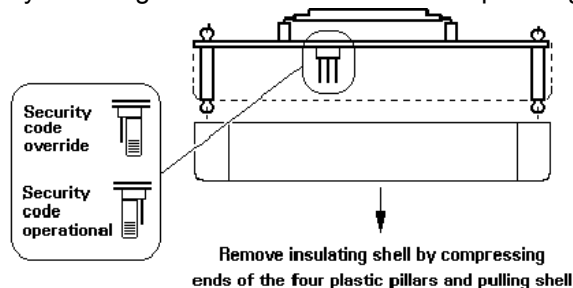

Fig 8 Location of security code override link

6.8 Calibrating the internal references

WARNING!

Changing the internal references will alter the instrument performance. Do not attempt to recalibrate these references unless you have adequate test equipment and have read the following instructions. For routine calibration of the instrument use the Trim Menu described in section 7.

If the internal references are used for calibrating the BA374C transmitter they may require periodic checking against external standards. Annual checks will produce acceptable performance, although less frequent checks are usually adequate.

If the BA374C transmitter is calibrated against an external voltage, resistance or temperature calibrator using the trim menu, the internal references should never need re-calibrating. Details of the trim menu are contained in section 7.

There are four internal references:

- Voltage input
- 3-wire RTD
- 4-wire RTD
- Current output

The input voltage reference must be adjusted first irrespective of the transmitter application, but it is only necessary to adjust the other three references if the function to which they relate is being used. For example, a BA374C with a thermocouple input from which the 4/20mA output current is being used would require the voltage input and the current output reference adjusting.

6.8.1 Conditioning internal references: 'Cond'

WARNING!

Changing the internal references will alter the instrument performance. Do not attempt to recalibrate these references unless you have adequate test equipment and have read the following instructions. For routine calibration of the instrument use the Trim Menu described in section 7.

These functions are contained in a protected sub-menu to minimise the possibility of accidental adjustment. Select 'Cond' from the menu and press *P*. The transmitter will display '0000'. Using the *Up* and *Down* buttons and the *P* button to move to the next digit enter the password 'SurE'. (Note that 'S' is entered as '5') There is a ten second time-out on password entry. Pressing *E* will then give access to the sub-menu containing the four references.

6.8.2 Voltage input reference 'U.IP'

With the BA374C input terminals connected to accurate voltage calibrator, select 'U.IP' from the 'Cond' sub-menu and press *P*. The transmitter will respond by displaying 'Lo' which is a request for an accurate -75.000mV input. Adjust the external voltage calibrator to supply -75.000mV and press *P* to store this figure in permanent memory. The transmitter will display scrolling decimal points while the reference is being updated and will then return to the 'Lo' prompt.

Select 'Hi' from the sub-menu which is a request for an accurate +75.000mV input. When the input is correct press *P* to store this figure in permanent memory. The transmitter will display scrolling decimal points while the reference is being updated and will then return to the 'Hi' prompt. This completes adjustment of the voltage input reference.

6.8.3 3-wire RTD reference '3rtd'

This adjustment, which is only necessary if the transmitter is used with a three wire resistance thermometer, should be performed after the voltage reference has been calibrated. To adjust the 3-wire RTD reference the resistance thermometer should be replaced by a 100 ohm standard resistor or calibrator, with the compensation loop remaining connected between terminals 3 and 4. It is preferable to make this substitution as close to the RTD as possible, but transmitters may be calibrated in a workshop.

Select '3rtd' from the 'Cond' sub-menu and press *P*. The transmitter will display scrolling decimal points while the reference is being updated followed by 'Ent' prior to returning to the '3rtd' prompt. This completes adjustment of this reference.

6.8.4 4-wire RTD reference '4rtd'

This adjustment, which is only necessary if the transmitter is used with a four wire resistance thermometer, should be performed after the voltage reference has been calibrated. To adjust the 4-wire RTD reference the resistance thermometer should be replaced by a 100 ohm standard resistor or calibrator, with both compensation loops from terminals 1 and 4 connected at the standard resistor or calibrator. It is preferable to make this substitution as close to the RTD as possible, but if necessary the transmitter may be calibrated in a workshop.

Select '4rtd' from the 'Cond' sub-menu and press *P*. The transmitter will display scrolling decimal points while the reference is being updated followed by 'Ent' prior to returning to the '4rtd' prompt. This completes adjustment of this reference.

6.8.5 Output current reference 'OP'

**Warning: ensure plant safety
before performing this adjustment**

This adjustment is only necessary if the transmitter 4/20mA output current is used. A method of accurately measuring the transmitter output current, such as DVM, is required to calibrate this reference.

Select 'OP' from the 'Cond' sub-menu and press *P*, the transmitter will display 'SurE'. If it is safe to change the transmitter output current between 4 and 20mA continue by pressing *P*. The transmitter will display 'ZEro', pressing *P* again will change the display to '.004A' and the transmitter output current to approximately 4mA. The transmitter output current shown on the external current measuring instrument should be adjusted to $4.000 \pm 0.001\text{mA}$

using the transmitter *Up* and *Down* buttons. When correct press the *E* push-button to return to the 'ZEro' prompt.

To adjust the 20mA output current reference select the 'SPAn' prompt by operating the *Up* or *Down* button. Pressing *P* will change the display to '.020A' and the transmitter output current to approximately 20mA. The transmitter output current shown on the external current measuring instrument should be adjusted to $20.000 \pm 0.001\text{mA}$ using the transmitter *Up* and *Down* buttons. When correct press the *E* push-button twice to return to the 'OP' prompt. This completes adjustment of this reference.

7. TRIM MENU

The Trim Menu is the preferred method of routine calibration. It enables the BA374C transmitter to be adjusted using an external voltage, resistance or temperature calibrator. For maximum accuracy the complete loop including the thermocouple or resistance thermometer may be calibrated by heating or cooling the primary element.

Before using the Trim Menu all the functions in the 'InPut' and 'CAL' sections of the programme menu must be defined, including the 4/20mA output range. For voltage inputs, both the millivoltage input and the corresponding display range must be entered.

If a voltage calibrator is used to simulate a thermocouple the transmitter cold junction compensation must be turned off. Alternatively, the temperature at the BA374C input terminals may be measured and the voltage calibrator corrected for ambient temperature, although this is likely to produce less accurate results.

7.1 Calibration procedure using Trim Menu

The structure of the Trim Menu is shown in Fig 9. Access to the menu is obtained by operating the *P* and *Down* push-buttons simultaneously. If the transmitter is not protected by a security code the first parameter 'ZEro' will be displayed. If the transmitter is protected by a security code, 'COdE' will be displayed first. Pressing *P* again will enable the security code to be entered digit by digit, using the *Up* and *Down* buttons to change the flashing digit, and the *P* push-button to move to the next digit. If the correct code is entered pressing *E* will cause the first parameter 'ZEro' to be displayed. If an incorrect code is entered, or if no button is pressed for ten seconds, the transmitter will automatically return to the display mode.

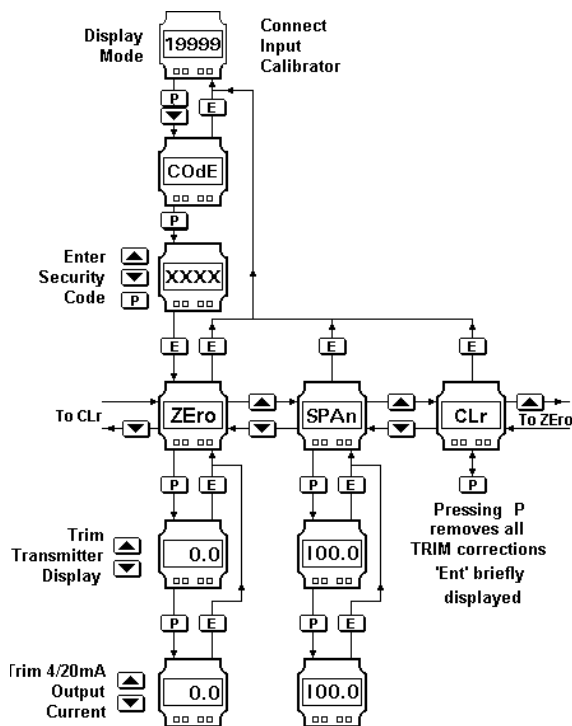

Fig 9 Trim Menu

The 'ZEro' sub-menu allows the transmitter display and output current to be independently trimmed at the bottom of the input range. To make the adjustment connect a calibrator to the transmitter input terminals to simulate minimum input, or place the primary element in a vessel at the minimum temperature. With 'ZEro' displayed, pressing the *P* push-button will cause the temperature display to return. If the display does not correspond with the input calibrator or the temperature of the primary element, operate the *Up* or *Down* button until the transmitter display is correct. Immediately the *Up* or *Down* button is operated the annunciator in the top left hand corner of the display will be activated to warn that any changes in the input signal will be ignored while this display correction is being made.

When the transmitter display is correct, press *P* which will lock the transmitter display and, after briefly displaying 'Ent', allow the 4/20mA output current to be trimmed using the *Up* or *Down* push-button. The output current should be measured with an accurate DVM or another instrument within the loop. Operate the *Up* or *Down* buttons until the required output current is shown on the DVM or other instrument. When correct, press the *E* button to store the trim correction in permanent memory and return the BA374C transmitter to the 'ZEro' prompt. This completes re-calibration of the BA374C transmitter at minimum input.

The transmitter should now be re-calibrated at maximum input by selecting the 'SPAn' sub-menu and adjusting the calibrator to simulate maximum input, or raising the primary element to maximum temperature. With 'SPAn' displayed, pressing the *P* push-button will cause the temperature display to return. If the display does not correspond with the input calibrator or the temperature of the primary element, operate the *Up* or *Down* buttons until the transmitter display is correct. Immediately the *Up* or *Down* button is operated the annunciator in the top left hand corner of the display will be activated to warn that any changes in the input signal will be ignored while this display correction is being made.

When the transmitter display is correct, press *P* which will lock the transmitter display and, after briefly displaying 'Ent', allow the 4/20mA output current to be trimmed using the *Up* or *Down* push-button. Again the output current should be measured with an accurate DVM or another instrument within the loop. Operate the *Up* or *Down* buttons until the required output current is shown on the DVM or other instrument. When correct, press the *E* button to store the trim correction in permanent memory and return the BA374C transmitter to the 'SPAn' prompt. This completes re-calibration of the BA374C transmitter at maximum input.

When calibrating the BA374C using the Trim Menu both the zero and span must be adjusted.

The Trim Menu contains a clear function which enables the small calibration correction made with the 'ZEro' and 'SPAn' sub-menus to be removed. To clear the corrections select 'CLr' from the trim menu and press *P*. The display will show 'Ent' for a short while and then return to the 'CLr' prompt.

7.2 Periodic re-calibration using Trim Menu

The trim menu is the best way of making small calibration adjustments to compensate for any long term drift which may occur. Initially an annual check is recommended to achieve maximum accuracy, although less frequent checks will usually produce acceptable results.

If the BA374C internal references are used to make frequent calibration changes, we recommend that these references should be initially checked once per year as described in section 6.8. If the BA374C is always calibrated with an external reference, such as a voltage source using the trim menu, it will not be necessary to check the internal reference.

8. CALIBRATION EXAMPLE

In this example a BA374C is required to display with maximum resolution the temperature of a type J thermocouple, and to transmit a 4/20mA signal representing -10 to 240°C. If the thermocouple breaks the 4/20mA output current is to rise to full scale. The current security code is 1209.

The example is divided into two sections. Steps 1 to 10 explain how to condition the transmitter and to calibrate the 4/20mA output using the internal references. This will produce acceptable accuracy for most applications, but will not compensate for errors in the thermocouple or load connected to the 4/20mA output. Steps 11 to 13 describe how the Trim Menu may be used to calibrate the complete loop and to compensate for thermocouple errors.

Step 1 Initialisation

When power is applied to the loop the BA374C will automatically perform the initialisation routine described in section 2, and then display and transmit the thermocouple temperature using the existing calibration information.

Step 2 Enter the programme menu

Enter the programme menu by simultaneously pressing the *P* and *E* buttons. The transmitter will respond by displaying 'COdE'. Press *P* to clear this prompt and set the display to the security code 1209 using the *Up*, *Down* and *P* push-buttons. Pressing *E* will enter the code. After a few seconds during which all the decimal points will be activated, the first parameter 'InPut' will be displayed.

Step 3 Define input

With 'InPut' displayed press *P* which will reveal the current transmitter sensor type. Using the *Up* or *Down* button scroll through the menu until thermocouple input 'tHC' is displayed.

Step 4 Define type of thermocouple

With 'tHC' displayed press *P* to enter the thermocouple sub-menu. The first parameter 'tYPE' will be displayed, pressing *P* again will give access to the seven different types of thermocouple. Select 'J' using the *Up* or *Down* button and then press *E* to return to the sub-menu.

Step 5 Define units of display

Using the *Up* or *Down* button select 'dEg', from the sub-menu and press *P* to reveal the current units. Pressing the *Up* or *Down* button will toggle between °C and °F. Select °C and press *E* to return to the sub-menu.

Step 6 Resolution

Using the *Up* or *Down* button select 'rESn' from the sub-menu and press *P*. Pressing the *Up* or *Down* button will toggle between high and low resolution, select 'Hi' and press *E* to return to the sub-menu.

Step 7 Cold junction compensation

In this example only one thermocouple is connected so cold junction compensation is required. Using the *Up* or *Down* button select 'CJC' from the sub-menu and press *P*. The *Up* and *Down* buttons will turn the cold junction 'On' and 'OFF'. Select 'On' and press *E* to return to the sub-menu.

Step 8 Input open circuit drive

Using the *Up* or *Down* button select 'burn' from the sub-menu and press *P* to reveal the current status. Select 'uP' using the *Up* or *Down* button and press *E* three times to return to the 'InPut' prompt via the 'burn' and 'tHC' prompts.

Step 9 Calibrating the 4/20mA output

'CAL' defines the display at which the output current is 4mA and 20mA. Select 'CAL' from the menu using the *Up* or *Down* push-button, and enter the sub-menu by pushing *P*. The transmitter will display a 'ZEro' prompt requesting the display at which the output is to be 4mA. Press *P* and enter -10.0 using the *Up*, *Down* and *P* buttons. Press *E* to return to the 'ZEro' prompt. Select 'SPAn' from the sub-menu and press *P*. Enter 240.0 which is the display at which the output current is to be 20mA and press *E* twice to return to the 'CAL' prompt.

Step 10 Return to the display mode

With the 'CAL' prompt displayed, press *E* to store the conditioning and calibration information and return to the operating mode. All the display decimal points will be activated while the information is being stored. This completes the calibration of the transmitter using the internal references.

The following steps explain how, using the Trim Menu, the BA374C transmitter may be calibrated against an external reference, such as a voltage source or temperature calibrator. Alternatively, the complete loop including the primary element may be calibrated by cooling and heating the thermocouple to -10 and +240°C. This is the preferred method for routine calibration.

Step 11 Entering the trim menu

Enter the trim menu by simultaneously pressing the *P* and *Down* buttons - see Fig 9. The transmitter will respond by displaying 'COdE'. Press *P* to clear this prompt and set the display to the security code 1209 using the *Up*, *Down* and *P* push-buttons. Pressing *E* will enter the code. After a few seconds during which all the decimal points will be activated, the first parameter 'ZEro' will be displayed.

Step 12 Zero adjustment

This adjustment trims the display to read exactly -10.0°C and the output current to be exactly 4.000mA when the type J thermocouple is at -10°C. This can be achieved by cooling the thermocouple to -10°C or by inputting the voltage which the thermocouple should theoretically produce. If a voltage is used the transmitter cold junction compensation (see section 6.3.4) should be turned off during the calibration, or the input voltage should be corrected for ambient temperature, although this may be less accurate.

With the transmitter displaying the 'ZEro' prompt and the correct input connected to the transmitter, push *P* which will cause the transmitter to display the thermocouple temperature. Adjust the display with the *Up* and *Down* buttons until it is -10.0

Note: Immediately the *Up* or *Down* button is operated the annunciator in the top left hand corner of the display will be activated to warn that any

change in the input signal will be ignored while this display correction is being made.

Operating the *P* push-button will lock the transmitter display at -10.0 and allow the output current to be trimmed using the *Up* or *Down* button. When the output current measured by a DVM is 4.000mA, the *E* push-button should be operated to return the transmitter to the 'ZEro' prompt.

This completes calibration at -10.0°C.

Step 13 Span adjustment

With the transmitter displaying the 'ZEro' prompt select 'SPAN' by pressing the *Up* or *Down* button. With the thermocouple heated to 240°C, or an equivalent voltage input, push *P* which will cause the transmitter to display the thermocouple temperature. Adjust the display with the *Up* and *Down* buttons until it is 240.0

Note: Immediately the *Up* or *Down* button is operated the annunciator in the top left hand corner of the display will be activated to warn that any change in the input signal will be ignored while this display correction is being made.

Operating the *P* push-button will lock the transmitter display at 240.0 and allow the output current to be trimmed using the *Up* or *Down* button. When the output current measured by a DVM is 20.000mA, the *E* push-button should be operated to return the transmitter to the 'SPAN' prompt.

This completes calibration at 240.0°C. Pressing the *E* push-button again will return the transmitter to the display mode.

9. MAINTENANCE

The instrument should only be maintained by trained competent personnel.

9.1 Fault finding during commissioning

If the BA374C transmitter fails to function during commissioning the following procedure should be followed:

Symptom	Cause	Solution
No display or output current	Incorrect power supply	Check wiring or no and power supply polarity Check that voltage between terminals 5 & 6 is between 10 and 30V with terminal 5 positive.
BA374C displays 1	Positive display over-range	The transmitter input exceeds the upper operating range of the selected THC or RTD. For voltage inputs, display is incorrectly calibrated. Check calibration.
BA374C displays -1	Negative display over-range	The transmitter input is less than the lower operating range of the selected THC or RTD. For voltage inputs, display is incorrectly calibrated. Check calibration.
Output fixed below 4mA or above 20mA.	4/20mA output current over, or under-range	The transmitter output current is incorrectly calibrated. Check calibration.

9.2 Fault finding after commissioning

ENSURE PLANT SAFETY BEFORE STARTING MAINTENANCE

Live maintenance is permitted on intrinsically safe equipment installed in a hazardous area, but only certified test equipment should be used unless a gas clearance certificate is available.

If a BA374C fails after it has been functioning correctly the procedure shown in section 9.1 should be followed.

9.3 Servicing

The BA374C cannot be serviced on-site. Electronic assemblies may be exchanged between enclosures, but sub-boards must not be interchanged between electronic assemblies. All BA374C transmitter functions are easily programmable on-site, a single spare transmitter or electronic assembly may therefore be used to replace any instrument which fails.

Suspect instruments should be returned to BEKA associates or to our agent in your area.

9.4 Routine maintenance

The mechanical condition of the instrument and electrical calibration (see section 7.2) should be regularly checked. The interval between inspections depends upon environmental conditions. We recommend that initially this is performed annually.

9.5 Guarantee

Transmitters which fail within the guarantee period should be returned to BEKA associates or our local agent. It is helpful if a brief description of the fault symptoms and a list of error messages is provided.

9.6 Customer comments

BEKA associates is always pleased to receive comments from customers about our products and services. All communications are acknowledged and whenever possible, suggestions are implemented.

ACCESSORIES

10. IDENTIFICATION AND MOUNTING

10.1 Engraved scale and tag plates

All BA374C indicators are fitted with blank stainless steel scale and tag plates above and below the display. These can easily be removed for engraving, or if requested they can be supplied engraved with any units of measurement and tag information. Each plate can accommodate:

1 row of 9 alphanumeric characters 10mm high

or 1 row of 13 alphanumeric characters 7mm high

or 2 rows of 18 alphanumeric characters 5mm high

10.2 Pipe mounting kits

Two pipe mounting kits are available for securing the BA374C to a horizontal or vertical pipe.

BA392 Stainless steel bracket secured by two worm drive hose clips. Will clamp to any vertical or horizontal pipe with outside diameter between 60 to 80mm.

BA393 Heavy duty stainless steel bracket secured by a single 'V' bolt. Will clamp to any vertical or horizontal pipe with an outside diameter between 40 and 80mm.

10.3 Panel mounting kit

The BA394 panel mounting kit will secure the BA374C indicator into a panel aperture. All parts are stainless steel and the kit contains a trim-plate to conceal the edge of the panel aperture.

11.0 ALARMS

The BA374C can be supplied with two solid state single pole alarm outputs. Each output may be programmed as a high or low alarm with a normally open or a normally closed output. Fig 10 illustrates the conditions available and shows which are fail safe, i.e. output is in the alarm condition (open) when the transmitter is not powered. When an alarm is activated the indicator display alternates between the measured value and an alarm identification.

WARNING!

These alarm outputs should not be used for critical safety applications such as a shut-down system.

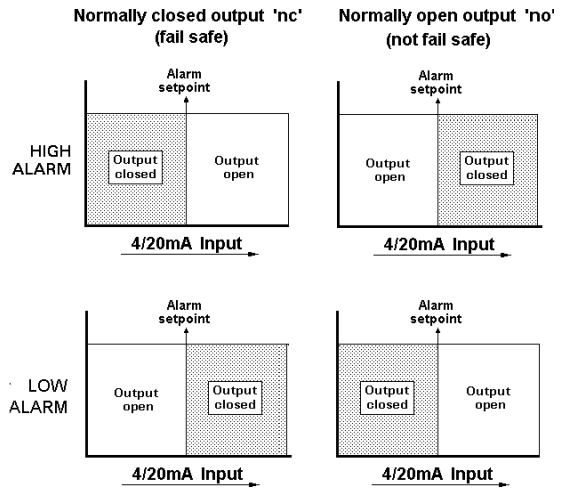

Fig 10 Alarm outputs

Programmable functions for each alarm include adjustable hysteresis, alarm delay and alarm accept.

11.1.1 Solid state output

Each alarm has a galvanically isolated single pole solid state switch output as shown in Fig 11. The output is polarised and current will only flow in one direction.

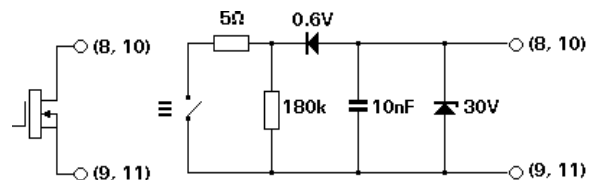

Fig 11 Equivalent circuit of each alarm output

11.1.2 Intrinsic safety

Each alarm output is a separate galvanically isolated solid state switch with certified output parameters less than those specified for *simple apparatus* in Clause 5.4 of EN50020. This allows the alarm terminals 8 & 9 and 10 & 11 to be connected to any intrinsically safe circuit protected by a EEx ia IIC certified Zener barrier or galvanic isolator providing the output parameters of the circuit do not exceed:

$$\begin{aligned}
 U_o &= 30V \text{ dc} \\
 I_o &= 280mA \\
 P_o &= 0.85W
 \end{aligned}$$

The maximum equivalent capacitance and inductance between each set of alarm terminals is:

$$\begin{aligned} C_{eq} &= 20\text{nF} \\ L_{eq} &= 10\mu\text{H} \end{aligned}$$

These figures must be subtracted from the maximum permitted cable capacitance and inductance specified by the system certificate of the circuit connected to the alarm.

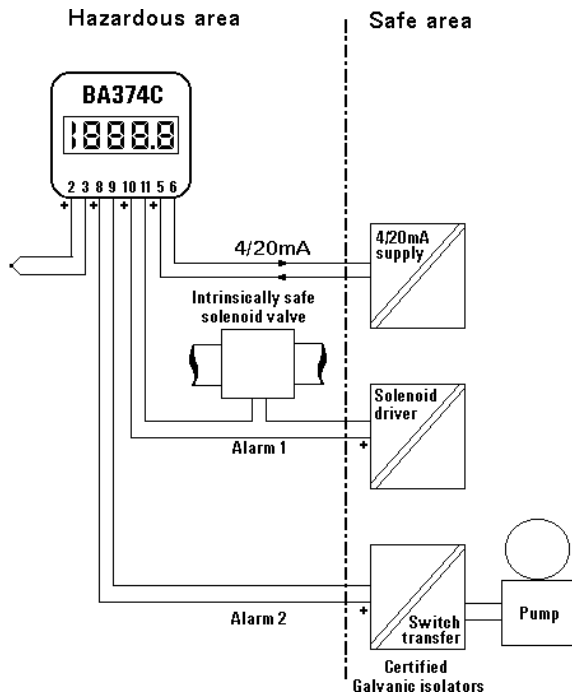

Fig 12 Typical application of alarms

11.1.3 Programming & adjustment

When an alarm card is added to a BA374C transmitter the Programme Menu is extended as shown in Fig 13. The additional functions 'ALr1', 'ALr2' and 'AcSP' appear between 'Cond' and 'COde' in the programme menu. For simplicity Fig 13 only shows the functions available on alarm 1, but alarm 2 has identical facilities.

The alarms relate to the digital display and the setpoints are shown in the same units as the display.

The following table summaries each of the alarm programme functions and includes a cross reference to more detailed information. Again only the functions on alarm 1 are listed, but alarm 2 has identical facilities.

11.2 Summary of programmable alarm functions.

Display	Summary of function
'EnbL'	Alarm enable Enables or disables the alarm function without changing the alarm parameters. See section 11.3.1
'SP1'	Alarm setpoint 1 Adjusts the alarm setpoint. The alarm is activated when the indicator display equals the setpoint. The setpoint can also be adjusted directly from the operating mode. See section 11.3.2
'HI.LO'	Alarm function Defines whether the alarm has a high or low function. See section 11.3.3
'no.nc'	Normally open or normally closed output Determines whether the single pole alarm output is open or closed in the alarm condition. See section 11.3.4
'HStr'	Hysteresis Adjusts the alarm hysteresis. See section 11.3.5
'dELA'	Alarm delay time Adjusts the delay between the display equalling the setpoint and the alarm output being activated. See section 11.3.6
'SIL'	Alarm silence time Defines the time that the alarm output remains in the non-alarm condition following acceptance of an alarm. See section 11.3.7
'AcSP'	Access setpoint Sub-menu which enables the function allowing direct access to the alarm setpoints from the operating mode, and defines a separate security code. See section 11.3.8

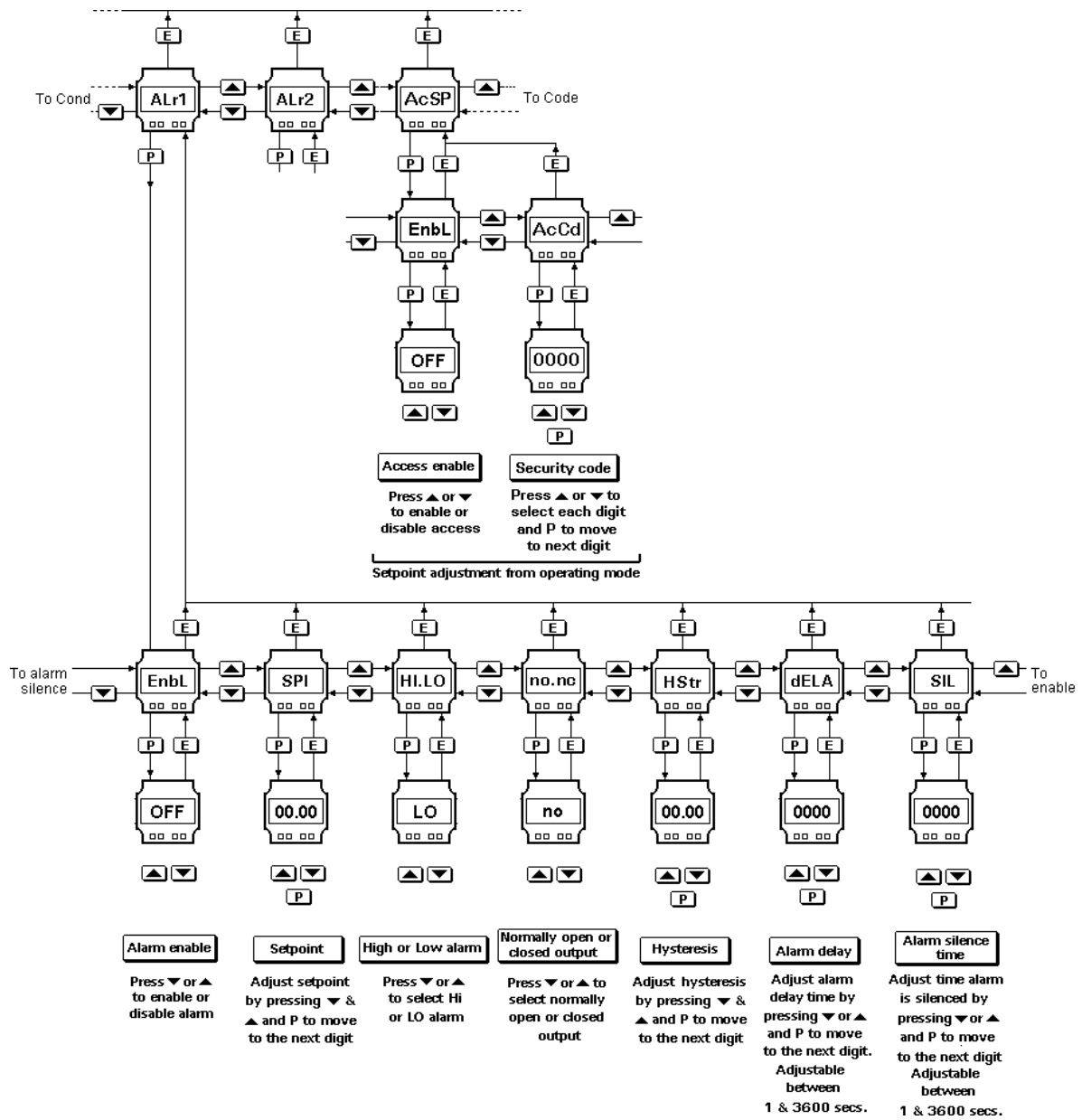

Fig 13 Programme structure for optional alarms

11.3 Description of programmable functions

The following sections contain detailed descriptions of each programmable function. They should be read in conjunction with the programme structure shown in Fig 13.

11.3.1 Alarm enable: EnbL

This function allows the alarm to be enabled or disabled without altering any of the alarm parameters. To check or change the function select 'EnbL' from the alarm sub-menu and press *P* which will reveal the current setting. The function can be changed by pressing the *Up* or *Down* button followed by the *E* button to return to the 'EnbL' prompt.

11.3.2 Setpoint adjustment: SP1 and SP2

The setpoint of each alarm relates to the transmitter display and each may be independently positioned anywhere in the transmitter display range. When positioned close to the display limits, care should be taken to ensure that hysteresis does not place the alarm beyond the display limits.

To adjust the setpoint select 'SP1' or 'SP2' from the alarm sub-menu and press *P* which will reveal the existing alarm setpoint. Each digit of the setpoint can be adjusted using the *Up* and *Down* push-buttons, and the *P* button to move to the next digit. When the required setpoint has been entered press *E* to return the setpoint prompt 'SP1' or 'SP2'.

11.3.3 Alarm function: HI.LO

Each alarm can be conditioned as a high or low alarm. To check or change the alarm function select 'HI.LO' from the alarm sub-menu and press *P* to reveal the current setting. The function can be changed by pressing the *Up* or *Down* buttons followed by the *E* button to return the 'HI.LO' prompt.

11.3.4 Alarm output status: no.nc

This function allows the alarm output to be open or to be closed in the alarm condition. When deciding which is required, care must be taken to ensure that the alarm output is fail safe. See Fig 13.

WARNING!

When the transmitter supply is removed both alarm outputs will open irrespective of conditioning. Therefore for fail safe operation both alarm outputs should be programmed to be open in the alarm condition.

To check or change the alarm output status select 'no.nc' from the alarm sub-menu and press *P* reveal the current setting. The function can be changed by pressing the *Up* or *Down* button followed by the *E* button to return the 'no.nc' prompt.

11.3.5 Hysteresis: HStr

To adjust the hysteresis select 'HStr' from the alarm sub-menu and press *P* which will reveal the existing figure. Each digit can be adjusted using the *Up* and *Down* push-buttons, and the *P* button to move to the next digit. When the required hysteresis has been entered press *E* to return the 'HStr' prompt.

e.g. A transmitter with a high alarm set at 240 and hysteresis of 10 will perform as follows:

High alarm will be activated when display equals or exceeds 240, but will not reset until the display falls below 230.

11.3.6 Alarm delay: dELA

This function enables activation of the alarm output to be delayed for a fixed time following the alarm condition occurring. The delay can be programmed in 1 second increments up to 3600 seconds. If a delay is not required zero should be entered. To adjust the delay select 'dELA' from the alarm sub-menu and press *P* which will reveal the existing delay. Each digit of the delay can be adjusted using the *Up* and *Down* push-buttons, and the *P* button to move to the next digit. When the required delay has been entered press *E* to return the 'dELA' prompt.

11.3.7 Alarm silence time: SIL

This function is primarily intended for use in small installations where the alarm output directly operates an annunciator such as a sounder. When the alarm silence time is set to any figure other than zero, the *P* push-button becomes an alarm accept button. After an alarm has occurred, operating the *P* button will cause the alarm output to revert to the non-alarm condition for the programmed alarm silence time. The display will continue to indicate an alarm after it has been accepted and silenced. The alarm silence time may be adjusted between 0 and 3600 seconds in 1 second increments.

To adjust the alarm silence time select 'SIL' from the alarm sub-menu and press *P* which will reveal the existing time. Each digit can be adjusted using the *Up* and *Down* push-buttons, and the *P* button to move to the next digit. When the required time has been entered press *E* to return the 'SIL' prompt.

11.3.8 Access Setpoint: AcSP

This function controls the parameters in a separate menu which provides direct access to the alarm setpoints when the transmitter is in the display mode i.e. when it is displaying temperature. See section 11.4 for a full description. This menu allows an operator to adjust the two alarm setpoints without having access to the Programme, Trim or Alarm Menus. A separate security code may be defined to prevent unauthorised access.

This separate direct access menu is enabled and a separate security code entered from the 'AcSP' function in the Programme Menu - see Fig 13. To change the menu parameters select 'AcSP' from the Programme Menu and press *P* which will display the enable prompt 'EnbL'. Press *P* again to reveal if the direct access menu is 'On' or 'OFF'. The *Up* or *Down* buttons will toggle the display between the two conditions.

If 'OFF' is selected, the operator will not have access to the setpoints from the display mode. Return to the 'AcSP' prompt in the main menu by pressing *E* twice.

If 'On' is selected, the operator will have direct access to the alarm setpoints from the display mode via a separate optional security code. To define the four digit numerical code press *P* to return to the 'EnbL' prompt followed by the *Up* or *Down* button to select the access code prompt 'AcCd'. Pressing *P* will reveal the current security code. Each digit of the code may be changed by operating the *Up* and *Down* push-buttons, and the *P* button to move to the next digit. When the required code has been entered, press *E* twice to return to the 'AcSP' prompt in the Programme Menu.

Code 0000 will disable the security code allowing direct access to the setpoints by pressing the *P* and *Up* buttons simultaneously.

New instruments are supplied with this function disabled and the security code set to 0000

11.4 Adjusting the alarm setpoints from the display mode.

Access to the alarm setpoint when the BA374C transmitter is in the display mode is obtained by operating the *P* and *Up* push-buttons simultaneously - see Fig 14. If the setpoints are not protected by a security code the alarm setpoint one 'SP1' will be displayed. If the setpoints are protected by a security code, 'COdE' will be displayed first. Pressing *P* again will enable the alarm security code to be entered digit by digit using the *Up* and *Down* buttons to change the flashing digit, and the *P* push-button to move to

the next digit. If the correct code is entered pressing *E* will cause alarm setpoint one 'SP1' to be displayed. Pressing the *Up* or *Down* button will toggle the display between 'SP1' and 'SP2'.

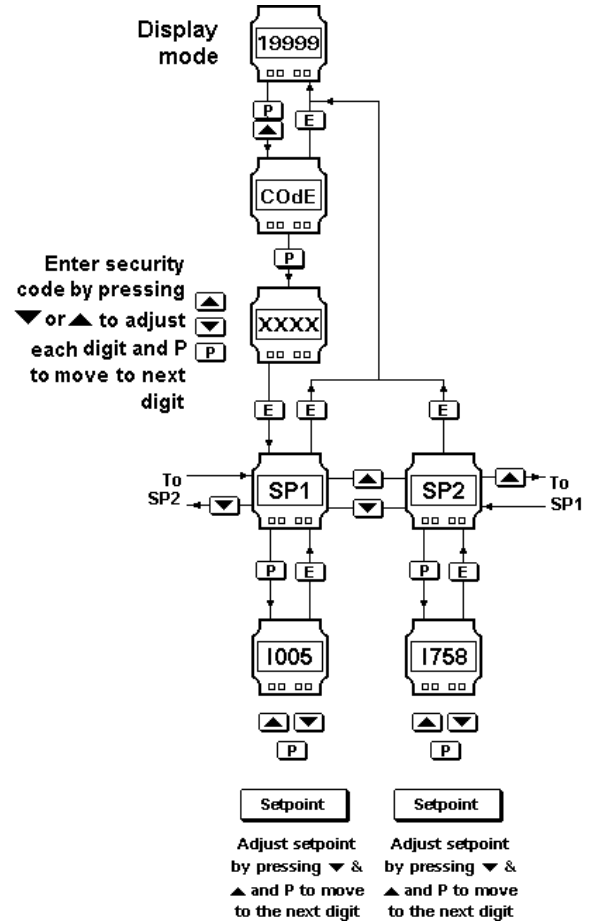

Fig 14 Setpoint adjustment from display mode

If an incorrect code is entered, or a button is not pressed for ten seconds, the transmitter will automatically return to the display mode.

To adjust an alarm setpoint select 'SP1' or 'SP2' and press *P* which will reveal the current setting. Each digit of the setpoint may be adjusted using the *Up* and *Down* push-buttons, and the *P* button to move to the next digit. When the required setpoint has been entered, pressing *E* will return the display to the 'SP1' or 'SP2' prompt from which the other setpoint may be selected, or the transmitter may be returned to the display mode by pressing *E* again. Direct access to the alarm setpoints is only available when the menu is enabled - see section 11.3.8

12. BACKLIGHT

The BA374C can be supplied with LED backlighting to improve display contrast when the transmitter is installed in a poorly illuminated area. The backlight is segregated from the measuring circuit and has been certified as a separate intrinsically safe circuit.

The backlight must be powered from the safe area via a Zener barrier or a galvanic isolator as shown in Fig 15. Any EEx ia IIC certified Zener barrier or galvanic isolator may be used, providing the output parameters do not exceed:

U_o	=	30V dc
I_o	=	159mA
P_o	=	0.8W

For guidance the system certificates list some of the devices which may be used.

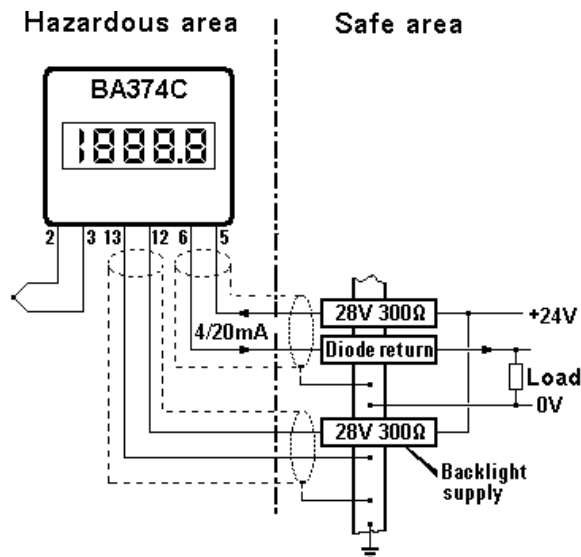

Fig 15 Backlight power supply

The display brilliance depends upon the current flowing through the backlight which is determined by the supply voltage and the end-to-end resistance of the Zener barrier or output resistance of the galvanic isolator. Brilliance will not be significantly reduced until the current falls below 20mA.

$$\text{Backlight current} = \frac{V_{\text{supply}} - 18}{\text{End-to-end resistance of barrier}\#}$$

or output resistance of galvanic isolator