

**BEKA** associates



BA304N and BA314N  
Type N  
2-wire 4/20mA  
digital indicators

***Instruction manual***

# **CONTENTS**

## **1 Description**

## **2 Operation**

## **3 Application**

3.1 Electrical system design

## **4 Installation**

4.1 Mounting

4.2 Installation procedure

## **5 Calibration**

5.1 Calibration controls

5.2 Example of how to calibrate a linear indicator

5.3 The BA314N square root-extractor

5.4 Example of how to calibrate the BA314N with square root-extraction

5.5 Over and under-range

## **6 Maintenance**

6.1 Fault finding during commissioning

6.2 Fault finding after commissioning

6.3 Inspection

6.4 Servicing

6.5 Warranty

## **7 Accessories**

7.1 Engraved scale plate

7.2 Engraved tagging plate

7.3 Pipe mounting kit

## **8 Customer comments**

**Appendix 1** BASEEFA certificates

**Appendix 2** Product Specification

## 1 Description

The BA304N and BA314N are robust 2-wire field mounting digital indicators certified Ex N for use in Zone 2 without barriers.

Model	Display mode	Display height
BA304N	linear	25mm
BA314N	root-extracting or linear	25mm

Both indicators are loop powered from the live-zero signal, but only introduce a 1.1V drop which allows them to be installed into almost any 4/20mA current loop. No additional power supply or battery is required.

The main application of the BA304N is to display a linear measured variable or control signal in the process area. The span and zero of the instrument are independently adjustable so that the indicator can be calibrated to display any linear variable represented by the 4/20mA signal; for example temperature, pressure, level or actuator position.

The BA314N incorporates a square root-extractor to linearise the output of 4/20mA flow transmitters which have a square law characteristic e.g. those operating from an orifice plate or venturi tube. The indicator can therefore display a flow signal in linear engineering units. The BA314N can also display linear 4/20mA signals.

## 2 Operation

Apart from the inclusion of a square root-extractor, the BA304N and BA314N are electrically identical. The indicators are 2-wire devices which are powered by the current they are measuring, and therefore they do not require an additional power supply or batteries. Both indicators may be considered, and used, in the same way as conventional moving coil analogue meters.

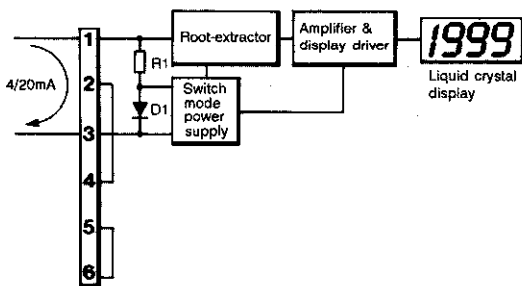

Figure 1 Simplified block diagram of BA300N series indicators

The 4/20mA current flows through resistor R1 and forward biased diode D1. The voltage developed across D1 is multiplied by the switch mode power supply and used to power the amplifiers, square root-extractor when fitted, and the liquid crystal display. The voltage developed across R1, which is proportional to the 4/20mA input current, provides the input signal to the display amplifier. Low power MOS semiconductors are used throughout the indicator. The total power consumption is less than 3 milliwatts, which enables the voltage drop introduced into the 4/20mA loop to be less than 1.1V.

## 3 Application

The BA304N & BA314N indicators will operate in series with any 4/20mA current loop, providing that the loop can tolerate the additional 1.1V drop introduced by the indicator.

A BA304N should be used when the 4/20mA signal represents a linear variable, and a BA314N when the 4/20mA signal is from a non linearised flow transmitter. The BA314N can also be used with linear signals by switching off the square root extractor.

### 3.1 Electrical System Design

The BA300N series indicator is connected in series with the 4/20mA current loop and introduces a voltage drop of less than 1.1V at 20mA. When designing a loop it is therefore necessary to add this voltage to the other voltage drops caused by transmitters and loads, and to ensure that the sum of all the voltage drops is less than the minimum power supply voltage. Figure 2 shows a process loop where a 2-wire transmitter is driving a controller.

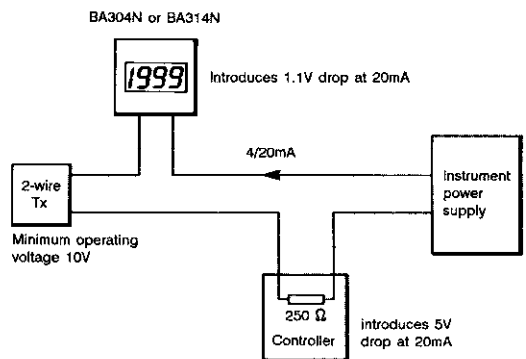

Figure 2 BA300N series indicator providing indication in a control loop

Considering the total voltage drop around the loop:

Minimum operating voltage of 2-wire Tx	10.0V
Maximum voltage drop caused by controller	5.0V
Maximum voltage drop caused by indicator	1.1V
Maximum voltage drop caused by cable resistance	0.4V
	16.5V

The instrument power supply must therefore have a minimum output voltage at 20mA of greater than 16.5V.

The BA300N series indicator may also be driven directly from any instrument with a 4/20mA output to provide a remote indication. Figure 3 shows an indicator connected to the auxiliary 4/20mA output of a gas analyser. Again, it is only necessary to ensure that the voltage capability of the auxiliary 4/20mA output is greater than the voltage drop of the indicator plus any voltage drops caused by cable resistances.

The BA300N series indicators incorporate protective components to prevent damage by non-repetitive transient currents of up to 30A for 15mS. However, when connected to long overhead or underground cables, it may be necessary to install a surge protection unit close to the indicator, if it is considered that the cable is likely to be subjected to high transient currents from lightning or electrical switch gear.

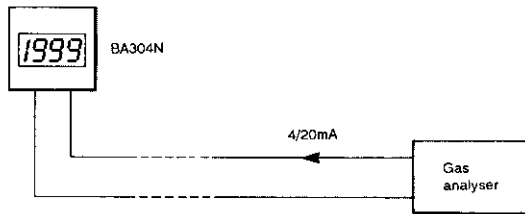

Figure 3 BA300N series indicator providing remote indication of gas analyser output

### 3.2 Explanation of Type N certification

Type N apparatus is specifically designed for installation in Zone 2, it is non-incendive in normal operation and is unlikely to develop a fault which could cause ignition.

The BA304N and BA314N digital indicators have been certified Ex N by BASEEFA to BS4683: Part 3:1972. This instruction manual describes installations which conform with the UK Code of Practice BS5345:Part 7:1979. When designing systems for installation outside the UK, the local code of practice should always be consulted.

A reduced copy of the BASEEFA certificate for the BA304N and BA314N is included as Appendix 1 of this manual, full size copies are available from BEKA Associates.

The BA304N and BA314N have been certified Ex N II T6, which means that when connected to a suitable system, they may be installed in:

Zone 2 An explosive gas-air mixture not likely to occur in normal operation, and if it does will only exist for a short time

May be used with above ground (group II) gases or vapours in gas groups:

Group IIA	Propane
Group IIB	Ethylene
Group IIC	Hydrogen

Having a temperature classification of:

T1	450°C
T2	300°C
T3	200°C
T4	135°C
T5	100°C
T6	85°C

This means that the BA304N and BA314N may be installed in Zone 2 and used with all industrial gases.

## 4 Installation

### 4.1 Mounting

The BA304N and BA314N 4/20mA digital indicators are housed in either an epoxy painted die-cast aluminium enclosure, or a glass reinforced polyester (GRP) enclosure. To simplify installation, the field wiring terminals are located in the enclosure so that it can be installed and wired without the indicator in place. The enclosure also contains a 3.3V Zener diode to maintain the continuity of the 4/20mA loop when the indicator is not fitted. A simplified diagram of the indicator and enclosure is shown in Figure 4.

The enclosure can be directly mounted onto any flat surface using the four corner 'D' holes, or can be clamped to pipework using the accessory pipe mounting kit. Whichever technique is used, it is important to choose a location which ensures that the indicator always remains within the environmental limits shown in the specification, and that the display window is not exposed to continuous direct sunlight.

When correctly installed, the enclosure will provide IP65 (noseproof) protection. However, when the BA304N or BA314N are mounted outside, it is recommended that a hood or flexible transparent cover be provided to prevent standing water accumulating on the gasket and display window.

**When installed in Zone 2, both the BA304N and the BA314N indicators must be fitted with Ex N or EEx e approved cable glands and blanking plugs.**

### 4.2 Installation procedure

- i Remove the enclosure cover by unscrewing the four captive 'A' screws.
- ii Remove the indicator from the enclosure by unscrewing the three captive 'B' screws and carefully lifting the assembly from the enclosure.
- iii Remove the terminal cover from the enclosure by unscrewing the two captive 'C' screws.
- iv Mount the enclosure on a flat surface and secure with screws or bolts through the four corner 'D' holes. Alternatively, assemble the pipe mounting kit which is supplied with its own instruction sheet.

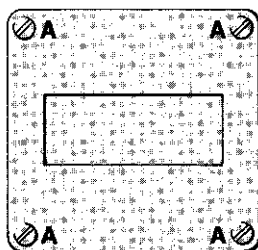

**Step 1** - Remove the enclosure cover by unscrewing the four 'A' screws.

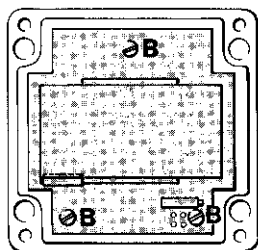

**Step 2** - Remove the indicator from the enclosure by unscrewing the three captive 'B' screws.

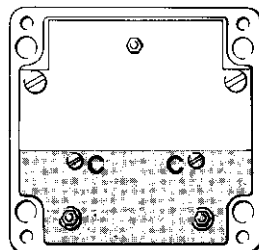

**Step 3** - Remove the terminal cover from the enclosure by unscrewing the two captive 'C' screws.

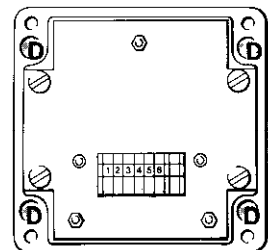

**Step 4** - Mount the enclosure on a flat surface and secure with screws or bolts through the four corner 'D' holes. Alternatively, assemble the pipe mounting kit which is supplied with its own instruction sheet.

Figure 4 Simplified view of BA300N series field mounting indicator showing assembly sequence

- v Fit cable glands or conduit fitting into the two M20x1.5 holes at the bottom of the enclosure, ensure that the screw threads do not protrude too far into the terminal compartment.
- vi Connect the field wiring to the terminals as shown in Figure 5. The version in an aluminium enclosure is provided with an earth terminal which is internally connected to the enclosure die-casting. This terminal should be connected to a local earthing point to ensure personnel safety. The glass reinforced polyester (GRP) version has a non-conductive enclosure and a local earth connection is therefore not required. In this version the terminal at the right hand side of the seven way terminal block is fitted with a blank identification tag and should not be used.
- vii Replace terminal cover and tighten the two 'C' screws.
- viii Replace the indicator in the enclosure and evenly tighten the three 'B' screws.
- ix Replace the enclosure cover and evenly tighten the four 'A' screws.

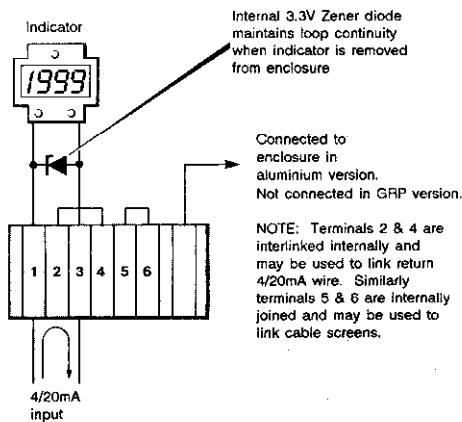

Figure 5 Terminal connections

## 5 Calibration

BA300N series field mounting digital indicators are supplied calibrated as specified at time of ordering. If calibration is not requested, the indicator will be set to display 00.0 at 4mA and 100.0 at 20mA. The BA314N which incorporates a square root-extractor, will be set for linear operation unless otherwise specified at time of ordering.

### 5.1 Calibration Controls

The location of all calibration controls and links are shown in Figure 6. The BA304N and BA314N use the same printed circuit board. The BA314N incorporates a square root-extractor which is located on a small plug in sub-board.

#### Zero Adjustment

Zero is defined as the figure displayed by the indicator with a 4.000mA input current. The zero may be adjusted to any figure between -1000 and 1000. The position of the suppression/elevation links determines whether a positive or negative number is displayed, and the zero potentiometer sets the exact figure displayed.

With the suppression/elevation links in the suppression position, and a 4mA input, the indicator can be adjusted to display any number between -1000 and 000. With the suppression/elevation links in the elevation position, the indicator can be adjusted to display any figure between 000 and 1000 with a 4mA input.

The zero potentiometer has two ranges. With the zero link in position 'D' the zero potentiometer will adjust the figure displayed by the indicator with a 4mA input current between 000 and 500. With the zero link in position 'C' the potentiometer will adjust the zero between 500 and 1000.

Zero suppression or elevation may not be used with the BA314N when operating in the square root-extracting mode, see section 5.3

#### Span Adjustment

Span is defined as the difference between the number displayed with a 4.000mA input and the number displayed with a 20.000mA input. The span may be adjusted to any figure between 000 and 2000.

The span potentiometer has four equal ranges which are selected by the position of links E, F, G and H - see Figure 6.

#### Decimal Point

The position, or absence, of the displayed decimal point, is defined by the position of the decimal point selection link see Figure 6.

#### Function Link

The BA304N and the BA314N have a function link to select linear or square root-extracting operation. On the BA304N, which is not fitted with the root-extracting sub-board, this link must always be in the linear position.

All the calibration links should be extracted and inserted with a pair of long nosed pliers, taking care not to damage nearby components.

### 5.2 Example of how to calibrate a linear indicator

This example shows how to calibrate an indicator for use with a 4/20mA signal representing a linear variable. It applies to the BA304N and to the BA314N when set for linear operation.

The indicator is required to display:

25.0 with a 4.000mA input  
and 180.0 with a 20.000mA input

i.e. A zero of 250 positive } ignoring the  
A span of 1550 } decimal point  
A decimal point before the least significant digit

The following adjustments are required:

*Step 1 The indicator is required to display a positive zero therefore the suppression/elevation links should be put in the elevation position.*

*Step 2 The required zero is 250, therefore the zero link should be put into the 'D' position.*

*Step 3 The required span is 1550, therefore the spans link should be put into the 'E' and 'F' positions.*

*Step 4 The decimal point is required before the least significant digit, therefore the decimal point selection link should be put in position 'L'.*

*Step 5 With 4.000mA input current adjust the zero potentiometer until the indicator displays 25.0*

*Step 6 With 20.000mA input current adjust the span potentiometer until the indicator displays 180.0*

Step 7 Repeat Steps 5 & 6 until both calibration points are correct. The span and zero controls are almost independent, it should therefore only be necessary to repeat each adjustment two or three times.

### 5.3 The BA314N Square Root-Extractor

The BA314N incorporates an accurate square root-extractor which enables the indicator to display a flow signal in linear engineering units. The root-extractor provides linearisation of the flow signal between 4.16mA and 20mA, so the indicator will accurately display the flow in linear units between 10% and 100% of full flow. The linearisation continues to operate with slightly reduced accuracy down to 2.5% of maximum flow, below this level the display is clamped at zero within  $\pm 10$  digits.

Most flowmeters and the square root-extractor in the indicator do not operate with maximum accuracy at low flows, i.e. below 10% of maximum flow (4.16mA). The indicator zero control should therefore be adjusted to give the required display at 4.16mA, which corresponds to 10% of maximum flow. **The zero control should not be adjusted to give a zero display at 4mA.**

For reference, the following table shows the output current from a non linearised flowmeter at various flows.

% of full flow	Current output mA
2.5%	4.01mA
10%	4.16mA
25%	5.00mA
50%	8.00mA
75%	13.00mA
100%	20.00mA

The square root-extractor within the BA314N indicator will only provide accurate linearisation of flow signals if 4mA corresponds to zero flow. An elevated or suppressed display zero may therefore not be used with the BA314N when operating in the root-extracting mode.

### 5.4 Example of how to calibrate the BA314N with square root-extraction

The BA314N indicator operating in the square root-extracting mode is required to display the output from a flowmeter with a 20mA output corresponding to 140 gallons per minute.

The BA314N is required to display:

Flow gallons/ min	% of full flow	Current mA	Indicator display
14	10%	4.160mA	14.0
35	25%	5.000mA	35.0
70	50%	8.000mA	70.0
105	75%	13.000mA	105.0
140	100%	20.000mA	140.0

The following adjustments are required:

Step 1 The BA314N may not have zero suppression or elevation when used in the square root-extracting mode. For this mode the zero suppression/elevation links should always be put in the elevation position, and the zero link in position 'D'.

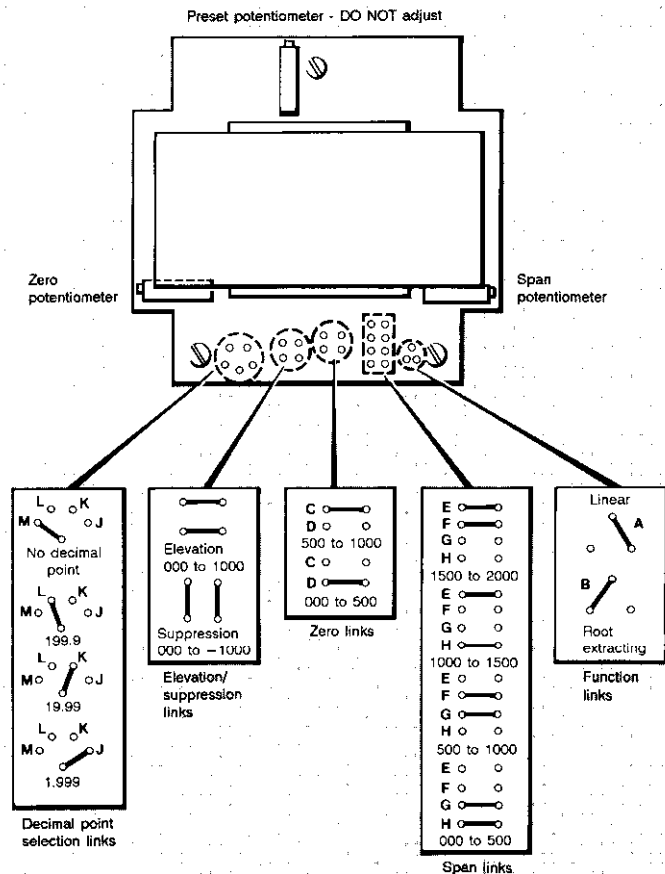

Figure 6 Location of calibration controls and links

- Step 2** The required span is 1400 ignoring position of decimal point, therefore the span links should be put into the 'E' and 'H' positions.
- Step 3** The decimal point is required before the least significant digit, therefore, the decimal point selection link should be put into position 'L'.
- Step 4** With 4.16mA input adjust the zero control until the indicator displays 14.0.
- Step 5** With 20.000mA input adjust the span control until the indicator displays 140.0
- Step 6** Repeat Steps 4 & 5 until both calibration points are correct.

Indicator displays -1	Negative over-range	The indicator has been incorrectly calibrated & is trying to display a number less than -1999
Unstable display. More than ±1 digit of jitter	4/20mA input current contains large ripple current	Reduce ripple content
	Insufficient voltage to operate indicator i.e. less than 1.1V	Check supply voltage & voltage drops caused by all components within the loop

### 5.5 Over and Under-range

If the display range of the BA300N series indicator is exceeded i.e. below -1999 or above 1999, the three least significant digits will automatically be blanked. Under-range is therefore indicated by a -1 display and over-range by a 1 display.

If the display range is not exceeded, the BA304N and BA314N indicators operating in the linear mode, will produce accurate results outside the normal 4/20mA input current range. Although not guaranteed, most BA300N series indicators will operate from 3.5 to 25mA in the linear mode.

## 6 Maintenance

### 6.1 Fault Finding During Commissioning

If an indicator fails to function during commissioning the following procedure should be used:

Symptom	Cause	Solution
No display	Incorrect wiring to indicator	Correct wiring error, indicator will not be damaged by reversed connections
	Indicator not correctly installed in enclosure	Check that the three 'B'screws are tight but do not over-tighten. Ensure that connecting surfaces are clean <i>Note: The voltage drop caused by the enclosure is about 3.5V without the indicator. This falls to 1V with the indicator correctly installed in the enclosure</i>
Indicator displays 1	Positive over-range	The indicator has been incorrectly calibrated & is trying to display a number greater than 1999

### 6.2 Fault Finding after Commissioning

#### ENSURE PLANT SAFETY BEFORE STARTING MAINTENANCE

**Live maintenance of Type N approved BA304N and BA314N indicators installed in Zone 2 is restricted to recalibration. This permits the adjustment of the potentiometers and repositioning of the links; all further maintenance must be done with the power isolated. All maintenance work must comply with the requirements of BS5345:Part 7:1979.**

If an indicator fails after it has been operating correctly, the following procedure should be used:

Symptom	Cause	Solution
No display, no voltage across terminals	Short or open circuit in wiring, or fault in indicator	Check all wiring
No display, between 3 & 4V across terminals	Indicator not correctly installed in enclosure	Remove indicator from enclosure, clean connecting surfaces on pillars & indicator. Replace indicator & tighten the three 'B'screws. Do not overtighten.
Unstable display More than ±1 digit of jitter	4/20mA current has developed large ripple component	Find source of ripple
	Insufficient voltage to operate indicator i.e. less than 1.1V	Check supply voltage & voltage drops caused by all components within the loop

If the above procedure does not reveal the cause of the fault, it is recommended that the indicator is removed from the enclosure, and replaced with another unit. If the second unit functions correctly, the fault is within the original indicator. If the BA304N or BA314N is still faulty, it is likely that the fault is within the enclosure assembly.

### **6.3 Inspection**

When a BA304N or BA314N indicator is installed in Zone 2 there must be an initial inspection followed by periodic inspections at intervals not exceeding two years, as defined in Table 1 of the Code of Practice BS5345:Part 7:1979.

Following any repair, adjustment or modification, those parts which have been disturbed must also be inspected as defined in Table 1 of the Code of Practice.

### **6.4 Servicing**

BA300N series indicators have been designed so that they can easily be replaced without disturbing the field wiring. All BA300N series indicators can be calibrated on site, so a single spare instrument is able to replace any indicator which fails. A BA314N will operate in the linear or square root-extracting mode and may therefore be used to replace either a BA304N or BA314N. BEKA Associates and most distributors maintain a stock of indicators which are available on short delivery if a customer is unable to justify purchasing a spare.

BEKA Associates recommend that, except under exceptional circumstances, faulty indicators are returned to the factory or local agent for repair. However, if this is not possible BEKA Associates will provide service information for the instrument.

### **6.5 Warranty**

Indicators which fail within the warranty period should be returned to BEKA Associates or the local distributor from whom the instrument was purchased. It is helpful if a brief description of the fault symptoms can be provided.

## **7 Accessories**

### **7.1 Engraved Scale Plate**

A removable blank stainless steel plate is fitted above the display on every instrument. This plate can be supplied engraved with the units of measurement e.g. °C, Bar, kg/hr

### **7.2 Engraved Tagging Plate**

A removable blank stainless steel plate is fitted below the display on every instrument. This plate can be supplied engraved with tagging information such as the instrument function or loop identification.

### **7.3 Pipe Mounting Kit**

The standard pipe mounting kit enables the BA300N series indicator to be clamped onto any vertical or horizontal pipe-stand or pipe having a diameter between 60 and 80mm. Each kit is supplied with an instruction sheet.

Special kits for larger or smaller pipes are available.

## **8 Customer Comments**

BEKA Associates is always pleased to receive comments from customers about products and services. All communications are acknowledged and whenever possible, suggestions are acted upon.





## APPENDIX 2: Product Specification

## DIMENSIONS (MM)

<b>Input</b>	
current	4 to 20mA
voltage drop at 20mA	Less than 1V @ 20°C Less than 1.1V @ -20°C ±200mA will not cause damage
<b>Display</b>	
type	3½ digits (-1999 to 1999) liquid crystal 25mm high.
span	Adjustable between: 000 & 1999 for 4 to 20mA input
zero	Adjustable between: -1000 & 1000 with 4mA input in linear mode only
polarity	Automatic minus sign.
decimal point	1 of 3 positions, or absent, selected by link
reading rate	2.5 per second.
overrange	3 least significant digits are blanked.
<b>Operating modes</b>	linear or root-extracting selected by plug-in link
<b>Accuracy</b>	
linear mode	±0.1% of display ± 1 digit
root-extractor mode	±16µA @ input ± 1 digit for input currents between 4.16 and 20mA (10 to 100% of flow) within ± 15 digits of zero
display @ 4mA	
Temperature effect on:	
span	typ 50ppm, max 100ppm/°C
zero	typ 0.05 digit + 100ppm/°C max 0.1 digit + 200ppm/°C
root extractor	±0.1µA/°C @ input
series mode rejection	Typ 1 digit error for 1Vpk to pk 50Hz signal.
<b>Intrinsic Safety</b>	
BASEEFA	
standard	BS4683: Part 3: 1972
code	Ex N II T6
certificate number	BAS Ex 87Y4139
location	Zone 2
installation	The BA314N may be used in Zone 2 hazardous areas when installed to BS5345: Part 7: 1979. Also see certificate.
<b>Environmental</b>	
operating temperature	-20 to +60°C
humidity	to 95% @ 40°C
case	Hose-proof (IP65)
<b>Mechanical</b>	
terminals	Screw clamp for 0.5 to 2.5mm cables.
weight	1.2kg
<b>Accessories</b>	
engraved scale plate	removable blank stainless steel plate fitted to each indicator, can be supplied engraved with units of measurement.
engraved tag plate	removable blank stainless steel plate fitted to each indicator, can be supplied engraved with tagging information.
pipe mounting kit	mounts indicator onto any vertical or horizontal pipe with diameter between 60 & 80mm. For larger or smaller pipes special kits are available.

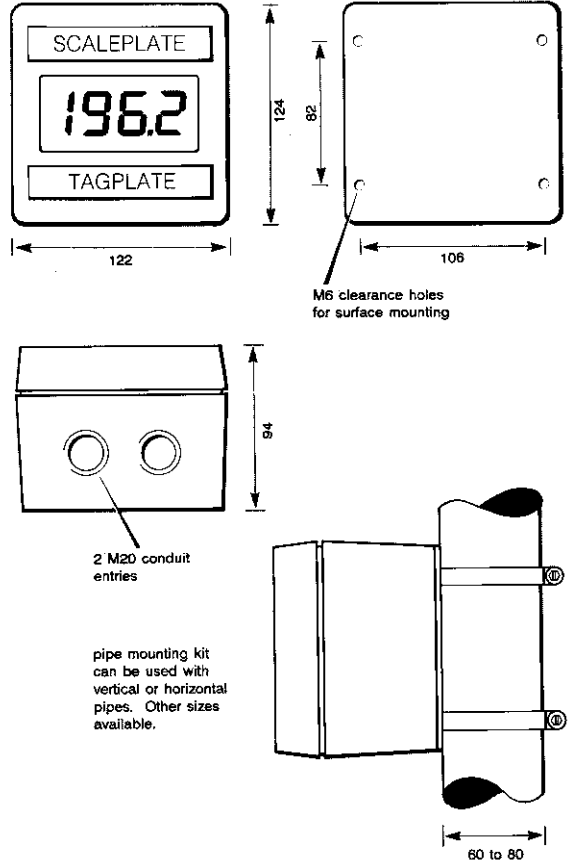

**BEKA Associates Ltd.** PO Box 39, Hitchin, Herts. SG5 2DD, UK    Tel: (0462) 438301    Fax: Hitchin (0462) 453971    Printed in England