

# BA544D

## Battery powered pulse input field mounting rate totaliser

Issue 4

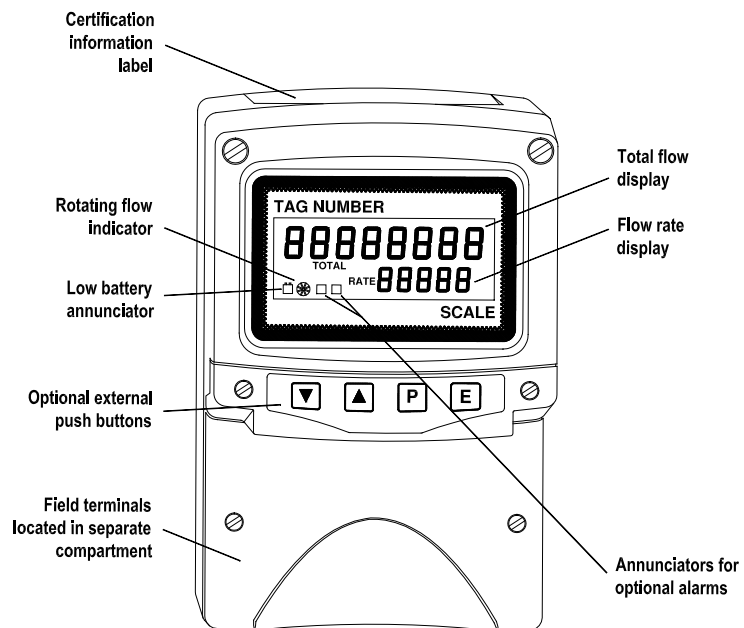

## CONTENTS

- 1. Description**
- 2. Operation**
  - 2.1 Controls
  - 2.2 Displays
- 3. System Design**
  - 3.1 Flow transmitter loops
  - 3.2 Pulse input
  - 3.3 Remote reset
- 4. Installation**
  - 4.1 Location
  - 4.2 Installation procedure
  - 4.3 EMC
  - 4.4 Installing a replacement battery
  - 4.5 Disposal of used batteries
- 5. Programming and Calibration**
  - 5.1 Calibration structure
  - 5.2 Accessing programme functions
  - 5.3 Summary of programmable functions.
  - 5.4 Display update interval
  - 5.5 Type of input
  - 5.6 Position of the decimal points
  - 5.7 Lower display
  - 5.8 Rate scale factor
  - 5.9 Timebase
  - 5.10 Rate filter
  - 5.11 Total scale factor
  - 5.12 Clip-off
  - 5.13 Local reset
  - 5.14 Resetting grand total
  - 5.15 Security code
- 6. Calibration Example**
  - 6.1 Calibration procedure
- 7. Maintenance**
  - 7.1 Fault finding during commissioning
  - 7.2 Fault finding after commissioning
  - 7.3 Servicing
  - 7.4 Routine maintenance
  - 7.5 Guarantee
- 8. Accessories**
  - 8.1 Units of measurement and instrument identification.
  - 8.2 Alarms
    - 8.2.1 Solid state output
    - 8.2.2 Programming and adjustment
    - 8.2.3 Alarm enable
    - 8.2.4 Type of alarm
    - 8.2.5 Setpoint adjustment
    - 8.2.6 Alarm function
    - 8.2.7 Alarm output status
    - 8.2.8 Hysteresis
    - 8.2.9 Alarm delay
    - 8.2.10 Alarm silence time
    - 8.2.11 Access setpoint
    - 8.2.12 Adjusting alarm setpoints from display mode.
  - 8.3 External push-buttons
  - 8.4 Pipe mounting kits
  - 8.4 Stem mounting kit
- 9. Index**
- Appendix 1**  
BA491 replacement battery

<p>The BA544D is CE marked to show compliance with the the European EMC Directive 2004/1-8/EC</p>
---

## 1. DESCRIPTION

The BA544D is a battery powered pulse input rate totaliser primarily intended for use with flowmeters. The instrument simultaneously displays the rate of flow and the total flow in engineering units on two separate displays.

Housed in a robust IP66 glass reinforced polyester (GRP) enclosure with an armoured glass window, the BA544D is surface mounting, or may be pipe mounted using one of the accessory kits. A stem mounting kit is also available allowing direct mounting onto a flowmeter conduit entry.

## 2. OPERATION

Fig 1 shows a simplified block diagram of a BA544D. The instrument accepts a pulse input which, after scaling is displayed as the total number of pulses received and their rate on two separate displays. When connected to a pulse output flowmeter the BA544D will provide an accurate display of total flow and the rate of flow. The BA544D has two sets of input terminals allowing connection to high or low level voltage pulses, switch contacts or to an open collector output, it may therefore be used with most flowmeters. The total display may be reset to zero by a remote switch contact, the internal switches or via the optional external keypad.

Optional alarms, which may be programmed to function on the rate or total displays, further extend the applications of this instrument.

The BA544D contains an internal replaceable battery that will power the instrument for up to five years. Battery life depends upon how the BA544D is programmed and the pulse input frequency. Replacement BA491 batteries may be installed with the BA544D in situ.

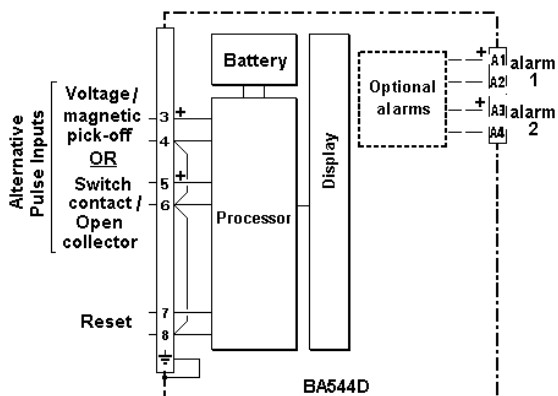

Fig 1 Simplified block diagram of BA544D

## 2.1 Controls

The BA544D is controlled and calibrated via four push-button switches which are located behind the instrument control cover, or as an option on the outside of the control cover. In the operating mode, i.e. when the instrument is displaying rate and total flow, the switch functions are:

### Description of Switch Functions

**E+ Down** While these buttons are pushed the total display will show the least significant eight digits of the grand total, and the grand total annunciator will be activated.

**E+Up** While these two buttons are pushed the total display will show the most significant eight digits of the grand total and the grand total annunciator will be activated.

**Down +Up** The total display is reset to zero when these two push-buttons are operated simultaneously for two seconds. This function may be turned on or off from within the programme menu. See section 5.13

**P +Down** While these buttons are pushed the instrument will display the firmware part number and version number.

**Note:** When optional alarms are fitted the push-buttons may be programmed to have alternative functions – see section 8.2

## 2.2 Displays

The BA544D has two digital displays and associated annunciators, plus a flow indicator as shown on page 1.

<b>Rate Display</b>	Shows the flow rate on the smaller six digit display.
<b>Total display</b>	Shows the total flow on the larger eight digit display. Set to zero when local or remote reset switch is operated.
<b>Flow indicator</b>	This disc in the lower left hand corner of the display 'rotates' while input pulses are being received. It will stop rotating within two seconds of the end of a display update period in which no pulses were received.
<b>Hold annunciator</b>	Activated when input frequency is below the clip-off threshold.
<b>Low battery Annunciator</b>	Battery symbol containing word 'LO' is activated when internal battery requires replacement.

## 2.3 Internal battery

The BA544D rate totaliser is powered by a BA491 replaceable lithium battery that is mounted within the instrument. This will operate the BA544D for about five years, the exact time depends upon how the instrument is programmed and used, whether alarms are fitted and the input pulse frequency. A low battery alarm annunciator on the instrument display will be activated when the battery requires replacing. Normally the rate totaliser will continue to operate for about five hundred hours after the annunciator is activated, but the exact time will depend upon how the instrument is programmed, whether alarms are fitted and the input frequency. During this period the total and grand total will continue to be transferred to permanent memory once per hour. When the battery is exhausted the total and grand total will be stored in permanent memory, totalisation will stop and the instrument will display 'bAtt'.

## 3. SYSTEM DESIGN

### 3.1 Flow transmitter loops

The BA544D may be connected to almost any pulse output flowmeter and calibrated to display rate and total flow in the same or different engineering units.

Fig 2 illustrates the basic circuit that is used for all BA544D installations.

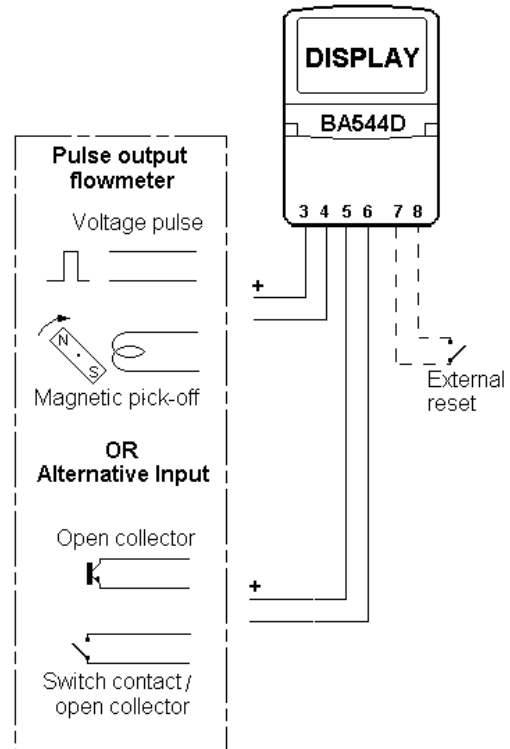

Fig 2 BA544D flow application

### 3.2 Pulse input

As shown in Fig 2, the BA544D will count pulses from a wide variety of transducers enabling it to display the output from almost any flowmeter.

The instrument has one pulse input, but two sets of input terminals enabling it to accommodate different types of transducers. Terminals 3 and 4 are for voltage pulse inputs and terminals 5 and 6 are for contact and open collectors inputs.

**Note:** Only one pair of input terminals may be used at a time. i.e pulses can not be counted from terminals 3 & 4 and from terminals 5 & 6 at the same time.

The following table shows the switching thresholds for the various transducers, plus the

maximum operating frequency and the input terminal numbers. For reliable counting the input signal must fall below the lower threshold and rise above the upper threshold.

	Switching thresholds		Freq max	Input terminals
<b>Switch</b>	100Ω	1000Ω	100Hz	5 & 6
<b>Open collector</b>	2kΩ	10kΩ	10kHz	5 & 6
<b>Magnetic pick-off</b>	0mV	40mV	10kHz	3 & 4
<b>Voltage pulse</b>	1.0V	3.0V	10kHz	3 & 4

### 3.3 Remote reset

The BA544D total display is reset to zero when terminals 7 & 8 are connected together for more than one second. Permanent interconnection of these terminals will stop totalisation and may be used as an inhibit function. There is no practical limit on the distance that the reset switch may be from the totaliser.

Alternatively, the BA544D may be programmed so that the total display is reset to zero when the *Up* and *Down* push-buttons are operated simultaneously for more than two seconds. – see 5.13

**Note:** Each time the total display is reset to zero, the grand total is stored in permanent memory.

## 4. INSTALLATION

### 4.1 Location

The BA544D rate totaliser is housed in a robust IP66 glass reinforced polyester (GRP) enclosure incorporating an armoured glass window and stainless steel fittings. It is suitable for exterior mounting in most industrial environments, including off-shore and waste water treatment installations. Please consult BEKA associates if high vibration is anticipated.

The BA544D enclosure is surface mounting. Accessory kits described in sections 8.4 & 8.5 of this manual enable the instrument to be mounted onto a vertical or horizontal pipe, or directly onto a flowmeter conduit entry.

The field terminals and the two mounting holes are located in a separate compartment with a sealed cover allowing the instrument to be installed without exposing the display assembly.

The BA544D earth terminal is connected to the internal EMC filters. For maximum radio frequency interference rejection this terminal should be connected to a local earth, or to an earthed cable screen.

The BA544D enclosure is supplied with a bonding plate to ensure electrical continuity between the three conduit / cable entries.

### 4.2 Installation Procedure

Fig 3 illustrates the instrument installation procedure.

- a. Remove the instrument terminal cover by unscrewing the two captive 'A' screws.
- b. Mount the instrument on a flat surface and secure with two M6 screws through the 'B' holes. Alternatively use one of the mounting kits described in section 8.4 & 8.5
- c. Remove the temporary hole plug and install an appropriate IP rated cable gland or conduit fitting. If more than one entry is required, one or both of the IP66 stopping plugs may be replaced with an appropriate IP rated cable gland or conduit fitting.
- d. Connect the field wiring to the terminals as shown in Fig 4.

- e. If the instrument is about to be commissioned, turn the BA544D ON by moving the slide switch located above terminals 3 and 4 to the right. See Figs 3 & 4.

**Note:** If the instrument has not been switched on recently it may take a few minutes to start functioning. If the instrument does not start, please refer to the battery configuration instructions in Appendix 2.

- f. Replace the instrument terminal cover and evenly tighten the two 'A' screws.

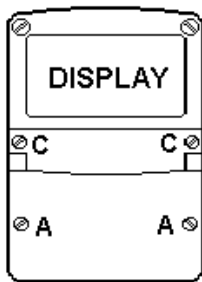
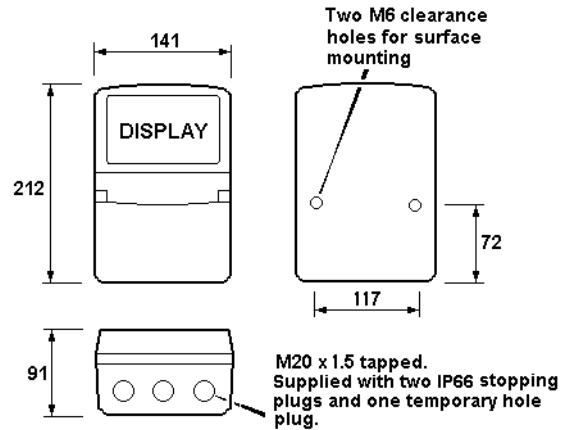

Remove the terminal cover by unscrewing the two 'A' screws

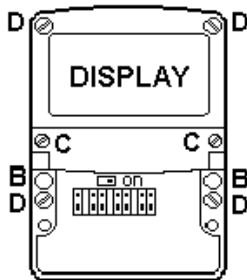

Secure the instrument to a flat surface with M6 screws through the two 'B' holes. Alternatively use a pipe mounting kit.

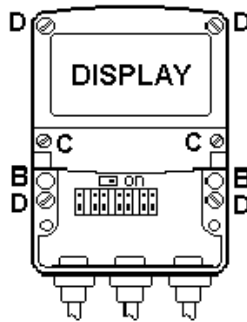

Install cable glands, conduit fittings or blanking plugs and terminate field wiring. If the instrument is about to be commissioned put the ON / OFF switch in the ON position. Finally replace the terminal cover and tighten the two 'A' screws.

Fig 3 BA544D installation procedure

**4.3 EMC**

The BA544D complies with the requirements of the European EMC Directive 2004/108/EC. For specified immunity all wiring should be in screened twisted pairs. The BA544D earth terminal should be locally earthed or connected to an earthed cable screen.

To prevent circulating currents, cable screens should only be earthed at one point.

**4.4 Installing a replacement battery**

The internal battery will power the BA544D rate totaliser for about five years; the exact time depends upon how the instrument is programmed and the input pulse frequency. When the battery requires replacing the low battery alarm annunciator on the instrument display will be activated indicating that the rate totaliser will continue to operate for about another five hundred hours. When the battery is exhausted the total and grand total will be stored in permanent memory, totalisation will stop and the instrument will display 'bAtt'.

Replacement batteries are available from BEKA associates and our agents. When not installed in an instrument, at 20°C the battery only loses about one percent of its charge each year, so it is practical to hold spares on-site. This long shelf life results from an oxide layer which forms on the battery internal electrodes and may need clearing before use – see 4.3e and Appendix 1.

Fig 4 Dimensions and terminal connections

**WARNING**

**Only BA491 batteries should be fitted. No attempt should be made to recharge or to open the battery assembly.**

The discharged battery may be removed and the replacement fitted while the BA544D rate totalisers is in situ. Fig 5 together with the following notes illustrate the replacement sequence:

- a. If the instrument has an external keypad, remove the switch cover by unscrewing the two 'C' screws and unplug the ribbon cable from the outer row of pins.

- b. **CAUTION**  
**The total and grand total are automatically stored in permanent memory once every hour. If the instrument is still operational i.e. has a display other than 'bAtt', turning the instrument off may result in up to 59 minutes of flow being lost from these displays. Entering and leaving the programme menu by pressing P and E followed by E, will force the BA544D to immediately store the totals in permanent memory thus preventing data loss.**

Remove the terminal cover by unscrewing the two 'A' screws and turn the instrument OFF by moving the slide switch to the left – see Figs 3 & 4.

- c. Remove the four 'D' screws and lift-off the front of the enclosure.
- d. Remove the two 'E' screws securing the BA491 battery and gently pull the battery away from the instrument printed circuit board – see Fig 5.
- e. Before installing a replacement BA491 battery it should be conditioned to remove the oxide layer that forms on the internal electrodes, please see instruction sheet supplied with each replacement BA491. Battery conditioning is also described in Appendix 1.

- f. Plug the replacement BEKA BA491 battery into the instrument. Ensure that the two pins on the instrument printed circuit board are correctly aligned with the socket on the battery and then replace the two 'E' screws.
- g. Reassemble the instrument enclosure. Before replacing the terminal cover turn the instrument ON by moving the slide switch to the right.

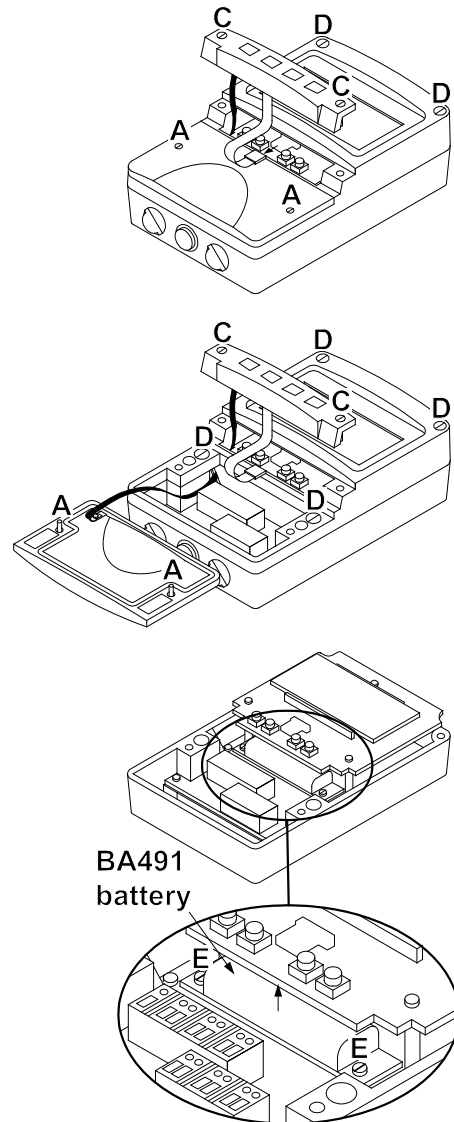

Fig 5 Replacement of internal battery

#### 4.5 Disposal of used batteries

The BEKA BA491 battery contains Lithium Thionyl Chloride cells that should not be included with standard industrial waste. Do not incinerate.

More information about disposal is available from The British Battery Manufacturers Association [www.rebat.com](http://www.rebat.com)

## 5. PROGRAMMING & CALIBRATION

The BA544D is programmed and calibrated via four push-buttons which are located behind the instrument control cover, see Fig 8. If frequent access to the push-buttons is required, the rate totaliser can be supplied with duplicate membrane push-buttons mounted on the outside of the control cover.

All the programming functions are contained in an easy to use menu that is shown diagrammatically in Fig 7. Each function is summarised in section 5.3 and includes references to more detailed information. Although this simple menu driven system enables most adjustments to be made without repeated reference to this manual, it is recommended that at least the summary of the programmable functions in section 5.3 is read before attempting programming or recalibration.

When the BA544D is fitted with optional alarms the basic menu is expanded to include the option. Section 8.2 of this manual explains how to programme these additional functions.

**Note:** While the instrument is being programmed or calibrated, totalisation continues so that any flow occurring during this time is recorded.

### 5.1 Calibration structure

Fig 6 shows the BA544D calibration structure. The rate and total display calibration functions are totally independent allowing the displays to have different units of measurement.

For the rate display the pulse input is scaled by SCALE-r to show the required units of measurement and multiplied by the timebase t-bASE to calculate and display the rate of flow per second, minute or hour.

Similarly, to calculate the total flow in the required units of measurement, the number of input pulses is divided by the total scale factor SCALE-t. Total flow is continuously added to the grand total.

The BA544D uses floating point arithmetic and 'real' decimal points. Moving the position of a decimal point will therefore affect the instrument calibration and display.

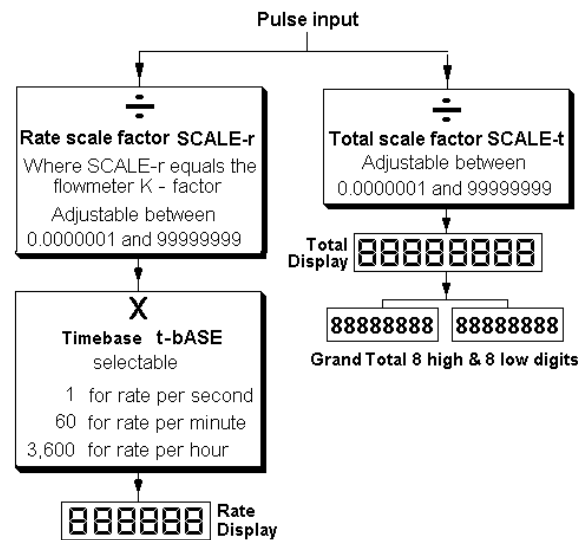

Fig 6 Calibration structure

### 5.2 Accessing programming functions

Throughout this manual push-buttons are shown in italics e.g. *P* or *Up* push-button, and legends displayed by the instrument are shown within inverted commas e.g. 'CAL' and 'ALr2'.

Access to the programme menu is obtained by operating the *P* and *E* push-buttons simultaneously. If the instrument is not protected by a security code the first parameter 'UPdAtE' will be displayed. If a security code other than the default code 0000 has already been entered, the instrument will display 'COdE'. Press *P* to clear this prompt and enter the security code for the instrument using the *Up* or *Down* push-buttons to adjust each digit, and the *P* push-button to move control to the next digit. If the correct code has been entered pressing *E* will cause the first parameter 'UPdAtE' to be displayed. If an incorrect code is entered, or a push-button is not operated within ten seconds, the instrument will automatically return to the display mode.

Apart from defining the position of the decimal point in the rate display all programme functions and prompts are shown on the large eight digit display.

Once within the main programme menu the required parameter can be reached by scrolling through the menu using the *Up* and *Down* push-buttons as shown by the programme structure in Fig 7.



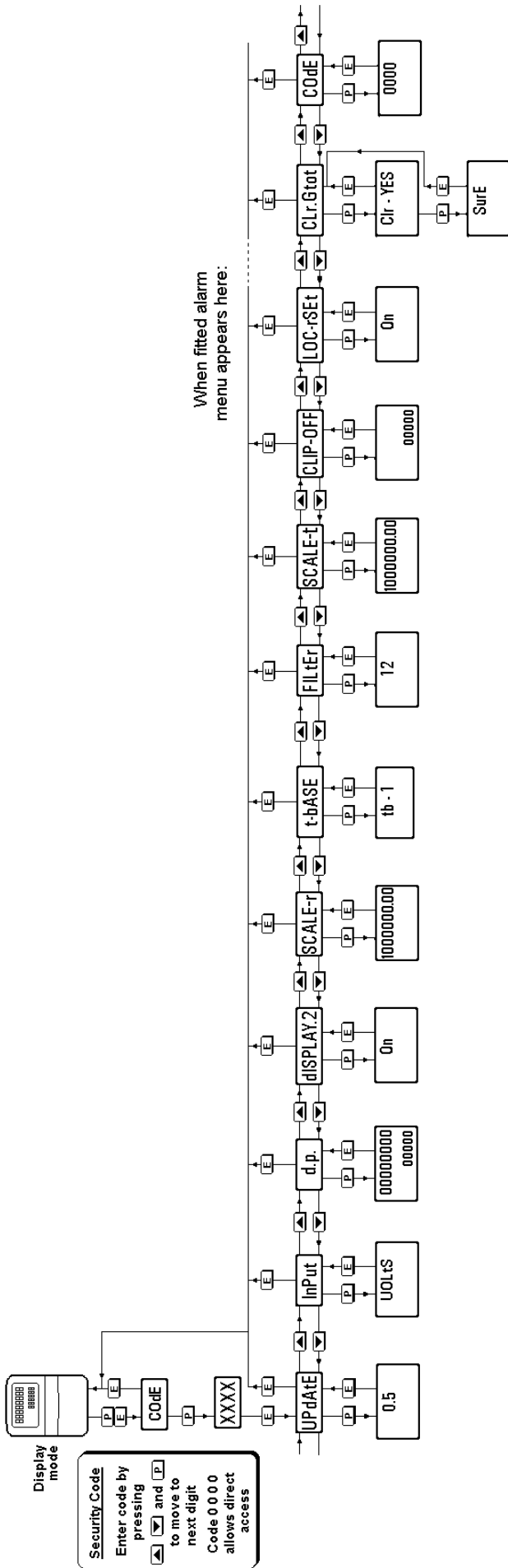

- Display update**  
time  
 $\Delta$  or  $\nabla$   
to select time between display updates  
0.5  
1.0  
2.0  
5.0  
10.0  
20.0  
seconds
- Input**  
 $\Delta$  or  $\nabla$   
to select type of input  
U0lts for voltage pulse  
COIL for magnetic pick-off  
COntAct for switch contact  
OP . COL for open collector
- Decimal point**  
 $\Delta$  or  $\nabla$   
to select position of decimal point and  $\nabla$  to toggle between displays  
Press  $\Delta$  +  $\nabla$  to interchange rate and total displays
- Lower display**  
 $\Delta$  or  $\nabla$   
to turn the lower display On or OFF
- Rate scale factor (K factor)**  
 $\Delta$  or  $\nabla$   
to adjust value and  $\nabla$  to move to next digit.  
Press  $\Delta$  +  $\nabla$  to position decimal point
- Timebase**  
 $\Delta$  or  $\nabla$   
to select totaliser timebase  
tb-1 for flow/sec  
tb-60 for flow/min  
tb-3600 for flow/hour
- Rate filter**  
 $\Delta$  or  $\nabla$   
to adjust value of each digit and  $\nabla$  to move to other digit.  
First digit filter magnitude  
Second digit step response
- Total scale factor**  
 $\Delta$  or  $\nabla$   
to adjust value and  $\nabla$  to move to next digit.  
Press  $\Delta$  +  $\nabla$  to position decimal point
- Clip-off**  
 $\Delta$  or  $\nabla$   
to adjust rate display at which clip-off occurs
- Local reset**  
 $\Delta$  or  $\nabla$   
to turn the local reset function On or OFF  
When On is selected total display is reset to zero when  $\Delta$  and  $\nabla$  are operated simultaneously
- Clear grand total**  
 $\Delta$  or  $\nabla$   
to select CLr.YES confirmed by entering Sure using  $\Delta$  or  $\nabla$  to adjust display and  $\nabla$  to move to next digit  
**WARNING**  
Cleared grand total can not be recovered
- Define Security Code**  
Enter by pressing  $\Delta$  or  $\nabla$  to move to next digit and  $\nabla$  to move to next digit

Fig 7 Programme Structure

All new BA544D rate totalisers are supplied calibrated as requested at the time of ordering. If calibration information is not supplied, the instrument will be conditioned for an open collector input, with SCALE-r and SCALE-t set to 1 and a timebase of seconds.

### 5.3 Summary of programmable functions

This section summarises all the programmable functions. When read in conjunction with Fig 7 it provides a quick aid for programming the instrument. If more detail is required, each section contains a reference to a full description of the function.

<b>SUMMARY</b>	
<b>Display</b>	<b>Description of function</b>
<b>'UpdAtE'</b>	<p><b>Display update time</b> Allows the interval between display updates to be selected. Updating the display less frequently lengthens battery life. See section 5.4</p>
<b>'InPut'</b>	<p><b>Type of input</b> Enables one of four types of input to be selected: 'UOLtS' Voltage pulse 'COIL' Magnetic pick-off 'ContACt' Switch contact 'OP.COL' Open collector See section 5.5</p>
<b>'d.P.'</b>	<p><b>Decimal points</b> Defines the position of the decimal point in both the rate and total displays and enables the rate and total displays to be interchanged. See section 5.6</p>
<b>'dISPLAY.2'</b>	<p><b>Lower display</b> Turns the lower display, which normally shows rate, on or off. See section 5.7</p>
<b>'SCALE-r'</b>	<p><b>Rate Scale Factor</b> Defines the arithmetic relationship between the pulse input frequency and the rate display. May be adjusted between 0.001 and 99999999. When used with a flowmeter, SCALE-r should be set to the flowmeter K factor (pulses per unit of measurement) if the display is required in the same units as the K factor. See section 5.8</p>
<b>'t-bASE'</b>	<p><b>Timebase</b> Selectable multiplier to display flow rate in units per second, per minute or per hour.. Select: tb-1 for flow / second tb-60 for flow / minute tb-3600 for flow / hour See section 5.9</p>
<b>'FILtEr'</b>	<p><b>Rate filter</b> Adjustable digital filter to reduce noise on the rate display. Two parameters each adjustable between 0 and 9. See section 5.10</p>
<b>'SCALE-t'</b>	<p><b>Total Scale Factor</b> Defines the arithmetic relationship between the number of input pulses and the total display.  May be adjusted between 0.001 and 99999999. When used with a flowmeter SCALE-t should be set to the flowmeter K factor (pulses per unit of measurement). See section 5.11</p>
<b>'CLIP-OFF'</b>	<p><b>Clip off</b> To prevent the totalisation of very low flow rates, clip-off enables the user to select a flow rate below which totalisation is inhibited. See section 5.12</p>

<b><u>Display</u></b>	<b><u>Description of function</u></b>
-----------------------	---------------------------------------

**'LOC.rSEt' Local reset of total display**

When turned 'On' the total display may be reset to zero from the display mode by simultaneously operating the *Up* and *Down* push-buttons for two seconds.

See section 5.13

**'CLr. Gtot' Clear grand total**

This function resets the grand total to zero when 'CLr YES' is selected. 'SurE' must be entered to confirm the instruction.

**Note:** Once cleared, a grand total can not be recovered.

See section 5.14

**'COdE' Security code**

Defines a four digit numeric code which must be entered to gain access to the programmable functions. Default code 0000 disables the security function and allows unrestricted access to all programmable functions.

See section 5.15

**5.4 Display update interval: 'UpdAtE'**

Six different intervals between display updates varying between 0.5 and 20 seconds may be selected. Increasing the interval between display updates will significantly lengthen battery life and make it easier to read a rapidly changing rate or total display. The selected update interval does not affect the accuracy of the display, but it will affect the response time of the optional alarms.

When any of the push-buttons are operated, the update time automatically changes to 0.5 seconds for 30 seconds to provide the fastest response while adjustments are being made.

To define the update interval select 'UpdAtE' from the main menu and press *P* to reveal the current time. Pressing the *Up* or *Down* button will scroll through the six times. When the required interval has been selected press *E* to return to the main menu.

**5.5 Type of input: 'InPut'**

The BA544D may be programmed to accept pulse inputs from a wide variety of sensors. To define an input type select 'InPut' from the menu and press *P* which will reveal the current

input type. Pressing *Up* or *Down* will scroll through the four options:

'UOLts'	Voltage pulse input Threshold 1V and 3V 10kHz max. Input terminals 3 and 4
'COIL'	Low voltage pulse Threshold typically 40mV peak to peak ac.10kHz max. Input terminals 3 and 4
'COntACT'	Switch contact Threshold 100 and 1000Ω 100Hz max. Input terminals 5 and 6
'OP.COL'	Open collector Threshold 2 and 10kΩ 10kHz max. Input terminals 5 and 6

When the required type of input has been selected press *E* to return to the main menu.

**Note:** To count reliably, the input signal must fall below the lower switching threshold and rise above the higher switching threshold.

**5.6 Position of the decimal points: 'd.P.'**

The rate display can have up to six digits and the decimal point may be positioned between any of them, or omitted. Similarly, the total display has eight digits and the decimal point may be positioned between any of them, or may be omitted.

To adjust the position of either decimal point select 'd.P.' from the main menu and press *P*. This will activate both displays with one digit plus the following decimal point of the total display flashing. If only the least significant digit is flashing, this indicates that the decimal point is omitted.

The position of the decimal point can be moved by pressing the *Up* or *Down* push-button. Operating the *P* push-button will toggle control between the two displays. When both decimal points have been correctly positioned press *E* to return to the main menu.

If the application requires flow rate to be the primary display i.e. shown on the large display, the d.P. function enables the rate and total displays to be interchanged. The rate display will continue to have six digits but the total display will be reduced from eight to six digits. The rate and total annunciators will also be exchanged. Pressing the *Up* and *Down*

buttons simultaneously will exchange the displays.

**Note:** Both decimal points must be repositioned after the displays have been exchanged.

### 5.7 Lower display: 'DISPLAY.2'

This function turns the lower display on or off. When turned off, the BA544D will only have one eight digit display which may be programmed to show total flow or rate of flow.

To check the status of the lower display select 'DISPLAY.2' from the menu and press *P* which will reveal if the function is 'On' or 'OFF'. The settings may be changed by pressing the *Up* or *Down* button followed by the *E* button to return to the menu.

### 5.8 Rate scale factor: 'SCALE-r'

Together with the instrument timebase, this function defines the arithmetic relationship between the pulse input frequency and the rate display. When used with a flowmeter SCALE-r should be set to the K-factor of the flowmeter i.e. the number of pulses the flowmeter produces for a unit of flow. e.g. 45.6 pulses per litre. See section 6 for a worked example.

SCALE-r is a dividing factor that may be adjusted between 0.001 and 99999999.

To check or change the total scale factor select 'SCALE-r' from the main menu and press *P* to reveal the existing setting, one digit will be flashing. The value of the flashing digit can be changed by pressing the *Up* or *Down* buttons. When this digit is correct pressing *P* will transfer control to the next digit.

To position the decimal point in the rate scale factor, move the flashing digit to the left hand side of the required decimal point position and simultaneously press the *Up* and *Down* buttons.

When the required rate scale factor has been entered, press *E* to store the number and return to the main menu.

### 5.9 Timebase: 't-bASE'

The timebase multiplies the rate display by 1, 60 or 3,600 depending upon whether the BA544D is required to display rate per second, per minute or per hour. See Fig 6.

To check or change the timebase, select 't-bASE' from the main menu and press *P*

which will reveal the current setting. Pressing the *Up* or *Down* button will index through the three options:

tb-1	for flow / second
tb-60	for flow / minute
tb-3600	for flow / hour

Select the required multiplier and press *E* to return to the main menu.

### 5.10 Rate filter: 'FILtEr'

This digital filter has two independent adjustable parameters enabling the rate display frequency response to be tailored for optimum performance.

The filter parameters are controlled by a two digit number. The first digit defines the amount of filtering applied to the display as shown below.

First digit	Filter time constant seconds
0X	0
1X	1.3
2X	4.3
3X	6.5
4X	8.7
5X	11.3
6X	15.7
7X	20.9
8X	25.2
9X	31.5

The second digit defines the deviation from the displayed rate at which the filter will be overridden and the rate display will move rapidly to the new value.

Second digit	Magnitude of step change which will produce a rapid response
X0	Off
X1	1%
X2	2%
X3	4%
X4	8%
X5	12%
X6	16%
X7	24%
X8	32%
X9	64%

By careful adjustment of the two parameters a stable display with an acceptable step input response can be obtained for most applications.

During commissioning it is recommended that initially the second digit is set to 0 (off) and the first digit is adjusted to provide acceptable rate

display stability. The second digit should then be increased until the selected step size is greater than the noise on the display signal, at which setting the rate display will again become stable. These will be the optimum filter parameters for acceptable rate display stability and a fast response to a large rate signal change.

To check or change the filter select 'FILtEr' from the main menu and press *P* to reveal the current settings. Pressing the *Up* or *Down* button will change the flashing digit and *P* will transfer control to the second digit. While making adjustments the filtered rate display is shown on the lower display so that stability can be assessed. When set as required, press the *E* button to enter the revised parameters and return to the main menu.

#### 5.11 Total scale factor: 'SCALE-t'

This factor defines the arithmetic relationship between the number of input pulses and the total display. SCALE-t is a dividing factor that may be adjusted between 0.001 and 99999999. See Fig 6.

When used with a flowmeter SCALE-t should be set to the K-factor of the flowmeter i.e. the number of pulses the flowmeter produces for a unit of flow. If the BA544D total display is required in units different from those in which the flowmeter K factor is specified, a conversion factor will be required.

e.g. If the flowmeter has a K factor of 45.6 pulses per litre and the BA544D total display is required in units of 1,000 gallons, then SCALE-t should be set to number of pulses produced by the flowmeter per 1,000 gallons:

$$45.6 \times 4.54609 \times 1000$$

$$207,301.7 \text{ pulses per } 1000 \text{ gallons}$$

(there are 4.54609 litres in a UK gallon)

To check or change the total scale factor select 'SCALE-t' from the main menu and press *P* to reveal the existing setting, one digit will be flashing. The value of the flashing digit can be changed by pressing the *Up* or *Down* buttons. When this digit is correct pressing *P* will transfer control to the next digit.

**Note:** After changing the total scale factor, the total and grand total displays will be reset to zero.

To position the decimal point in the scale factor, move the flashing digit to the left hand side of the required decimal point position and simultaneously press the *Up* and *Down* buttons.

When the required total scale factor has been entered, press *E* to store the number and return to the main menu.

#### 5.12 Clip-off: 'CLIP-OFF'

To prevent totalisation of very low flow rates which over long periods may result in significant totalisation errors, the BA544D may be programmed to stop totalising when the flow rate falls below an adjustable threshold.

To check or change the clip-off threshold select 'CLIP-OFF' from the main menu and press *P* which will reveal the current setting. The threshold is shown in units of flow rate with one digit flashing. The value of the flashing digit may be changed by pressing the *Up* or *Down* buttons. When this digit is correct pressing *P* will transfer control to the next digit. When set as required, press the *E* button to enter the revised figure and return to the main programme menu.

If the flow rate falls below the entered threshold, the rate display will show zero flow, totalisation will stop and the HOLD annunciator will be activated. The flow indicator will continue to rotate as defined in section 2.2

**Note:** When the rate scale factor SCALE-r, the timebase t-bASE, or the position of the rate display decimal point are changed, clip-off will automatically be reset to zero. If required, a new clip-off threshold may then be entered.

#### 5.13 Local reset of total display: 'LOC. rSET'

When activated this function enables the operator to reset the BA544D total display to zero in the display mode by operating the *Up* and *Down* push-buttons simultaneously for two seconds. To check the status of the local reset function select 'LOC.rSET' from the menu and press *P* which will reveal if the function is 'On' or 'OFF'. If necessary press the *Up* or *Down* button to change the setting, followed by the *E* button to return to the main menu.

The total display may also be reset to zero remotely by connecting terminals 7 and 8 together. See section 3.4 of this manual.

#### 5.14 Resetting grand total: 'CLr. Gtot'

The grand total is a separate sixteen digit counter which duplicates the total display but is not zeroed when the total display is reset to zero. The grand total may be viewed in the display mode in two eight digit sections as described in section 2.1 of this manual.

The grand total counter can only be reset to zero from the 'CLr.Gtot' function in the main programme menu. To zero the grand total counter select 'CLr.Gtot' and press *P* which will cause the instrument to display 'Clr. no' with 'no' flashing. Continuously press the *Up* or *Down* push-buttons until 'CLr. YES' is displayed and then press *P* which will result in a '0000' prompt. Using the *Up*, and *Down* buttons and the *P* button to move to the next digit, confirm the request by entering the password 'SurE'. Note 'S' is entered as '5'. Pressing *E* will then reset the grand total counter to zero and return the instrument to the 'CLr.Gtot' prompt in the main menu.

#### CAUTION

**After resetting the grand total to zero the old grand total can not be recovered.**

#### 5.15 Security code: 'CodE'

The calibration and conditioning of the instrument may be protected by a four digit security code which must be entered before access to the programme menu is granted. New instruments are programmed with the default security code 0000 which allows unrestricted access to all programming functions without entering a security code.

To enter a new security code select 'COdE' from the menu and press *P* which will cause the instrument to display the current security code. Each digit of the code can be changed using the *Up* and *Down* push-buttons, and the *P* button to move to the next digit. When the required code has been entered press *E* to return to the main menu. The revised security code will be activated when the indicator is returned to the operating mode.

If the security code is lost, access to the programmable functions can be obtained by moving the internal security link to the override position. The original security code can then be viewed by selecting 'CodE' from the main menu and pressing *P*.

To gain access to the security code link, remove the instrument control cover by undoing the two 'C' screws – see Fig 5. If the instrument is fitted with external push-buttons

the connecting ribbon cable should be unplugged from the outer row of the five pin connector. The security code override link is located on the inner row of the five pin connector as shown in Fig 8.

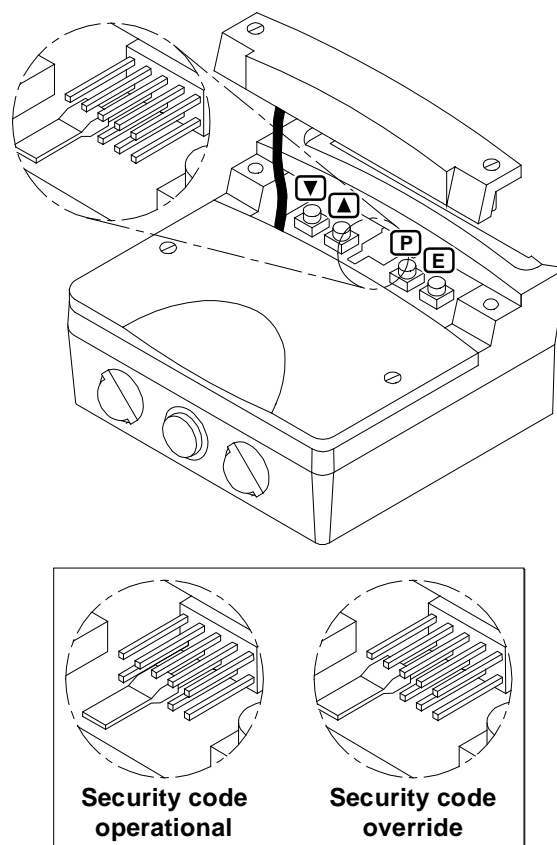

Fig 8 Location of security override link & function of push-buttons

## 6. CALIBRATION EXAMPLE

In this example a BA544D rate totaliser is connected to a turbine flowmeter having a K-factor of 105.0 pulses per litre. The flowmeter has a magnetic pick-off with a peak to peak output greater than 40mV at 1 litre per minute and a usable range of 1 to 40 litres per minute.

The BA544D is required to display rate of flow in litres per hour with a resolution of one litre and total flow in cubic metres with a resolution of 0.01 cubic metres. Totalisation is to stop when the flow rate falls below 1 litre per minute. To maximise battery life, the display is to be updated once every twenty seconds. Rate display filtering is required. In this application the operator needs to reset the total display to zero by simultaneously pushing the *Up* and *Down* push-buttons. To prevent tampering the instrument programme menu is to be protected by security code 1209

### 6.1 Calibration procedure

The BA544D rate totaliser may be calibrated on-site without disconnection from the power supply or from the flowmeter.

#### Step 1 Enter the programming mode

Put the BA544D in the programming mode by simultaneously pressing *P* and *E*. Assuming a security code has not already been entered the instrument will respond by displaying 'UPdAtE' which is the first function in the main menu. See Fig 7.

#### Step 2 Select the interval between display updates

With 'UPdAtE' displayed, press *P* to reveal the existing interval between display updates. If this is not as required, press the *Up* or *Down* button until '20' is displayed. (i.e. the display is updated once every twenty seconds). Enter the revised time and return to the 'UPdAtE' prompt in the main menu by pressing *E*.

#### Step 3 Select the type of input

Using the *Up* or *Down* button scroll through the main menu until 'InPut' is displayed, then press *P* to reveal the existing setting. Select 'COIL', the input for a magnetic pick-off, using the *Up* or *Down* button and

return to the 'InPut' prompt in the main menu by pressing *E*.

**Note:** The BA544D has two pairs of input terminals. 3 & 4 for voltage inputs and 5 & 6 for switch contact and open collector inputs. Ensure that the magnetic pick-off, which has a voltage output, is connected to terminals 3 & 4.

#### Step 4 Position rate & total decimal points

Select 'd.P.' from the main menu and press *P*. The rate and total displays will be activated with one digit of the total display flashing. Press the *Up* or *Down* push-button until the third least significant digit of the total display and following decimal point are flashing. This gives the required total display resolution of 0.01

Press *P* to move control to the rate display. Using the *Up* or *Down* push-button move the flashing digit to the least significant position (right hand side) which will result in no decimal point being displayed.

Finally press *E* to return to the 'd.P.' prompt in the main menu.

#### Step 5 Enter the rate scaling factor

Select 'SCALE-r' from the main menu and press *P* to show the current figure. The K factor of the flowmeter in this example is 105.0\* pulses per litre which should be entered as the rate scaling factor.

Firstly to position the decimal point, operate the *P* push-button to move the flashing digit to the second least significant position. Pressing the *Up* and *Down* buttons simultaneously will then position the decimal point in front of the least significant digit.

Using the *Up* and *Down* buttons to adjust each digit in turn and the *P* button to transfer control between digits, enter 105.0 Finally return to the 'SCALE-r' prompt in the main menu by pressing *E*.

\* Could also be entered as 105

**Step 6 Enter the rate timebase**

Select 't-bASE' from the main menu and press *P* to show the current setting. In this example the rate display is required in litres per hour. Using the *Up* or *Down* button scroll through the three options and select 'tb-3600' which will multiply the rate display by 3600. Return to the 't-bASE' prompt in the main menu by pressing *E*.

**Step 7 Adjust the rate filter**

The rate display filter parameters should be adjusted experimentally after installation to provide a stable rate display with an acceptable step response.

During commissioning it is recommended that initially the second digit of the rate parameters is set to 0 (step response off) while the first digit (amount of filtering) is adjusted to provide acceptable rate display stability. The second digit should then be increased until acceptable rate display stability is once again achieved.

To adjust the filter parameters select 'FILtEr' from the main menu and press *P* to reveal the current setting. The first digit will be flashing and may be adjusted using the *Up* or *Down* button. The *P* button will transfer control to the second digit. When both are set as required, return to the 'FILtEr' prompt in the main menu by pressing *E*.

**Note:** While adjusting the filter, the rate is shown on the lower display so that stability can be assessed.

**Step 8 Enter the total scaling factor**

The K factor of the flowmeter in this example is 105.0 pulses per litre and the total display is required in cubic metres.

There are 1000 litres in a cubic metre so the BA544D is required to display 1 cubic metre for every 105 x 1,000 pulses received. 'SCALE-t' should therefore be set to 105,000

Select 'SCALE-t' from the main menu and press *P* which will reveal

the current setting with one digit flashing. To position the decimal point, operate the *P* push-button to move the flashing digit to the least significant position. Pressing the *Up* and *Down* buttons simultaneously will then remove the decimal point.

Using the *Up* and *Down* buttons to adjust each digit in turn and the *P* button to transfer control between digits, enter 105000 - Finally return to the 'SCALE-t' prompt in the main menu by pressing *E*.

**Step 9 Define clip-off**

In this example totalisation is to be inhibited at flow rates below 1 litre per minute.

Select 'CLIP-OFF' from the main menu and press *P* which will reveal the clip-off threshold in litres per hour i.e. the same units already selected for the rate display. The most significant digit of the display will be flashing indicating that this digit may be adjusted. Pressing *P* five times will move the flashing digit to the third least significant position.

Using the *Up* and *Down* buttons set the second least significant digit to 6 i.e. a clip-off threshold of 60 litres per hour (1 litre per minute). Finally return to the 'CLIP-OFF' prompt in the main menu by pressing *E*.

**Step 10 Turn local reset on**

In this example the operator needs to reset the total display to zero by pressing the *Up* and *Down* buttons simultaneously. To activate the local reset function select 'LOC.rSEt' from the main menu and press *P* to display the current setting. Pressing the *Up* or *Down* button will toggle the display between 'On' and 'OFF'. Select 'On' and press *E* to return to the 'LOCrSEt' prompt in the main menu.



**Step 11 Reset the grand total to zero**

Before completing commissioning the grand total counter should be reset to zero. Select 'CLr. Gtot' from the main menu and press *P* which will cause the instrument to display 'Clr. no'. Toggle this to 'CLr. YES' using the *Up* or *Down* push-buttons and press *P* which will result in a '0000' prompt. Using the *Up*, and *Down* buttons and the *P* button to move to the next digit, confirm the request by entering the password 'SurE'. Note: S is entered as 5. Pressing *E* will then reset the grand total counter to zero and return the instrument to the 'CLr. Gtot' prompt in the main menu.

**Step 12 Define the security code**

Defining a security code prevents unauthorised access to the programme functions. Select 'COdE' from the main menu and press *P* which will reveal the existing security code. Using the *Up* and *Down* buttons enter the new code 1209 digit by digit. The *P* button will transfer control between digits. When the new code has been entered, press *E* to return to the main programme menu.

**Step 13 Return to the operating mode**

Following completion of programming and calibration, return the BA544D to the operating mode by pressing *E*. All the programming functions will now be stored in permanent memory and will be protected by the security code from accidental or unauthorised adjustment.

## 7. MAINTENANCE

### 7.1 Fault finding during commissioning

If a BA544D fails to function during commissioning the following procedure should be followed:

Symptom	Cause	Check:
No display	Instrument has not been switched ON.  Battery is not conditioned,	Position of slide switch above terminals 3 & 4. See Figs. 3 & 4.  See Appendix 1
Flow indicator not rotating	No input pulses, incorrect input terminals used, or incorrect type of input selected	That BA544D has been calibrated for the correct input.  That input signal is connected to correct input terminals and correctly polarised.
Flow indicator rotating but incorrect rate display	Incorrect calibration  Input below clip-off threshold	That rate scale factor and timebase are correctly programmed.  That clip-off threshold is set correctly.
Unstable rate display	Noisy pulse input signal	Source of noise and try to eliminate, or increase rate filter.
Correct rate display but incorrect total display	Incorrect calibration  Remote reset switch contacts closed	That total scale factor is correctly programmed.  That 'RESET' annunciator is not activated. If it is, check reset wiring and switch.
Unable to enter programme mode	Incorrect security code	That the correct security code is being used, or fit security link in override position. See Fig 8.

### 7.2 Fault finding after commissioning

#### ENSURE PLANT SAFETY BEFORE STARTING MAINTENANCE

If a BA544D fails after it has been functioning correctly, the following table may help.

Symptom	Cause	Check:
No display	Instrument has been switched OFF  If BA544D has been switched OFF for extended period battery may need conditioning.  Discharged battery	Position of slide switch above terminals 3 & 4. See Figs. 3 & 4.  See Appendix 1  If replacement battery restores operation
Low battery annunciator activated	Battery almost exhausted. Install replacement battery as soon as possible.	
Instrument displaying 'bAtt'	Battery exhausted. Install replacement.	
Flow indicator not rotating	No input pulses	Output from flowmeter and wiring between flowmeter and BA544D.
Flow indicator rotating, 'HOLD' annunciator activated	Input below clip-off threshold	Clip-off threshold and if necessary adjust.
Unstable rate display	Noisy pulse input signal	Source of noise and try to eliminate, or increase rate filter.

If this procedure does not reveal the cause of the fault, it is recommended that the instrument is replaced.

### 7.3 Servicing

We recommend that faulty BA544D rate totalisers are returned to BEKA associates or to our local agent in your area for repair.

### 7.4 Routine maintenance

The mechanical condition of the instrument and electrical calibration should be regularly checked. The interval between inspections depends upon environmental conditions. We recommend that initially instrument calibration should be checked annually.

### 7.5 Guarantee

Instruments which fail within the guarantee period should be returned to BEKA associates or our local agent. It is helpful if a brief description of the fault symptoms is provided.

## 8. ACCESSORIES

### 8.1 Units of measurement and instrument identification

All BA544D rate totalisers are fitted with a display label behind the armoured glass window. This label can be supplied printed with any units of measurement and tag information specified when the instrument is ordered. Alternatively the information may be added on-site via an embossed strip, dry transfer or a permanent marker.

To gain access to the display label remove the terminal cover by unscrewing the two 'A' screws which will reveal two concealed 'D' screws. – see Fig 5. Remove all four 'D' screws and carefully lift off the front of the instrument. Add the required legend to the display label, or replace with a new pre-printed label which is available from BEKA associates.

The BA544D can also be supplied with a blank or custom engraved stainless steel plate secured by two screws to the side of the instrument enclosure. This plate can accommodate:

1 row of 9 alphanumeric characters 10mm high

or 1 row of 11 alphanumeric characters 7mm high

or 2 rows of 18 alphanumeric characters 5mm high

### 8.2 Alarms

The BA544D can be supplied with two solid state single pole outputs that may be independently programmed as high or low, rate or total alarms with normally open or normally closed outputs.

#### WARNING

**These alarm outputs should not be used for critical safety applications such as a shut down system.**

When the battery is exhausted both BA544D alarm outputs will open irrespective of whether normally open or normally closed outputs have been selected. When designing a system an open output should therefore be the alarm condition.

Alarm annunciators on the instrument display indicate the status of both alarms. If an alarm delay or silence time has been selected the annunciator will flash during the delay or silence period.

Programmable functions for each alarm include adjustable setpoint, alarm delay time and alarm accept time. Hysteresis may be applied to rate alarms.

The 'UpdAtE' function in the main menu defines how frequently the total display is updated, this also defines the interval between alarm status updates. Six times varying between 0.5 to 20 seconds may be selected – see section 5.4. Increasing the interval between display updates will significantly increase battery life.

**Note:** Use of the alarm outputs may reduce battery life by about 5%

#### 8.2.1 Solid state output

Each alarm has a galvanically isolated single pole solid state switch output as shown in Fig 9. The outputs are polarised and current will only flow in one direction. Terminals A1 and A3 should be connected to the positive side of the supply.

$$\begin{aligned} V_{\max} &= 30\text{V dc} \\ I_{\max} &= 250\text{mA dc} \\ R_{\text{on}} &= 5\Omega + 0.6\text{V} \\ R_{\text{off}} &= \text{greater than } 180\text{k} \end{aligned}$$

**Note:** Because of the series protection diode some test meters may not detect a closed alarm output

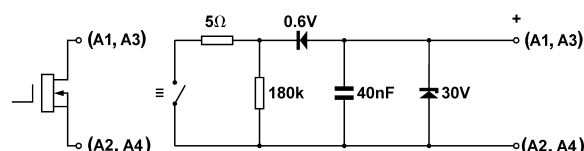

Fig 9 Equivalent circuit of each alarm output

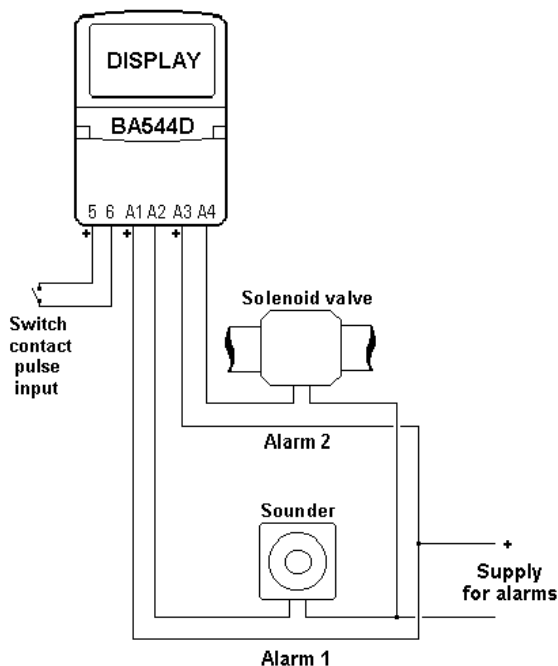

Fig 10 Typical alarm application

### 8.2.2 Programming and adjustment

When a BA544D is supplied with alarms the main programme menu is extended as shown in Fig 11. The two alarm functions appear between the 'LOC-rSEt' and the 'CLr.Gtot' functions, and each alarm may be programmed as a rate or a total alarm.

For simplicity Fig 11 only shows the programmable functions on the rate option of alarm AL1. Alarm 2 and the total options are identical except that the total alarms do not have hysteresis.

The following table summarises each of the alarm programme functions and includes a cross reference to more detailed information. Again only the functions on alarm AL1 are listed.

#### Summary of programmable alarm functions

<u>Display</u>	<u>Description of function</u>
'EnbL'	<b>Alarm enable</b> Enables or disables the alarm function without changing the alarm parameters. See section 8.2.3
'tYPE'	<b>Type of alarm</b> Defines whether the alarm operates on the rate or total display. See section 8.2.4
'SPr1' or 'SPt1'	<b>Alarm setpoint 1</b> Adjusts the alarm setpoint. The alarm is activated when the rate or total display equals the setpoint. <b>Note:</b> 'SPr1' is displayed for a rate alarm and 'SPt1' for a total alarm. See section 8.2.5
'HI.LO'	<b>Alarm function</b> Defines whether the alarm has a high or low function See section 8.2.6
'no.nc'	<b>Normally open or normally closed output</b> Determines whether the single pole alarm output is open or closed in the non-alarm condition. See section 8.2.7
'HStr'	<b>Hysteresis</b> Adjusts the alarm hysteresis. Only available on rate alarms. See section 8.2.8
'dELA'	<b>Alarm delay time</b> Adjusts the delay between the display equalling the setpoint and the alarm output being activated. See section 8.2.9
'SIL'	<b>Alarm silence time</b> Defines the time that the alarm output remains in the non-alarm condition following acceptance of an alarm. See section 8.2.10
'AcSP'	<b>Access setpoint</b> Sub-menu that enables direct access to the alarm setpoints from the display mode and defines a separate security code. See section 8.2.11

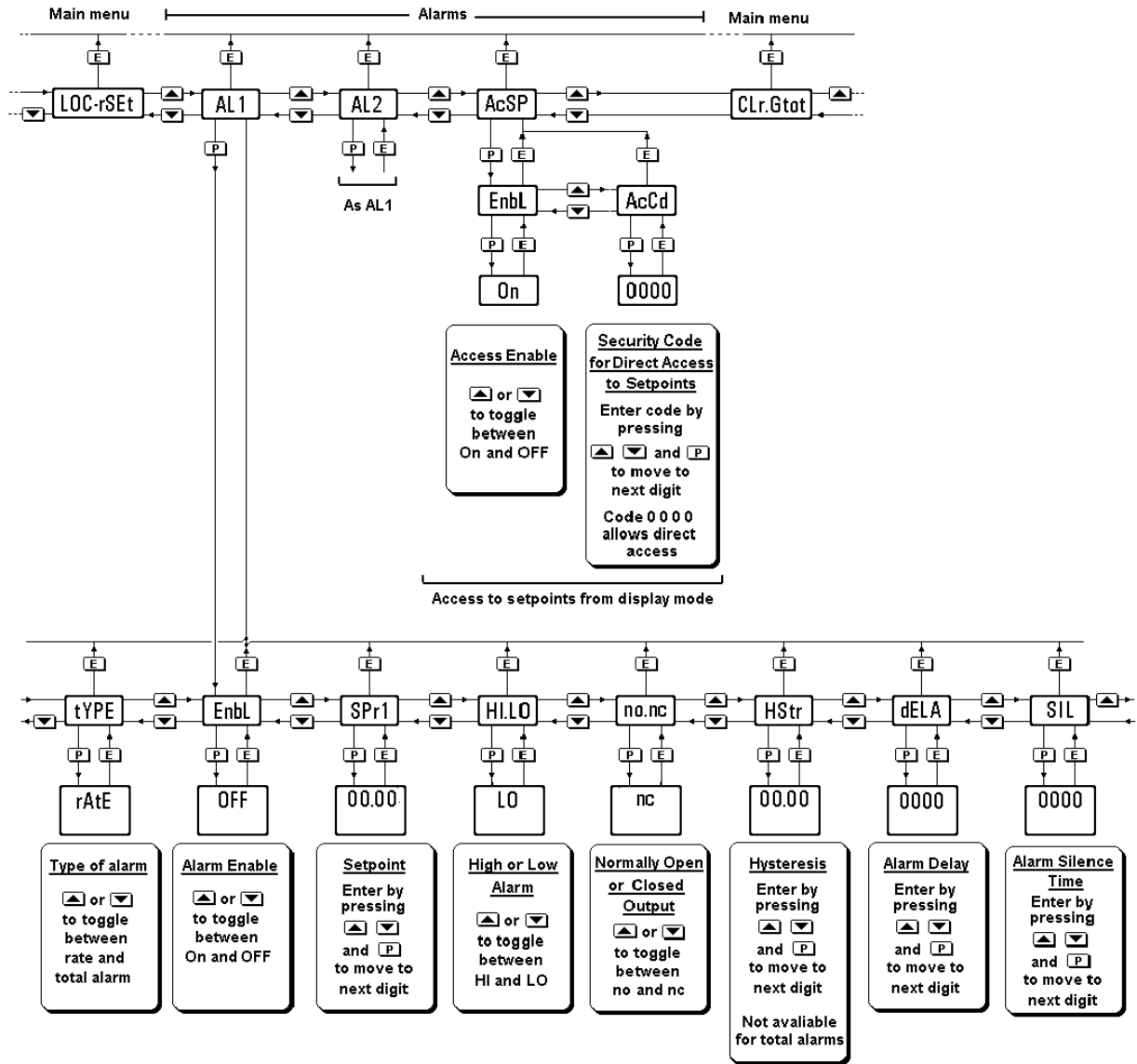

Fig 11 Alarm menu structure

**8.2.3 Alarm enable: 'EnbL'**

This function allows the alarm to be enabled or disabled without altering any of the alarm parameters. To check or change the function select 'EnbL' from the alarm menu and press *P* which will reveal the current setting. The function can be changed by pressing the *Up* or *Down* button followed by the *E* button to return to the alarm menu.

**8.2.4 Type of alarm: 'tYPE'**

Alarm 1 and Alarm 2 may both be rate or total alarms, or one may be conditioned for rate and the other for total.

To check or change the type of alarm, select 'tYPE' from the alarm menu and press *P* which will reveal the current setting. The function can be changed by pressing the *Up* or *Down* button followed by the *E* button to return to the alarm menu.

**Note:** To prevent accidental conditioning the alarm must be re-enabled after the alarm type has been changed – see 8.2.3.

### 8.2.5 Setpoint adjustment: 'SPx1' and 'SPx2'

The rate alarm setpoints SPr1 and SPr2 may be positioned anywhere between 0 and 999999, and the total alarm setpoint SPt1 and SPt2 anywhere between 00000000 and 99999999.

To adjust the setpoint of alarm 1 select 'SPr1' or 'SPt1', depending upon how it has been programmed, from the alarm menu. Press *P* which will reveal the existing value with one digit flashing. Each digit of the setpoint can be adjusted using the *Up* and *Down* push-buttons, and the *P* button to move to the next digit. The position of the decimal point is defined by the d.P. function which should be set first. When the required value has been entered press *E* to return to the alarm menu.

**Note:** 'SPr1' is displayed when alarm 1 has been programmed as a rate alarm and 'SPt1' when programmed as a total alarm.

### 8.2.6 Alarm function: 'HI.LO'

Each alarm must be conditioned as a high or low alarm. To check or change the alarm function select 'HI.LO' from the alarm menu and press *P* to reveal the current setting. The function can be changed by pressing the *Up* or *Down* buttons followed by the *E* button to return to the alarm menu.

### 8.2.7 Alarm output status: 'no.nc'

The two alarm outputs may be open or closed in the non-alarm condition. When the BA544D power supply is turned off or disconnected, both the alarm outputs will open irrespective of whether normally open or normally closed outputs have been selected. Therefore, when designing an alarm system, normally closed 'nc' should be selected so that the output opens when an alarm occurs or if the power supply fails.

To check the alarm output status select 'no.nc' from the alarm menu and press *P* to reveal the current setting. The function can be changed by pressing the *Up* or *Down* button followed by the *E* button to return to the alarm menu.

### 8.2.8 Hysteresis: 'HStr'

Hysteresis is only available on rate alarms. During programming hysteresis is shown in the units of rate the BA544D has been calibrated to display.

To adjust the hysteresis, select 'HStr' from the alarm menu and press *P* which will reveal the

existing figure. Each digit can be adjusted using the *Up* and *Down* push-buttons, and the *P* button to move to the next digit. When the required hysteresis has been entered, press *E* to return to the alarm menu.

e.g. A BA544D calibrated to display a flow of 0 to 5000, with a high alarm set at 4000 and hysteresis of 100 will perform as follows:

High alarm will be activated when flow equals or exceeds 4000, but will not reset until the flow falls below 3900.

### 8.2.9 Alarm delay: 'dELA'

This function enables activation of the alarm output to be delayed for a fixed time following the alarm condition being detected. The delay can be programmed in 1 second increments up to 3600 seconds. If a delay is not required zero should be entered. To adjust the delay select 'dELA' from the alarm menu and press *P* which will reveal the existing delay time. Each digit of the delay can be adjusted using the *Up* and *Down* push-buttons, and the *P* button to move to the next digit. When the required delay has been entered, press *E* to return to the alarm menu.

The alarm annunciator will start flashing immediately an alarm is detected and continue for the delay time after which the alarm output will be activated.

### 8.2.10 Alarm silence time: 'SIL'

The alarm silence function is primarily intended for use in small installations where the alarm output directly operates an annunciator such as a sounder. When the alarm silence time is set to any figure other than zero, the *P* push-button becomes an alarm accept button.

After an alarm has occurred, operating the *P* button will cause the alarm output to revert to the non-alarm condition for the programmed alarm silence time. When an alarm is silenced the alarm annunciator will flash until the silence time expires.

To adjust the silence time select 'SIL' from the alarm menu and press *P* which will reveal the existing time. The time may be adjusted to between 0 and 3600 seconds in 1 second increments. Each digit can be adjusted using the *Up* and *Down* push-buttons, and the *P* button transfers control to the next digit. When the required time has been entered press *E* to return to the alarm menu.

### 8.2.11 Access Setpoint: 'AcSP'

This function activates a separate menu that provides direct access to the alarm setpoints when the instrument is in the display mode. See section 8.2.12 for a full description. An operator may therefore adjust the alarm setpoints without having access to the programme and alarm menus. Further protection is provided by a separate security code.

This direct access menu may be enabled and a separate security code entered from the 'AcSP' function in the main programme menu as shown in Fig 11. To change the menu parameters select 'AcSP' from the programme menu and press *P*. This will display the enable prompt 'EnbL'.

Press *P* again to reveal if the direct access menu is 'On' or 'OFF'. The *Up* or *Down* buttons will toggle the display between the two conditions.

If 'OFF' is selected, the operator will not have access to the setpoints from the display mode. Return to the 'AcSP' prompt in the main menu by pressing *E* twice.

If 'On' is selected, the operator will have direct access to the alarm setpoints from the display mode via a separate optional security code. To define this four digit numeric code press *E* to return to the 'EnbL' prompt followed by the *Up* or *Down* button to select the access code prompt 'AcCd'. Pressing *P* will then reveal the current security code. The flashing digit of the code may be changed by operating the *Up* or *Down* push-buttons and pressing the *P* button will transfer control to the next digit. When the required code has been entered, press *E* twice to return to the 'AcSP' prompt in the programme menu.

Entering code 0000 will disable the security code allowing direct access to the setpoints in the display mode by pressing the *P* and *Up* buttons simultaneously.

New instruments with alarms are supplied with the security code set to 0000

### 8.2.12 Adjusting alarm setpoints from the display mode

Access to the two alarm setpoints from the indicator display mode is obtained by operating the *P* and *Up* push-buttons simultaneously as shown in Fig 12. If the setpoints are not protected by a security code the alarm setpoint prompt 'SPr1' or 'SPt1' will be displayed depending upon whether a rate or total alarm

has been programmed. If the setpoints are protected by a security code, 'COde' will be displayed first. Pressing *P* again will enable the alarm security code to be entered digit by digit using the *Up* and *Down* buttons to change the flashing digit and the *P* push-button to move control to the next digit. If the correct code is entered pressing *E* will then cause alarm setpoint prompt 'SPx1' to be displayed. If an incorrect security code is entered, or a button is not pressed within ten seconds, the instrument will automatically return to the display mode.

Once within the menu pressing the *Up* or *Down* buttons will toggle the display between the two alarm setpoint prompts 'SPx1' and 'SPx2'.

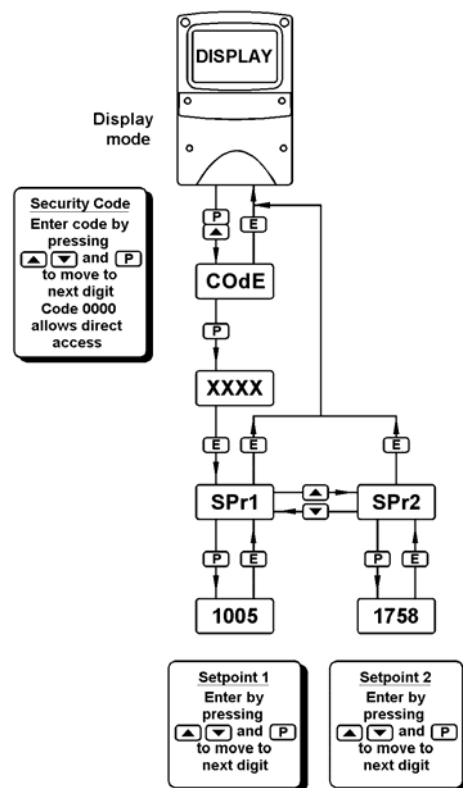

Fig 12 Setpoint adjustment from the display mode

To adjust an alarm setpoint select 'SPx1' or 'SPx2' and press *P* which will reveal the current setting. Each digit of the setpoint may be adjusted using the *Up* and *Down* push-buttons, and the *P* button to move control to the next digit. When the required setpoint has been entered, pressing *E* will return the display to the 'SPx1' or 'SPx2' prompt from which the other setpoint may be selected, or the indicator may be returned to the display mode by pressing *E* again.

**Note:** Direct access to the alarm setpoints is only available when the menu is enabled - see section 8.2.11

### **8.3 External push-buttons**

For applications requiring frequent access to the programme menus the BA544D can be supplied with an external membrane keypad. These switches, which maintain the IP66 integrity of the enclosure, allow all functions to be controlled without removing either of the enclosure covers.

### **8.4 Pipe mounting kits**

Two pipe mounting kits are available for securing the BA544D to a horizontal or vertical pipe.

BA392D Stainless steel bracket secured by two worm drive hose clips for 60 to 80mm outside diameter pipes.

BA393 Heavy duty stainless steel bracket secured by a single 'V' bolt. Will clamp to any pipe with an outside diameter between 40 and 80mm.

### **8.5 Stem mounting kit**

The BA395 stem mounting kit comprises a short length of stainless steel conduit with a male M20 x 1.5 thread at both ends. Allows the BA544D to be mounted directly onto a flow transmitter.



## 9. INDEX

Subject	Section	Subject	Section
'AcSP'	8.2.2; 8.2.11	'InPut'	5.5
Alarms optional	8.2	Installation	4.2
access	8.2.2; 8.2.11	Instrument identification	8.1
output status	8.2.2; 8.2.7		
delay time	8.2.2; 8.2.9	'LOC.rSEt'	5.13
enable	8.2.2; 8.2.3	Local reset	5.13
function	8.2.2; 8.2.6	Location	4.1
hysteresis	8.2.2; 8.2.8	Lower display	5.7
programming	8.2.2		
setpoint	8.2.2; 8.2.5	Maintenance	7.0
silence time	8.2.2; 8.2.10	routine	7.4
solid state output	8.2.1	Mounting kits	
type	8.2.2; 8.2.4	pipe	8.4
		stem	8.5
Battery BA491		'no.nc'	8.2.2; 8.2.7
conditioning	4.4; Appendix 1	Push-buttons	
disposal	4.5	<i>Down</i>	2.1
installation	4.4	<i>E</i>	2.1
life	2.3; 5.4; 8.2	<i>P</i>	2.1; 8.2.10
'bAtt'	2.3, 5.4	<i>Up</i>	2.1
		External optional	8.3
Calibration		Rate	
structure	5.1; Fig 7	display	2.2
programme access	5.2	scale factor	5.8
example	6.1	filter	5.10
'CLIP-OFF'	5.12	Reset	
Clipoff	5.12	local	5.13
'CodE'	5.15	remote	3.3
Decimal points	5.6	'SCALE-r'	5.8
'dELA'	8.2.2; 8.2.9	'SCALE-t'	5.11
Display	2.2	Security code	5.15
exchange rate & total	5.6	Servicing	7.3
update interval	5.4	'SIL'	8.2.2; 8.2.10
'DISPLAY.2'	5.7	'SPxx'	8.2.2; 8.2.5
'd.P.'	5.6		
'EnbL'	8.2.2; 8.2.3	't-bASE'	5.9
Fault finding		Terminal numbers	Fig 4
during commissioning	7.1	Timebase	5.9
after commissioning	7.2	Total	
'FILtEr'	5.10	display	2.2
Flow indicator	2.2	scale factor	5.11
Grand total	2.2	'tYPE'	8.2.2; 8.2.4
clear	5.14	Type of input	5.5
Guarantee	7.5	Units of measurement	8.1
'HI.LO'	8.2.2; 8.2.6	'UpdAtE'	5.4
'HStr'	8.2.2; 8.2.8		

## Appendix 1 BA491 Replacement Battery

### A1.0 BA491 battery

The BA491 is a component approved replacement battery for use in BEKA associates intrinsically safe and safe area products.

At 20°C the BA491 battery only loses about one percent of its charge each year allowing replacement batteries to be stored on-site. Because of this long shelf life and the very small current consumed by the BA544D rate totaliser replacement batteries should be conditioned before being installed.

### A1.1 Battery conditioning

When not being used an insulating oxide layer forms on the internal battery electrodes that prevents self-discharge and results in the very long battery shelf life. The very small current consumed by the BA544D rate totaliser may not be sufficient to quickly break down this oxide layer which will result in the instrument not functioning immediately it is switched on. When a replacement battery is fitted, or when the rate totaliser is turned on after not being used for an extended period, the battery should be conditioned by drawing a relatively large current from it for about thirty seconds to break down the oxide layer.

Do not leave the resistor connected as this will discharge the battery and shorten its life.

The amount of current drawn is not critical, carefully plugging a resistor with a value between 0 and 50ohms into the battery output terminals for about thirty seconds will break down the oxide layer and condition the BA491 battery – see Fig A1.

A 27ohm resistor is supplied with all replacement BA491 batteries.

### A1.2 Disposal of used batteries

The BEKA BA491 battery contains Lithium Thionyl Chloride cells that should not be included with standard industrial waste or incinerated.

More information about disposal is available from The British Battery Manufacturers Association [www.rebat.com](http://www.rebat.com)

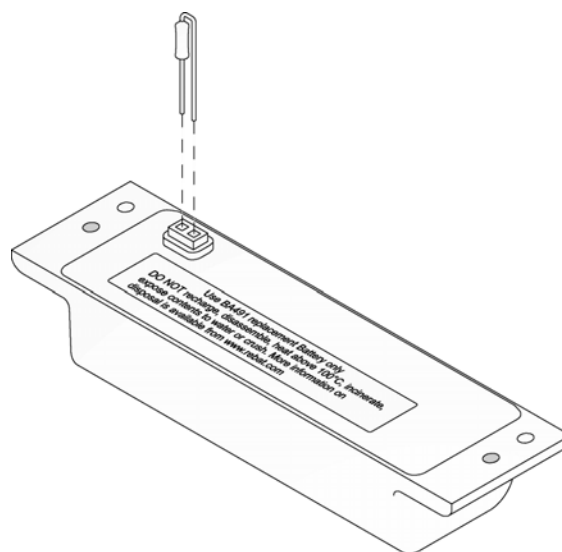

Fig A1 Conditioning BA491 battery by plugging a resistor into the output terminals for about 30 seconds.