

BA394 PANEL MOUNTING KIT FOR 'C' FIELD MOUNTING INSTRUMENTS

ASSEMBLY INSTRUCTIONS

Each panel mounting kit consists of the following components:

- 2 off Z-fixing bracket
- 4 off M6 captive bush
- 4 off M5 x 25 screw
- 4 off M5 nut
- 4 off M5 washer
- 4 off M6 x 25 screw
- 4 off M6 washer

- 1 The panel cut-out and the position of the fixing holes are shown in Figure A.
- 2 Remove the front of the instrument by unscrewing the four corner captive screws. Using the M5 screws, nuts and washers attach the Z-fixing brackets to the back of the instrument as shown in Figure B.
- 3 Push the four captive bushes into the 12.7 mm diameter holes in the Z-fixing brackets as shown in Figure B.
- 4 Offer the assembly to the panel and fix the brackets and trim plate to the panel using the M6 screws and washers.

FIGURE A

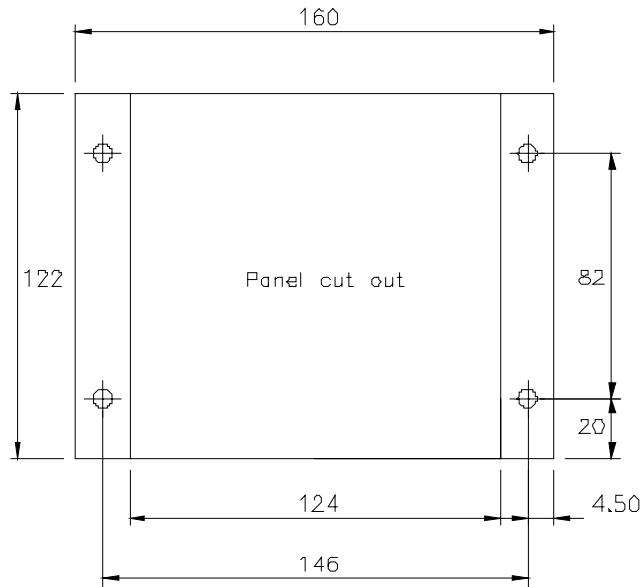
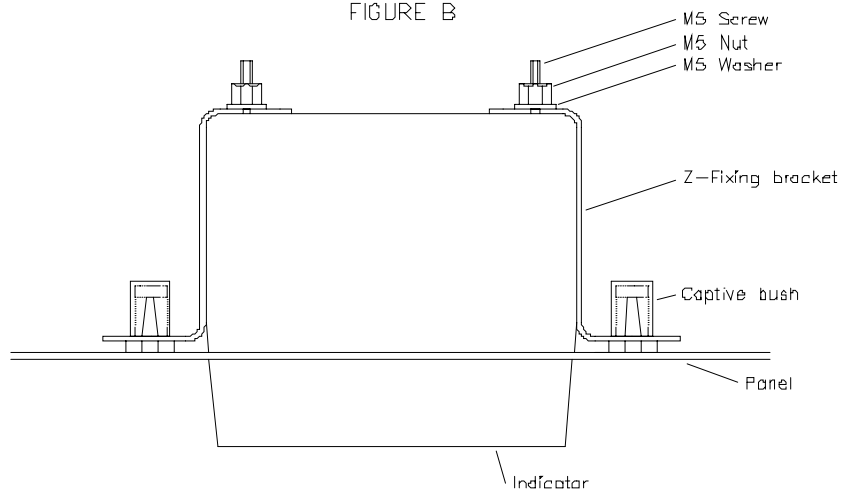

FIGURE B



ALL DIMENSIONS IN MM

BEKA associates Ltd Old Charlton Road, Hitchin, Herts. SG5 2DA
Tel: +44(0)1462 438301 Fax: +44(1)1462 453971 e-mail sales@beka.co.uk
www.beka.co.uk