

BA334ND
Type nL certified
externally powered
pulse input
field mounting
rate totaliser

Issue 13

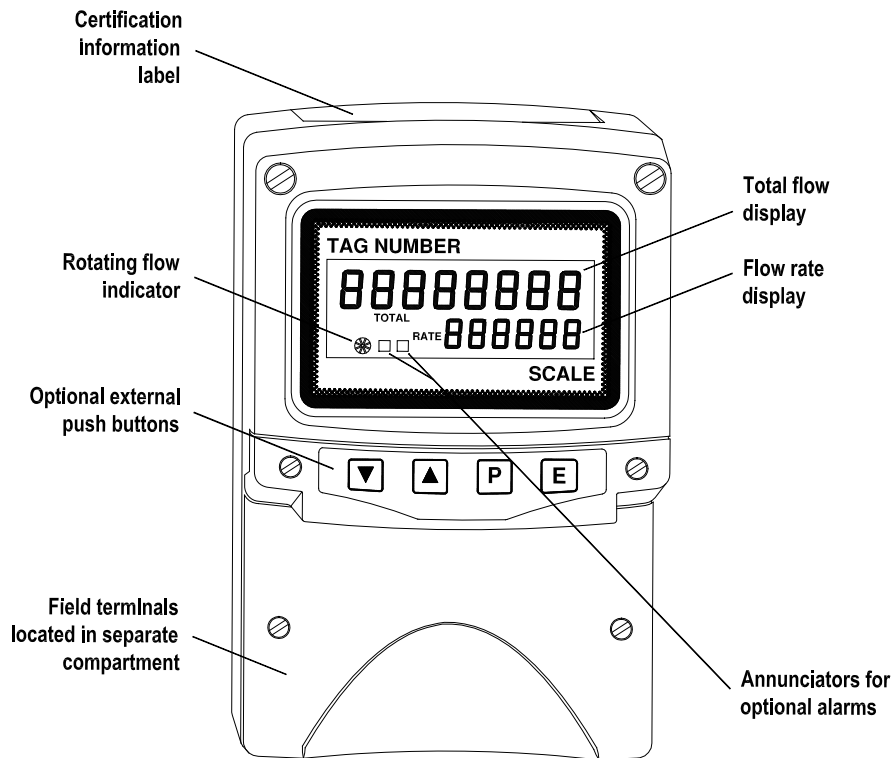

CONTENTS

1. Description

2. Operation

- 2.1 Initialisation
- 2.2 Controls
- 2.3 Displays

3. Type nL Certification

- 3.1 Certificate of Conformity
- 3.2 ATEX certification
- 3.3 Power supply
- 3.4 Pulse input terminals
- 3.5 Remote reset terminals
- 3.6 Zones, gas groups and T rating
- 3.7 Certification label information

4. System Design for Zone 2

- 4.1 Flow transmitter loop
- 4.2 Power supply
- 4.3 Pulse input
- 4.4 Remote reset

5. Installation

- 5.1 Location
- 5.2 Installation procedure
- 5.3 EMC

6. Programming and Calibration

- 6.1 Calibration structure
- 6.2 Accessing programme functions
- 6.3 Summary of programmable functions.
- 6.4 Display update interval
- 6.5 Type of input
- 6.6 Position of the decimal points
- 6.7 Lower display
- 6.8 Rate scale factor
- 6.9 Timebase
- 6.10 Rate filter
- 6.11 Total scale factor
- 6.12 Clip-off
- 6.13 Local reset
- 6.14 Resetting grand total
- 6.15 Security code

7. Calibration Example

- 7.1 Calibration procedure

8. Maintenance

- 8.1 Fault finding during commissioning
- 8.2 Fault finding after commissioning
- 8.3 Servicing
- 8.4 Routine maintenance
- 8.5 Guarantee
- 8.6 Customer comments

9. Accessories

- 9.1 Units of measurement and instrument identification.
- 9.2 Alarms
 - 9.2.1 Solid state output
 - 9.2.2 Type nL certification
 - 9.2.3 Programming and adjustment
 - 9.2.4 Alarm enable
 - 9.2.5 Type of alarm
 - 9.2.6 Setpoint adjustment
 - 9.2.7 Alarm function
 - 9.2.8 Alarm output status
 - 9.2.9 Hysteresis
 - 9.2.10 Alarm delay
 - 9.2.11 Alarm silence time
 - 9.2.12 Access setpoint
 - 9.2.13 Adjusting alarm setpoints from display mode.
- 9.3 Display backlight
- 9.4 Pulse output
- 9.5 4/20mA output
 - 9.5.1 Programming & adjustment
- 9.6 External push-buttons
- 9.7 Pipe mounting kits
- 9.8 Stem mounting kit

10. Index

The BA334ND is CE marked to show compliance with the
European Explosive Atmospheres Directive 94/9/EC
and the European EMC Directive 2004/108/EC

1. DESCRIPTION

The BA334ND is an Ex nL certified, externally powered pulse input rate totaliser primarily intended for use with flowmeters. The instrument simultaneously displays the rate of flow and the total flow in engineering units on two separate displays.

The BA334ND complies with the European ATEX Directive 94/9/EC for Group II, Category 3G equipment.

Housed in a robust IP66 glass reinforced polyester (GRP) enclosure with an armoured glass window, the BA334ND is surface mounting, or may be pipe mounted using one of the accessory kits. A stem mounting kit is also available allowing direct mounting onto a flowmeter conduit entry.

2. OPERATION

Fig 1 shows a simplified block diagram of a BA334ND. The instrument accepts pulses from a single source and after scaling displays the total number of pulses received and their rate on separate displays. When connected to a pulse output flowmeter the BA334ND will provide an accurate display of total flow and the rate of flow.

The BA334ND has two sets of input terminals for connection to high or low level voltage pulses, a switch contact, an open collector output or to a two wire proximity detector. The instrument may therefore be used with almost any type of pulse output flowmeter. The total display may be reset to zero by a remote switch contact, the internal switches or via the optional keypad on the outside of the instrument.

Optional accessories enable the flow rate to be transmitted to other equipment as an isolated 4/20mA analogue signal and the total flow to be transmitted as a pulse signal. Optional alarms, which may be programmed to function on the rate or total displays, further extend the instrument's applications.

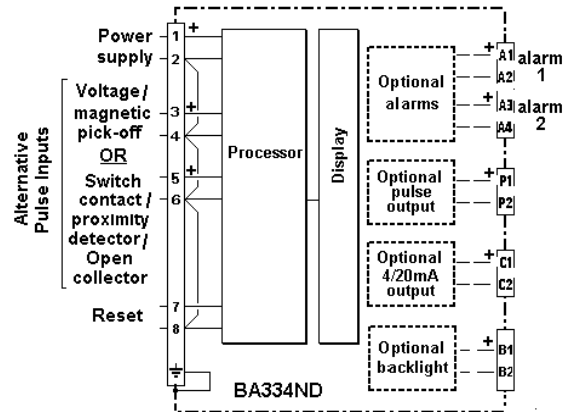

Fig 1 Simplified block diagram of BA334ND

2.1 Initialisation

Each time power is applied to the instrument initialisation is performed. After a short delay the following display sequence occurs:

All segments of the display are activated for 2 seconds.

The product firmware part number and version number are displayed for 2 seconds.

Rate display and totaliser start to function using calibration information stored in the instrument's permanent memory.

2.2 Controls

The BA334ND is controlled and calibrated via four push-button switches which are located behind the instrument control cover, or as an option on the outside of the instrument cover. In the display mode i.e. when the instrument is displaying rate and total flow the switch functions are:

Description of Switch Functions

E+ Down While these buttons are pushed the total display will show the least significant eight digits of the grand total, and the grand total annunciator will be activated.

E+ Up While these two buttons are pushed the total display will show the most significant eight digits of the grand total and the grand total annunciator will be activated.

**Down
+Up** Resets the total display to zero when these two push-buttons are operated simultaneously for two seconds. Selectable function from programme menu. See section 6.12

**Down
+P** While these buttons are pushed the instrument will display the firmware part number and version number.

Note: When optional alarms are fitted the push-buttons may be programmed to have alternative functions – see section 9.2

2.3 Displays

The BA334ND has two digital displays and associated annunciators, plus a flow indicator. See illustration on page 1.

**Rate
Display** Shows the flow rate on the smaller six digit display.

**Total
display** Shows the total flow on the larger eight digit display. Set to zero when local or remote reset switch is operated.

**Flow
indicator** This disc in the lower left hand corner of the display 'rotates' for two seconds each time an input pulse is received. Therefore when the pulse input frequency exceeds 0.5Hz the disc appears to rotate continuously.

**Hold
Annunciator** Activated when input frequency is below the clip-off threshold.

**Reset
Annunciator** Activated while instrument is being reset.

3. TYPE 'nL' CERTIFICATION

3.1 Certificate of Conformity

ITS Testing and Certification Ltd. (Formerly ERA Technology Ltd) have issued a Certificate of Conformity Ex01Y4014 confirming that the BA334ND complies with the CENELEC standard BS EN50021:1999.

The L suffix indicates that the Type n certified equipment uses an energy limiting technique based on the philosophy of intrinsic safety.

3.2 ATEX certification

The BA334ND complies with the European ATEX Directive 94/9/EC for Group II, Category 3G equipment. It has been assessed using the 'Internal Control of Production' procedure specified in Annex 8 of the Directive. A technical dossier has been prepared and an EC Declaration of Conformity BEKA01ATEX0012 has been issued.

The instrument bears the Community Mark and, subject to local codes of practice, may be installed in any of the EU member countries, i.e. Austria, Belgium, Denmark, Finland, France, Germany, Greece Ireland, Italy, Luxembourg, The Netherlands, Portugal, Spain, Sweden and the United Kingdom. ATEX certificates are also accepted in Norway, Iceland, Liechtenstein and in Switzerland.

This manual describes installations that comply with EN60079: Part 14 Electrical Installation in Hazardous Areas. When designing systems for installation outside the UK, the local Code of Practice should be consulted.

3.3 Power supply

The BA334ND certificate specifies the maximum input parameters for the power supply terminals 7 and 8.

$$\begin{aligned} U_i &= 30\text{V dc} \\ I_i &= 100\text{mA dc} \end{aligned}$$

When installed in Zone 2 the BA334ND must be powered from a supply with an output between 10 to 30V dc.

3.4 Pulse input terminals

The BA334ND rate totaliser has two alternative pairs of input terminals enabling the instrument to count pulses from a wide variety of sources. Terminals 3 and 4 are for connection to voltage pulse sources and terminals 5 and 6 to sources requiring power such as switch contacts and proximity detectors.

Note: Only one pair of input terminals may be used at one time.

Maximum input parameters are:

$$\begin{aligned} U_i &= 30\text{V dc} \\ I_i &= 100\text{mA dc} \end{aligned}$$

Input terminals 3 and 4 may therefore be connected to any voltage source providing that in normal operation it does not exceed the specified input figures. This is not restrictive and allows the BA334ND to be used with almost any voltage source.

Terminals 5 and 6 are for connection to a switch contact or a 2-wire NAMUR proximity detector. These do not contain a source of voltage and therefore there are no limits, although if installed in Zone 2 the proximity detector should be Type n approved.

3.5 Remote reset terminals

The BA334ND certificate specifies maximum input parameters for the external reset terminals 7 and 8:

$$\begin{aligned} U_i &= 30\text{V dc} \\ I_i &= 100\text{mA dc} \end{aligned}$$

These terminals are intended for connection to a switch contact in the safe or hazardous area, so normally input parameters do not have to be considered.

Note: The BA334ND may also be programmed so that the total display is reset to zero when the *Up* and *Down* push-buttons are operated simultaneously for more than two seconds.

3.6 Zones, gas groups and T rating

The BA334ND has been certified as Group II, Category 3G apparatus as defined in the ATEX Directive and as Ex nL T5, Tamb -40 to 60°C to EN 60079-15.

'L' indicates that the BA334ND uses energy-limiting techniques to achieve compliance as defined in EN 60079-15. This technique is based on the philosophy of *intrinsic safety* which limits the current and voltage applied to components which may generate a spark in normal operation. e.g. switches and potentiometers.

These approvals confirm that the BA334ND is safe in normal operation and may be installed in:

Zone 2 hazardous area

Be used with gases in groups:

Group A propane
Group B ethylene
Group C hydrogen

Having a temperature classification of:

T1 450°C
T2 300°C
T3 200°C
T4 135°C
or T5 100°C

At an ambient temperature between -20 and +60°C

This allows the BA334ND to be installed in Zone 2 hazardous areas (low risk) and to be used with most common industrial gases.

3.7 Certification Label Information

ATEX certification information is shown on a label fitted in a recess on the top outer surface of the enclosure. The instrument serial number and date of manufacture are recorded on a separate label inside the terminal compartment.



4. SYSTEM DESIGN FOR ZONE 2

4.1 Flow transmitter loops

The BA334ND may be connected to almost any pulse output flowmeter and calibrated to display rate of flow and total flow in the same or different engineering units.

Fig 2 illustrates the basic circuit that is used for all BA334ND installations. For simplicity, connections for the optional pulse output, 4/20mA output and backlight are included in section 9 of this manual.

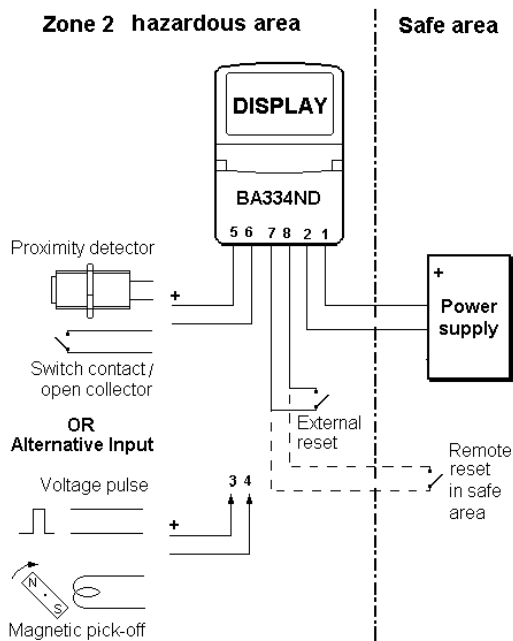

Fig 2 BA334ND in flow application

When designing a system it is important to remember that terminals 2, 4, 6 and 8 are interconnected within the BA334ND - see Fig 1. All wiring, transducers and the power supply must be able to withstand a 500V rms insulation test to earth for one minute. If the system is to be connected to earth this should only be done at one point within the safe area, for example at the negative terminal of the power supply. See EN60079-14 for guidance.

4.2 Power supply

The BA334ND may be powered from any dc supply having an output voltage between 10 and 30V. The instrument consumes about 12mA rising to 15mA when a proximity detector input is used.

To comply with the Ex nL certification requirements, the power supply output must not exceed 30V dc and 100mA dc in normal operation.

4.3 Pulse input

As shown in Fig 2, the BA334ND will count pulses from a wide variety of transducers enabling it to display the output from almost any flowmeter.

The instrument has one pulse input, but two sets of input terminals enable it to accommodate different types of transducers. Terminals 3 and 4 are for voltage pulse inputs and terminals 5 and 6 are for pulse sources that need powering such as switch contacts and proximity detectors.

Note: Only one pair of input terminals may be used at a time. i.e pulses can not be counted from terminals 3 & 4 and from terminals 5 & 6 at the same time.

The following table shows the switching thresholds for the various transducers, plus the maximum operating frequency and the input terminal numbers. For reliable counting the input signal must fall below the lower threshold and rise above the upper threshold.

	Switching thresholds		Freq max	Input terminals
Switch	100Ω	1000Ω	100Hz	5 & 6
Proximity detector	1.2mA	2.1mA	5 kHz	5 & 6
Open collector	2kΩ	10kΩ	5kHz	5 & 6
Magnetic pick-off	0mV	20mV peak	5kHz	3 & 4
Voltage pulse	1.0V	3.0V	5kHz	3 & 4

To comply with the Ex nL certification requirements, in normal operation the output from the pulse transducer must not exceed 30V dc and 100mA dc.

4.4 Remote reset

The BA334ND total display is reset to zero when terminals 7 & 8 are connected together for more than one second. Permanent interconnection of these terminals will stop totalisation and may be used as an inhibit function. There is no practical limit on the distance that the reset switch may be from the totaliser.

Alternatively, the BA334ND may be programmed so that the total display is reset to zero when the *Up* and *Down* push-buttons are operated simultaneously for more than two seconds. – see 6.12

5. INSTALLATION

5.1 Location

The BA334ND rate totaliser is housed in a robust IP66 glass reinforced polyester (GRP) enclosure incorporating an armoured glass window and stainless steel fittings. It is suitable for exterior mounting in most Zone 2 classified industrial environments, including off-shore and waste water treatment. Please consult BEKA associates if high vibration is anticipated.

The BA334ND enclosure is surface mounting. Accessory kits described in sections 9.7 & 9.8 of this manual enable the instrument to be mounted onto a vertical or horizontal pipe, or directly onto a flowmeter conduit entry.

The field terminals and the two mounting holes are located in a separate compartment with a sealed cover allowing the instrument to be installed without exposing the display assembly.

The BA334ND earth terminal is connected to the internal EMC filters. For maximum radio frequency interference rejection this terminal should be connected to a local earth, or to a cable screen which is earthed in the safe area. The BA334ND enclosure is supplied with a bonding plate to ensure electrical continuity between the three conduit / cable entries.

5.2 Installation Procedure

Fig 3 illustrates the instrument installation procedure.

- a. Remove the instrument terminal cover by unscrewing the two captive 'A' screws.
- b. Mount the instrument on a flat surface and secure with two M6 screws through the 'B' holes. Alternatively use one of the mounting kits described in section 9.7 and 9.8
- c. Remove the temporary hole plug and install an Ex n or Ex e cable gland or conduit entry. If more than one entry is required, replace one or both IP66 stopping plugs with an Ex n or Ex e cable gland or conduit entry.
- d. Connect the field wiring to the instrument terminals as shown in Fig 4.
- e. Replace the instrument terminal cover and evenly tighten the two 'A' screws.

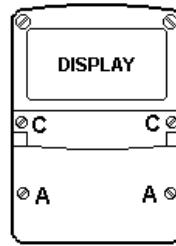

Step a

Remove the terminal cover by unscrewing the two 'A' screws

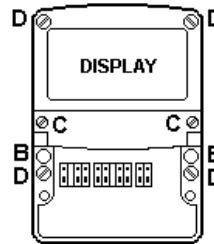

Step b

Secure the instrument to a flat surface with screws through the two 'B' holes. Alternatively use a pipe mounting kit.

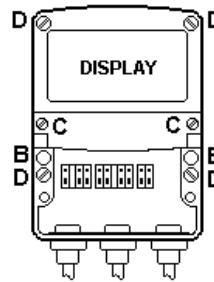

Steps c, d and e

Remove temporary hole plug and install Ex n or Ex e cable gland or conduit fitting. If more than one entry is required, one or two of the IP66 stopping plugs should be replaced with an Ex n or Ex e cable gland or conduit fitting. Replace the terminal cover and tighten the two 'A' screws.

Fig 3 BA334ND installation procedure

5.3 EMC

The BA334ND complies with the requirements of the European EMC Directive 2004/108/EC. For specified immunity all wiring should be in screened twisted pairs and the BA334ND earth terminal should be locally earthed or connected to a cable screen which is earthed in the safe area.

To prevent circulating currents, cable screens should only be earthed at one point in the safe area.

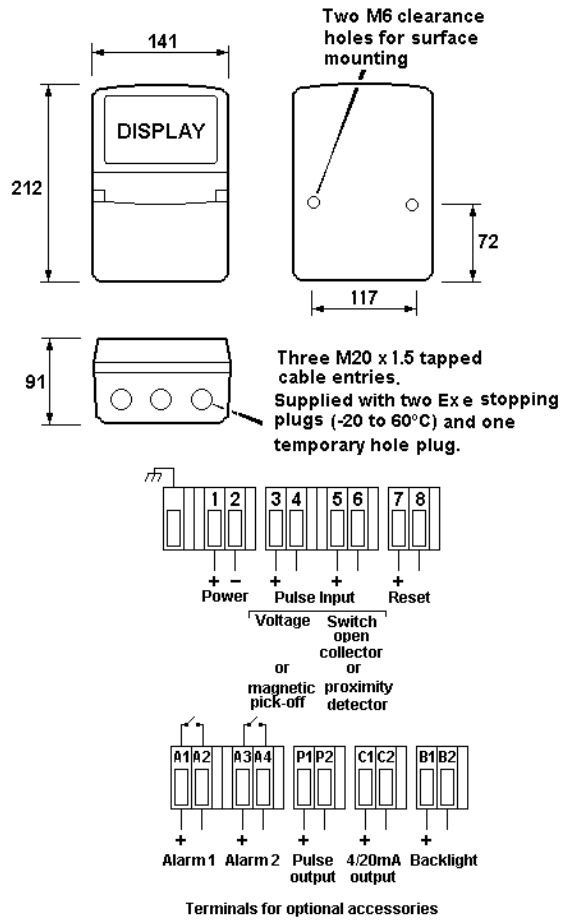

Fig 4 Dimensions and terminal connections

6. PROGRAMMING & CALIBRATION

The BA334ND is programmed and calibrated via four push-buttons which are located behind the instrument control cover. If frequent access to the push-buttons is required, the rate totaliser can be supplied with duplicate membrane push-buttons mounted on the outside of the control cover.

All the programming functions are contained in an easy to use menu that is shown diagrammatically in Fig 6. Each function is summarised in section 6.3 which includes references to more detailed information. Although this simple menu driven system enables most adjustments to be made without repeated reference to this manual, it is recommended that at least the summary of the programmable functions in section 6.3 is read before attempting programming or recalibration.

When the BA334ND is fitted with alarms, a pulse or 4/20mA output, the basic menu is expanded to include the option(s). Section 9 of this manual explains how to programme these additional functions.

Note: While the instrument is being programmed, totalisation continues so that any flow occurring during this time is recorded.

6.1 Calibration structure

Fig 5 shows the BA334ND calibration structure. The rate and total display calibration functions are totally independent allowing the displays to have different engineering units.

For the rate display the pulse input is divided by SCALE-r to represent engineering units and multiplied by the timebase t-bASE to calculate and display the rate of flow per second, minute or hour.

Similarly, to calculate the total flow in engineering units the number of input pulses is divided by the total scale factor SCALE-t. Total flow is continuously added to the grand total.

The BA334ND displays 'real' decimal points. Moving the position of a decimal point in a scale factor will therefore affect the instrument calibration.

The BA334ND updates its total flow calculation twice per second. If the instrument is used for batching applications, this resolution may define the accuracy of the system.

Note: The total and rate displays may be updated less frequently depending upon the display update time selected.

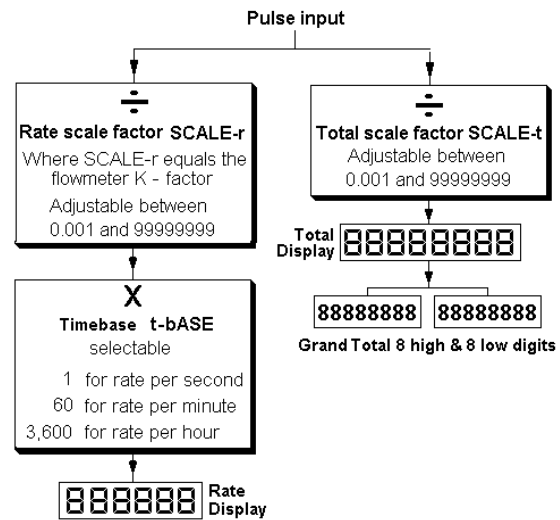

Fig 5 Calibration structure

6.2 Accessing programming functions

Throughout this manual push-buttons are shown in italics e.g. *P* or *Up* push-button, and legends displayed by the instrument are shown within inverted commas e.g. 'CAL' and 'ALr2'.

Access to the programme menu is obtained by operating the *P* and *E* push-buttons simultaneously. If the instrument is not protected by a security code the first parameter 'UPdAtE' will be displayed. If a security code other than the default code 0000 has already been entered, the instrument will display 'COdE'. Press *P* to clear this prompt and enter the security code for the instrument using the *Up* or *Down* push-buttons to adjust each digit, and the *P* push-button to move control to the next digit. If the correct code has been entered pressing *E* will cause the first parameter 'UPdAtE' to be displayed. If an incorrect code is entered, or a push-button is not operated within ten seconds, the instrument will automatically return to the display mode.

Apart from defining the position of the decimal point in the rate display, all programme functions and prompts are shown on the large eight digit display.

Once within the main programme menu the required parameter can be reached by scrolling through the menu using the *Up* and *Down* push-buttons as shown by the programme structure in Fig 6.

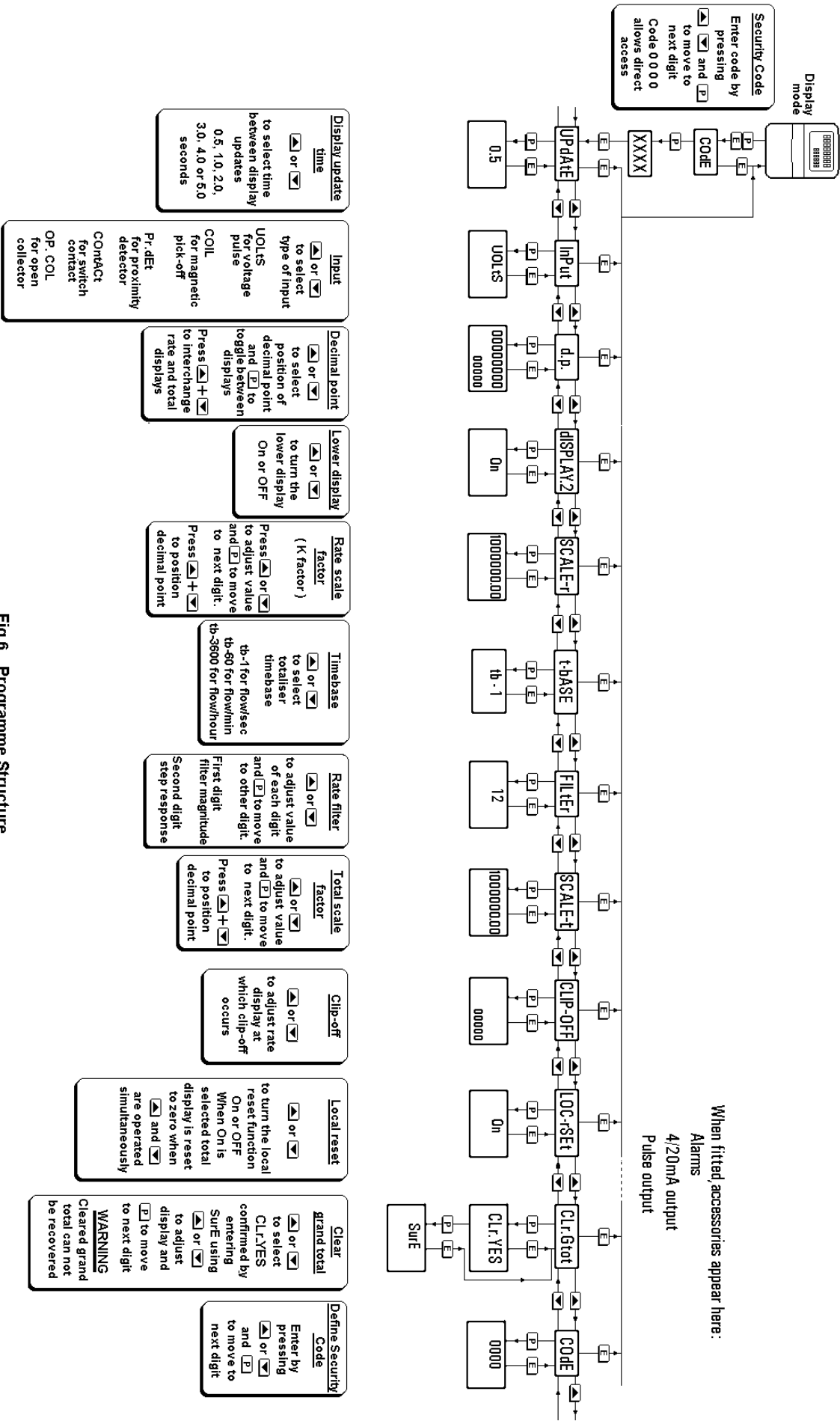

Fig 6 Programme Structure

All new BA334ND rate totalisers are supplied calibrated as requested at the time of ordering. If calibration information is not supplied, the instrument will be conditioned for an open collector input, with SCALE-r and SCALE-t set to 1 with a timebase of seconds.

6.3 Summary of programmable functions

This section summarises all the programmable functions. When read in conjunction with Fig 6 it provides a quick aid for programming the instrument. If more detail is required, each section contains a reference to a full description of the function.

SUMMARY

<u>Display</u>	<u>Description of function</u>
'UpdAtE'	Display update time Allows the interval between display updates to be selected. See section 6.4
'InPut'	Type of input Enables one of five types of input to be selected: UOLtS Voltage pulse COIL Magnetic pick-off Pr.dEt NAMUR proximity detector. COntACt Switch contact OP.COL Open collector See section 6.5
'd.P.'	Decimal points Defines the position of the decimal point in both the rate and total displays and enables the rate and total displays to be interchanged. See section 6.6
'dISPLAY.2'	Lower display Turns lower display, which normally shows rate, on or off. See section 6.7

Display Description of function

'SCALE-r' Rate scale factor

Defines the arithmetic relationship between the pulse input frequency and the rate display. May be adjusted between 0.001 and 99999999.

When used with a flowmeter, SCALE-r should be set to the flowmeter K factor (pulses per unit of measurement) if the display is required in the same units as the K factor.

See section 6.8

't-bASE' Timebase

Selectable multiplier to display flow rate in units per second, per minute or per hour.

Select:

tb-1	for flow / second
tb-60	for flow / minute
tb-3600	for flow / hour

See section 6.9

'FILtEr' Rate filter

Adjustable digital filter to reduce noise on the rate display. Two parameters each adjustable between 0 and 9.

See section 6.10

'SCALE-t' Total scale factor

Defines the arithmetic relationship between the number of input pulses and the total display.

May be adjusted between 0.001 and 99999999.

When used with a flowmeter SCALE-t should be set to the flowmeter K factor (pulses per unit of measurement) if the display is required in the same units as the K factor.

See section 6.11

'CLIP-OFF' Clip off

To prevent the totalisation of very low flow rates, clip-off enables the user to select a flow rate below which totalisation is inhibited.

See section 6.12

Display **Description of function**

'LOC.rSEt' Local reset of total display

When turned 'On' the total display may be reset to zero from the display mode by simultaneously operating the *Up* and *Down* push-buttons for two seconds.
See section 6.13

'CLr. Gtot' Clears grand total

This function resets the grand total to zero when 'CLr YES' is selected, and 'SurE' is entered to confirm the instruction.

Note: Once cleared, a grand total can not be recovered.
See section 6.14

'COdE' Security code

Defines a four digit numeric code which must be entered to gain access to the programmable functions. Default code 0000 disables the security function and allows unrestricted access to all programmable functions.
See section 6.15

'UOLts' Voltage pulse input
Threshold 1V and 3V
5kHz max.
Input terminals 3 and 4

'COIL' Low voltage pulse
Threshold 20mV
peak, 5kHz max.
Input terminals 3 and 4

'Pr.dEt' NAMUR proximity detector
Threshold 1.2 and 2.1mA
5kHz max.
Input terminals 5 and 6

'COntACT' Switch contact
Threshold 100 and 1000Ω
100Hz max
Input terminals 5 and 6

'OP.COL' Open collector
Threshold 2kΩ and 10kΩ
5kHz max.
Input terminals 5 and 6

When the required type of input has been selected press *E* to return to the main menu.

Note: To count correctly, the input signal must fall below the lower switching threshold and rise above the higher switching threshold.

6.4 Display update interval: 'UpdAtE'

Six different intervals between display updates varying between 0.5 and 5 seconds may be selected. If either the rate or the total displays are likely to change rapidly, a longer interval between updates may simplify reading the instrument display. The selected update interval does not affect the update time of any other instrument function such as the optional 4/20mA output.

To define the update interval select 'UpdAtE' from the main menu and press *P* to reveal the current time. Pressing the *Up* or *Down* button will scroll through the six times. When the required interval has been selected press *E* to return to the main menu.

6.5 Type of input: 'InPut'

The BA334ND may be programmed to accept pulse inputs from a wide variety of sensors. To define an input type select 'InPut' from the menu and press *P* which will reveal the current input type. Pressing *Up* or *Down* will scroll through the five options:

6.6 Position of the decimal points: 'd.P.'

The rate display can have up to six digits and the decimal point may be positioned between any of them, or omitted. Similarly, the total display has eight digits and the decimal point may be positioned between any of them, or may be omitted.

To adjust the position of either decimal point select 'd.P.' from the main menu and press *P*. This will activate both displays with one digit plus the following decimal point of the total display flashing. If only the least significant digit is flashing, this indicates that the decimal point is omitted.

The position of the decimal point can be moved by pressing the *Up* or *Down* push-button. Operating the *P* push-button will toggle control between the two displays. When both decimal points have been correctly positioned press *E* to return to the main menu.

If the application requires flow rate to be the primary display i.e. shown on the large display, the d.P. function enables the rate and total displays to be interchanged. The rate display will continue to have six digits but the total display will be reduced from eight to six digits.

The rate and total annunciators will also be interchanged. Pressing the *Up* and *Down* buttons simultaneously will interchange the displays.

Note: Both decimal points must be repositioned after the displays have been interchanged.

6.7 Lower display: 'dISPLAY.2'

This function turns the lower display on or off. When turned off, the BA334ND will only have one eight digit display which may be programmed to show total flow or rate of flow.

6.8 Rate scale factor: 'SCALE-r'

Together with the instrument timebase, this function defines the arithmetic relationship between the pulse input frequency and the rate display. When used with a flowmeter SCALE-r should be set to the K-factor of the flowmeter i.e. the number of pulses the flowmeter produces for a unit of flow. e.g. 45.6 pulses per litre. See section 7 for a worked example.

SCALE-r is a dividing factor that may be adjusted between 0.001 and 99999999.

To check or change the rate scale factor select 'SCALE-r' from the main menu and press *P* to reveal the existing setting, one digit will be flashing. The value of the flashing digit can be changed by pressing the *Up* or *Down* buttons. When this digit is correct pressing *P* will transfer control to the next digit.

To position the decimal point in the rate scale factor, move the flashing digit to the left hand side of the required decimal point position and simultaneously press the *Up* and *Down* buttons. When the required rate scale factor has been entered, press *E* to store the number and return to the main menu.

6.9 Timebase: 't-bASE'

The timebase multiplies the rate display by 1, 60 or 3,600 depending upon whether the BA334ND is required to display rate per second, per minute or per hour. See Fig 5.

To check or change the timebase, select 't-bASE' from the main menu and press *P* which will reveal the current setting. Pressing the *Up* or *Down* button will index through the three options:

tb-1	for flow / second
tb-60	for flow / minute
tb-3600	for flow / hour

Select the required multiplier and press *E* to return to the main menu.

6.10 Rate filter: 'FILtEr'

This digital filter has two independent adjustable parameters enabling the rate display frequency response to be tailored for optimum performance.

The filter parameters are controlled by a two digit number. The first digit defines the amount of filtering applied to the display as shown below.

First digit	Filter time constant seconds
0X	0
1X	1.3
2X	4.3
3X	6.5
4X	8.7
5X	11.3
6X	15.7
7X	20.9
8X	25.2
9X	31.5

The second digit defines the deviation from the displayed rate at which the filter will be overridden and the rate display will move rapidly to the new value.

Second digit	Magnitude of step change which will produce a rapid response
X0	Off
X1	1%
X2	2%
X3	4%
X4	8%
X5	12%
X6	16%
X7	24%
X8	32%
X9	64%

By careful adjustment of the two parameters a stable display with an acceptable step input response can be obtained for most applications.

During commissioning it is recommended that initially the second digit is set to 0 (off) and the first digit is adjusted to provide acceptable rate display stability. The second digit should then be increased until the selected step size is greater than the noise on the display signal, at which setting the rate display will again become stable. These will be the optimum filter parameters for acceptable rate display stability and a fast response to a large rate signal change.

To check or change the filter select 'FILtEr' from the main menu and press *P* to reveal the current settings. Pressing the *Up* or *Down* button will change the flashing digit and *P* will transfer control to the second digit. While making adjustments the filtered rate display is shown on the lower display so that stability can be assessed. When set as required, press the *E* button to enter the revised parameters and return to the main menu.

6.11 Total scale factor: 'SCALE-t'

This factor defines the arithmetic relationship between the number of input pulses and the total display. SCALE-t is a dividing factor that may be adjusted between 0.001 and 99999999. See Fig 5.

When used with a flowmeter SCALE-t should be set to the K-factor of the flowmeter i.e. the number of pulses the flowmeter produces for a unit of flow. If the BA334ND total display is required in units different from those in which the flowmeter K factor is specified, a conversion factor will be required.

e.g. If the flowmeter has a K factor of 45.6 pulses per litre and the BA334ND total display is required in units of 1,000 gallons, then SCALE-t should be set to number of pulses produced by the flowmeter per 1,000 gallons:

$$45.6 \times 4.54609 \times 1000$$

$$207,301.7 \text{ pulses per 1000 gallons}$$

(there are 4.54609 litres in a UK gallon)

To check or change the total scale factor select 'SCALE-t' from the main menu and press *P* to reveal the existing setting, one digit will be flashing. The value of the flashing digit can be changed by pressing the *Up* or *Down* buttons. When this digit is correct pressing *P* will transfer control to the next digit.

To position the decimal point in the scaling factor, move the flashing digit to the left hand side of the required decimal point position and simultaneously press the *Up* and *Down* buttons.

When the required total scale factor has been entered, press *E* to store the number and return to the main menu.

6.12 Clip-off: 'CLIP-OFF'

To prevent totalisation of very low flow rates that over long periods may result in significant

totalisation errors, the BA334ND may be programmed to stop totalising when the flow rate falls below an adjustable threshold.

To check or change the clip-off threshold select 'CLIP-OFF' from the main menu and press *P* which will reveal the current setting. The threshold is shown in the units already selected for the flow rate display. One digit will be flashing. The value of the flashing digit may be changed by pressing the *Up* or *Down* buttons. When this digit is correct pressing *P* will transfer control to the next digit. When clip-off is set as required, press the *E* button to enter the revised figure and return to the main programme menu.

If the flow rate falls below the entered threshold, the rate display will show zero flow, totalisation will stop and the HOLD annunciator will be activated. The flow indicator will rotate for 2 seconds each time an input pulse is received i.e. at input frequencies above 0.5Hz it will appear to rotate continuously.

Note: When the rate scale factor SCALE-r, the timebase t-bASE, or the position of the rate display decimal point are changed, clip-off will automatically be reset to zero. If required, a new clip-off threshold may then be entered.

6.13 Local reset of total display: 'LOC. rSEt'

When activated this function enables the operator to reset the BA334ND total display to zero in the display mode by operating the *Up* and *Down* push-buttons simultaneously for more than two seconds. To check the status of the local reset function select 'LOC.rSEt' from the menu and press *P* which will reveal if the function is 'On' or 'OFF'. If necessary press the *Up* or *Down* button to change the setting, followed by the *E* button to return to the main menu.

The total display may also be reset to zero remotely by connecting terminals 7 and 8 together. See section 3.5 of this manual.

6.14 Resetting grand total: 'CLr. Gtot'

The grand total is a separate sixteen digit counter which duplicates the total display but is not zeroed when the total display is reset to zero. The grand total may be viewed in the display mode in two eight digit sections as described in section 2.2 of this manual.

The grand total counter can only be reset to zero from the 'CLr. Gtot' function in the main programme menu. To zero the grand total

counter select 'CLr. Gtot' and press *P* which will cause the instrument to display 'Clr. no' with 'no' flashing. Continuously press the *Up* or *Down* push-buttons until 'CLr. YES' is displayed and then press *P* which will result in a 'CLr 0000' prompt with one digit flashing. Using the *Up* and *Down* buttons and the *P* button to move to the next digit, confirm the request by entering the password 'SurE'. Note 'S' is entered as '5'. Pressing *E* will then reset the grand total counter to zero and return the instrument to the 'CLr. Gtot' prompt in the main menu.

WARNING

After resetting the grand total counter to zero the old grand total can not be recovered.

6.15 Security code: 'CodE'

The calibration and conditioning of the instrument may be protected by a four digit security code which must be entered before access to the programme menu is granted. New instruments are programmed with the default security code 0000 which allows unrestricted access to all programming functions without entering a security code.

To enter a new security code select 'COdE' from the menu and press *P* which will cause the instrument to display the current security code. Each digit of the code can be changed using the *Up* and *Down* push-buttons, and the *P* button to move to the next digit. When the required code has been entered press *E* to return to the main menu. The revised security code will be activated when the indicator is returned to the display mode.

If the security code is lost, access to the programmable functions can be obtained by moving the internal security link to the override position. The original security code can then be viewed by selecting 'CodE' from the main menu and pressing *P*.

To gain access to the security code link, remove the instrument control cover by undoing the two 'C' screws – see Fig 7. If the instrument is fitted with external push-buttons the connecting ribbon cable should be unplugged from the outer row of the five pin connector. The security code override link is located on the inner row of the five pin connector.

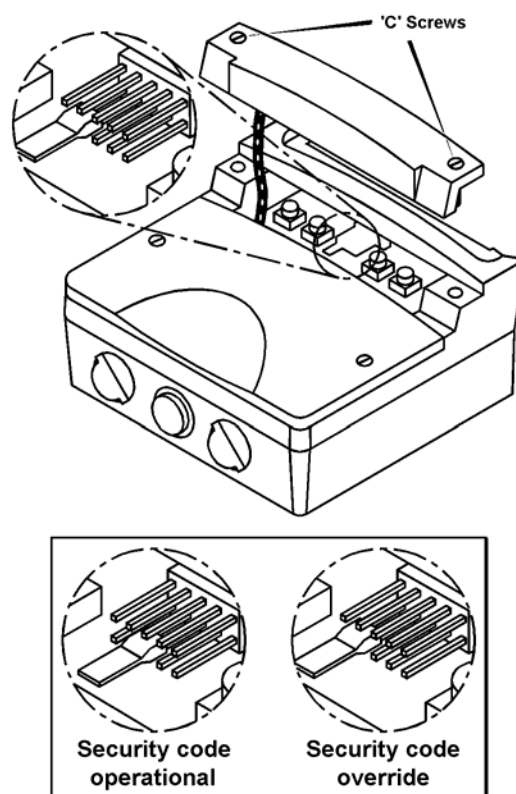

Fig 7 Location of security override link

7. CALIBRATION EXAMPLE

In this example a BA334ND rate totaliser is connected to a turbine flowmeter having a K-factor of 1050.0 pulses per litre. The flowmeter has a magnetic pick-off with an output greater than 20mV peak at 5 litres per minute and a usable range of 5 to 60 litres per minute.

The BA334ND is required to display rate of flow in litres per hour with a resolution of one litre and total flow in cubic metres with a resolution of 0.01 cubic metres. Totalisation is to stop when the flow rate falls below 300 litres per hour. The display is to be updated twice per second and filtering is required. In this application the operator needs to reset the total display to zero by simultaneously pushing the *Up* and *Down* push-buttons. To prevent tampering the instrument programme menu is to be protected by security code 1209

7.1 Calibration procedure

The BA334ND rate totaliser may be calibrated on-site without disconnection from the power supply or from the flowmeter. When installed in a Zone 2 hazardous area, calibration should only be performed when there is no risk of a flammable atmosphere being present and dust and water can not enter the enclosure.

Step 1 Enter the programming mode

Put the BA334ND in the programming mode by simultaneously pressing *P* and *E*. Assuming a security code has not already been entered the instrument will respond by displaying 'UPdAtE' which is the first function in the main menu. See Fig 6.

Step 2 Select the interval between display updates

With 'UPdAtE' displayed, press *P* to reveal the existing interval between display updates. If this is not as required, press the *Up* or *Down* button until '0.5' is displayed. (0.5 seconds i.e. 2 display updates per second). Enter the revised time and return to the 'UPdAtE' prompt in the main menu by pressing *E*.

Step 3 Select the type of input

Using the *Up* or *Down* button scroll through the main menu until 'InPut' is displayed, then press *P* to reveal the existing setting. Select 'COIL',

the input for a magnetic pick-off, using the *Up* or *Down* button and return to the 'InPut' prompt in the main menu by pressing *E*.

Note: The BA334ND has two pairs of input terminals. 3 & 4 for voltage inputs and 5 & 6 for switch contact, proximity detector or open collector inputs. Ensure that the magnetic pick-off that has a voltage output is connected to terminals 3 & 4.

Step 4 Position rate & total decimal points

Select 'd.P.' from the main menu and press *P*. The rate and total displays will be activated with one digit of the total display flashing. Press the *Up* or *Down* push-button until the third least significant digit of the total display and following decimal point are flashing. This gives the required total display resolution of 0.01

Press *P* to move control to the rate display. Using the *Up* or *Down* push-button move the flashing digit to the least significant position (right hand side) which will result in no decimal point being displayed. Finally press *E* to return to the 'd.P.' prompt in the main menu.

Step 5 Enter the rate scaling factor

Select 'SCALE-r' from the main menu and press *P* to show the current figure. The K factor of the flowmeter in this example is 1050.0* pulses per litre which should be entered as the rate scaling factor.

Firstly to position the decimal point, operate the *P* push-button to move the flashing digit to second least significant position. Pressing the *Up* and *Down* buttons simultaneously will then position the decimal point in front of the least significant digit.

Using the *Up* and *Down* buttons to adjust each digit in turn and the *P* button to transfer control between digits, enter 1050.0. Finally return to the 'SCALE-r' prompt in the main menu by pressing *E*.

* Could also be entered as 1050

Step 6 Enter the rate timebase

Select 't-bASE' from the main menu and press *P* to show the current setting. In this example the rate display is required in litres per hour. Using the *Up* or *Down* button scroll through the three options and select 'tb-3600' which will multiply the rate display by 3600. Return to the 't-bASE' prompt in the main menu by pressing *E*.

Step 7 Adjust the rate filter

The rate display filter parameters should be adjusted experimentally after installation to provide a stable rate display.

During commissioning it is recommended that initially the second digit of the rate filter parameters is set to 0 (step response off) and the first digit (amount of filtering) is adjusted to provide acceptable rate display stability. The second digit should then be increased until acceptable rate display stability is once again achieved.

To adjust the filter parameters select 'FILtEr' from the main menu and press *P* to reveal the current setting. The first digit will be flashing and may be adjusted using the *Up* or *Down* button. The *P* button will transfer control to the second digit. When both are set as required, return to the 'FILtEr' prompt in the main menu by pressing *E*.

Note: While adjusting the filter, the rate is shown on the lower display so that stability can be assessed.

Step 8 Enter the total scaling factor

The K factor of the flowmeter in this example is 1050.0 pulses per litre and the total display is required in cubic metres.

There are 1000 litres in a cubic metre so the BA334ND is required to display 1 cubic metre for every 1,050 x 1,000 pulses received. 'SCALE-t' should therefore be set to 1,050,000

Select 'SCALE-t' from the main menu and press *P* which will reveal

the current setting with one digit flashing. To position the decimal point, operate the *P* push-button to move the flashing digit to the least significant position. Pressing the *Up* and *Down* buttons simultaneously will then remove the decimal point.

Using the *Up* and *Down* buttons to adjust each digit in turn and the *P* button to transfer control between digits, enter 1050000. Finally return to the 'SCALE-t' prompt in the main menu by pressing *E*.

Step 9 Define clip-off

In this example totalisation is to be inhibited at flow rates below 300 litres per hour.

Select 'CLIP-OFF' from the main menu and press *P* which will reveal the clip-off threshold in litres per hour i.e. the same units already selected for the rate display. The most significant digit of the display will be flashing, indicating that this digit may be adjusted. Pressing *P* five times will move the flashing digit to the third least significant digit.

Using the *Up* and *Down* buttons set the third least significant digit to 3 i.e. a clip-off threshold of 300. Finally return to the 'CLIP-OFF' prompt in the main menu by pressing *E*.

Step 10 Turn local reset on

In this example the operator needs to reset the total display to zero by pressing the *Up* and *Down* buttons simultaneously. To activate the local reset function select 'LOC.rSEt' from the main menu and press *P* to display the current setting. Pressing the *Up* or *Down* button will toggle the display between 'On' and 'OFF'. Select 'On' and press *E* to return to the 'LOCrSEt' prompt in the main menu.

Step 11 Reset the grand total to zero

Before completing commissioning the grand total counter should be reset to zero. Select 'CLr. Gtot' from the main menu and press *P* which will cause the instrument to display 'Clr. no'. Toggle this to 'CLr. YES' using the *Up* or *Down* push-buttons and press *P* which will result in a '0000' prompt. Using the *Up*, and *Down* buttons and the *P* button to move to the next digit, confirm the request by entering the password 'SurE'. Note: S is entered as 5. Pressing *E* will then reset the grand total counter to zero and return the instrument to the 'CLr. Gtot' prompt in the main menu.

Step 12 Define the security code

Defining a security code prevents unauthorised access to the programme functions. Select 'COdE' from the main menu and press *P* which will reveal the existing security code. Using the *Up* and *Down* buttons enter the new code 1209 digit by digit. The *P* button will transfer control between digits. When the new code has been entered, press *E* to return to the main programme menu.

Step 13 Return to the display mode

Following completion of programming and calibration, return the BA334ND to the operating mode by pressing *E*. All the programming functions will now be stored in permanent memory and will be protected by the security code from accidental or unauthorised adjustment.

8. MAINTENANCE

8.1 Fault finding during commissioning

If a BA334ND fails to function during commissioning the following procedure should be followed:

Symptom	Cause	Check:
No display	Incorrect wiring Note: Terminals 2, 4, 6 & 8 are interconnected within the BA334ND	That there is between 10 and 30V on terminals 1 & 2 with terminal 1 positive.
Flow indicator not rotating	No input pulses, incorrect input terminals used, or incorrect type of input selected	That BA334ND has been calibrated for the correct input. That input signal is connected to correct input terminals and correctly polarised.
Flow indicator rotating but incorrect rate display	Incorrect calibration Input below clip-off threshold	That rate scale factor and timebase are correctly programmed. That clip-off threshold is set correctly.
Unstable rate display	Noisy pulse input signal	Source of noise and try to eliminate or increase rate filter.
Correct rate display but incorrect total display	Incorrect calibration Remote reset switch contacts closed	That total scale factor is correctly programmed. That 'RESET' annunciator is not activated. If it is, check reset wiring and switch.
Unable to enter programme mode	Incorrect security code	That the correct security code is being used, or fit security link in override position. See Fig 7.
Clip-off does not function and 4/20mA output is constantly 3.5mA	Clip-off & 4/20mA have been automatically reset to zero following change of rate display calibration	Re-enter required clip-off and 4/20mA output calibration.
Alarms do not function	Alarms have been disabled following calibration change	Re-enable both alarms.

8.2 Fault finding after commissioning

ENSURE PLANT SAFETY BEFORE STARTING MAINTENANCE

Live maintenance should only be performed when there is no risk of a flammable atmosphere being present and dust and water can not enter the enclosure. Before replacing control and terminal covers ensure that the sealing gaskets are undamaged and are free from foreign bodies.

If a BA334ND fails after it has been functioning correctly, the following table may help to identify the cause of the failure.

Symptom	Cause	Check:
No display	No power supply.	That there is between 10 and 30V on terminals 1 & 2.
Flow indicator not rotating	No input pulses	Output from flowmeter. Wiring between flowmeter and BA334ND.
Flow indicator rotating, but rate display indicates zero and there is no totalisation	Input below clip-off threshold	Clip-off threshold and if necessary adjust.
Unstable rate display	Noisy pulse input signal	Source of noise and try to eliminate, or increase rate filter.

If this procedure does not reveal the cause of the fault, it is recommended that the instrument is replaced.

8.3 Servicing

We recommend that faulty BA334ND rate totalisers are returned to BEKA associates or to our local agent for repair.

8.4 Routine maintenance

The mechanical and electrical condition of the instrument should be regularly checked. Initially annual inspections are recommended, but the inspection frequency should be adjusted to suit the environmental conditions.

8.5 Guarantee

Instruments which fail within the guarantee period should be returned to BEKA associates or our local agent. It is helpful if a brief description of the fault symptoms is provided.

8.6 Customer comments

BEKA associates is always pleased to receive comments from customers about our products and services. All communications are acknowledged and whenever possible, suggestions are implemented.

9. ACCESSORIES

9.1 Units of measurement and instrument identification

All BA334ND rate totalisers are fitted with a display label behind the armoured glass window. This label can be supplied printed with any units of measurement and tag information specified when the instrument is ordered. Alternatively the information may be added on-site via an embossed strip, dry transfer or a permanent marker.

To gain access to the display label remove the terminal cover by unscrewing the two 'A' screws which will reveal two concealed 'D' screws. Remove all four 'D' screws and carefully lift off the front of the instrument - see Fig 3. Add the required legend to the display label, or replace with a new pre-printed label which is available from BEKA associates.

The BA334ND can also be supplied with a blank or custom engraved stainless steel plate secured by two screws to the side of the instrument enclosure. This plate can accommodate:

1 row of 9 alphanumeric characters 10mm high

or 1 row of 11 alphanumeric characters 7mm high

or 2 rows of 18 alphanumeric characters 5mm high

9.2 Alarms

The BA334ND can be supplied with two solid state single pole outputs which may be independently programmed as high or low, rate or total alarms with normally open or normally closed outputs.

WARNING

These alarm outputs should not be used for critical safety applications such as a shut down system.

When the BA334ND power supply is turned off or disconnected, both BA334ND alarm outputs will open irrespective of whether normally open or normally closed outputs have been selected. When designing a system an open output should therefore be the alarm condition.

Alarm annunciators on the instrument display indicate the status of both alarms. If an alarm delay or silence time has been selected the annunciator will flash during the delay or silence period.

Programmable functions for each alarm include adjustable setpoint, alarm delay time and alarm accept time. Hysteresis may be applied to rate alarms.

The BA334ND total display is up-dated and compared with the programmed alarm setpoint twice per second, irrespective of the display update time selected. This may result in the total alarm being delayed for up to half a second after the total has exceeded the setpoint.

9.2.1 Solid state output

Each alarm has a galvanically isolated single pole solid state switch output as shown in Fig 8. The outputs are polarised and current will only flow in one direction. Terminals A1 and A3 should be connected to the positive side of the supply.

$$\begin{aligned} R_{on} &= 5\Omega + 0.6V \\ R_{off} &= \text{greater than } 180k \end{aligned}$$

Note: Because of the series protection diode some test meters may not detect a closed alarm output

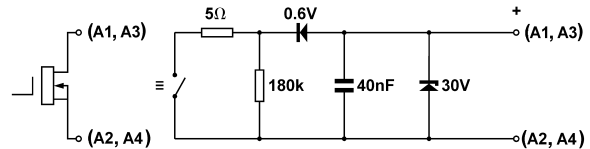

Fig 8 Equivalent circuit of each alarm output

9.2.2 Type nL certification

Each of the two alarm outputs is a separate galvanically isolated solid state switch which has been certified as a separate Ex nL circuit. The maximum input safety parameters for each alarm are:

$$\begin{aligned} U_i &= 30V \text{ dc} \\ I_i &= 100mA \text{ dc} \end{aligned}$$

This allows each alarm output to switch any dc circuit providing that in normal operation the maximum supply voltage is not greater than 30V dc and the maximum current is not greater than 100mA dc.

Fig 9 shows a typical application in which alarm one has been programmed as a total alarm to control a pump. The second alarm has been programmed as a rate alarm to control a solenoid valve.

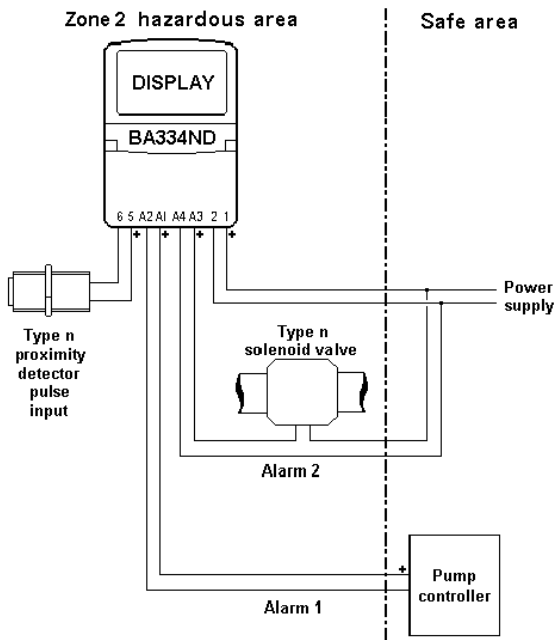

Fig 9 Typical alarm application

9.2.3 Programming and adjustment

When a BA334ND is supplied with alarms the main programme menu is extended as shown in Fig 10. The two alarm functions appear between the 'LOC-rSEt' and the 'CLr.GtOt' functions, and each alarm may be programmed as a rate or a total alarm.

For simplicity Fig 10 only shows the programmable functions on the rate option of alarm AL1. Alarm 2 and the total options are identical except that the total alarms do not have hysteresis.

The following table summarises each of the alarm programme functions and includes a cross reference to more detailed information. Again only the functions on alarm AL1 are listed.

Summary of programmable alarm functions

<u>Display</u>	<u>Description of function</u>
'EnbL'	Alarm enable Enables or disables the alarm function without changing the alarm parameters. See section 9.2.4
'tYPE'	Type of alarm Defines whether the alarm operates on the rate or total display. See section 9.2.5
'SPr1' 'SPt1'	Alarm setpoint 1 Adjusts the alarm setpoint; alarm is activated when the rate or total display equals the setpoint. Note: 'SPr1' is displayed for a rate alarm and 'SPt1' for a total alarm. See section 9.2.6
'HI.LO'	Alarm function Defines whether the alarm has a high or low function See section 9.2.7
'no.nc'	Normally open or normally closed output Determines whether the single pole alarm output is open or closed in the non-alarm condition. See section 9.2.8
'HStr'	Hysteresis Adjusts the alarm hysteresis. Only available on rate alarms. See section 9.2.9
'dELA'	Alarm delay time Adjusts the delay between the display equalling the setpoint and the alarm output being activated. See section 9.2.10
'SIL'	Alarm silence time Defines the time that the alarm output remains in the non-alarm condition following acceptance of an alarm. See section 9.2.11
'AcSP'	Access setpoint Sub-menu that enables direct access to the alarm setpoints from the display mode and defines a separate security code. See section 9.2.12

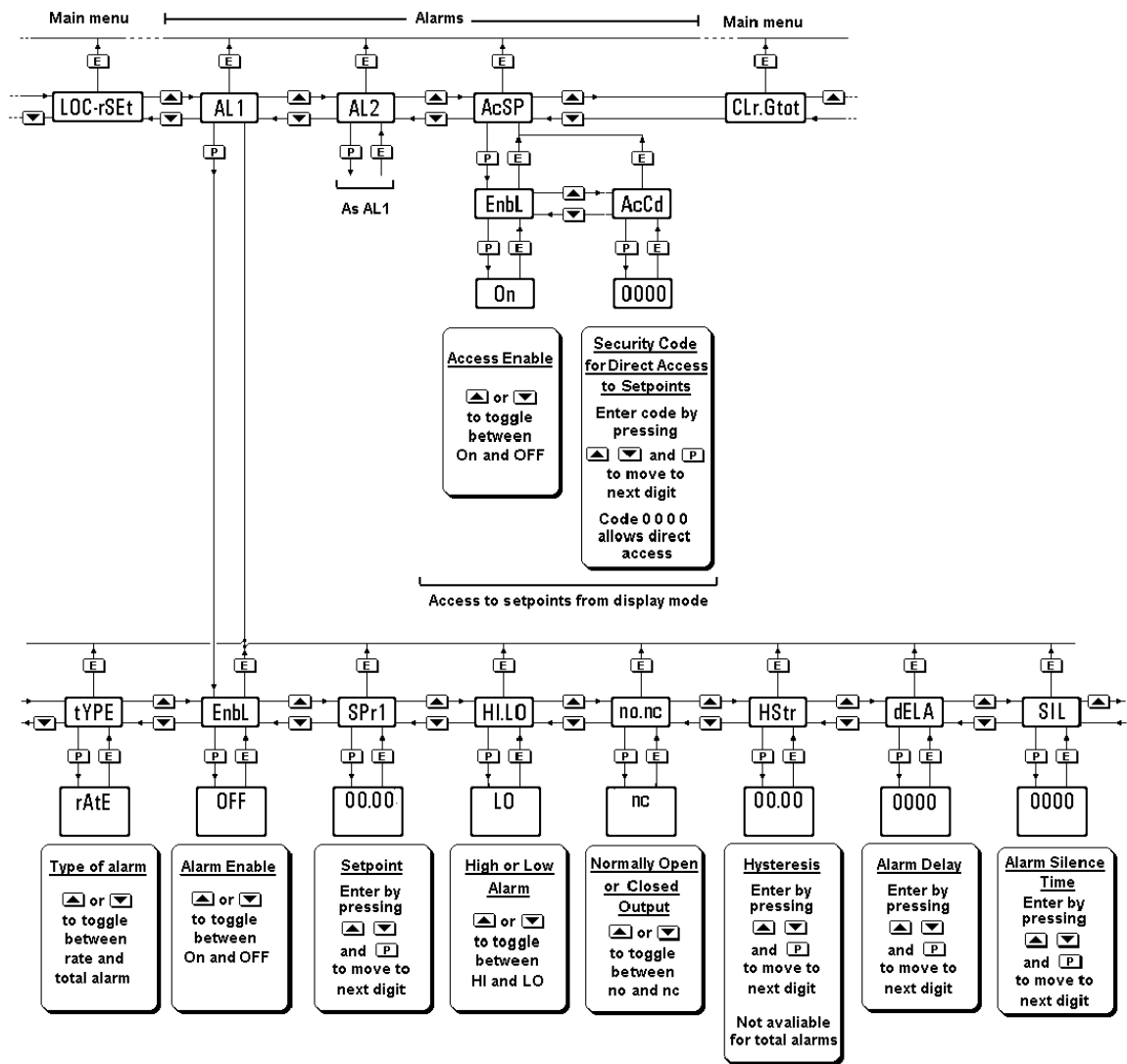

Fig 10 Alarm programme menu

9.2.4 Alarm enable: 'EnbL'

This function allows the alarm to be enabled or disabled without altering any of the alarm parameters. To check or change the function select 'EnbL' from the alarm menu and press *P* which will reveal the current setting. The function can be changed by pressing the *Up* or *Down* button followed by the *E* button to return to the alarm menu.

Note: The alarms will be automatically disabled after the rate or total displays have been recalibrated, or the alarm type has been changed. Both alarms must therefore be enabled after calibration changes.

9.2.5 Type of alarm: 'tYPE'

Alarm 1 and Alarm 2 may both be rate or total alarms, or one may be conditioned for rate and the other for total.

To check or change the type of alarm, select 'tYPE' from the alarm menu and press *P* which will reveal the current setting. The function can be changed by pressing the *Up* or *Down* button followed by the *E* button to return to the alarm menu.

Note: When 'tYPE' is changed, the alarm parameters are automatically set to the default values and the alarm is disabled. It must therefore be reprogrammed before use.

9.2.6 Setpoint adjustment: 'SPx1' and 'SPx2'

The rate alarm setpoints SPr1 and SPr2 may be positioned anywhere between 0 and 999999, and the total alarm setpoints SPT1 and SPT2 anywhere between 00000000 and 99999999.

To adjust the setpoint of alarm 1 select 'SPr1' or 'SPT1', depending upon how it has been programmed, from the alarm menu. Press *P* which will reveal the existing value with one digit flashing. Each digit of the setpoint can be adjusted using the *Up* and *Down* push-buttons, and the *P* button to move to the next digit. The position of the decimal point is defined by the d.P. function which should be set first. When the required value has been entered press *E* to return to the alarm menu.

Note: 'SPr1' is displayed when alarm 1 has been programmed as a rate alarm and 'SPT1' when programmed as a total alarm.

9.2.7 Alarm function: 'HI.LO'

Each alarm must be conditioned as a high or low alarm. To check or change the alarm function select 'HI.LO' from the alarm menu

and press *P* to reveal the current setting. The function can be changed by pressing the *Up* or *Down* buttons followed by the *E* button to return to the alarm menu.

9.2.8 Alarm output status: 'no.nc'

The two alarm outputs may be open or closed in the non-alarm condition. When the BA334ND power supply is turned off or disconnected, both the alarm outputs will open irrespective of whether normally open or normally closed outputs have been selected. Therefore, when designing an alarm system normally closed 'nc' should be selected so that the output opens when an alarm occurs or if the power supply fails.

To check the alarm output status select 'no.nc' from the alarm menu and press *P* to reveal the current setting. The function can be changed by pressing the *Up* or *Down* button followed by the *E* button to return to the alarm menu.

9.2.9 Hysteresis: 'HStr'

Hysteresis is only available on rate alarms. During programming hysteresis is shown in the units of rate the BA334ND has been calibrated to display.

To adjust the hysteresis, select 'HStr' from the alarm menu and press *P* which will reveal the existing figure. Each digit can be adjusted using the *Up* and *Down* push-buttons, and the *P* button to move to the next digit. When the required hysteresis has been entered, press *E* to return to the alarm menu.

e.g. A BA334ND calibrated to display a flow of 0 to 5000, with a high alarm set at 4000 and hysteresis of 100 will perform as follows:

High alarm will be activated when flow equals or exceeds 4000, but will not reset until the flow falls below 3900.

9.2.10 Alarm delay: 'dELA'

This function enables activation of the alarm output to be delayed for a fixed time following the alarm condition occurring. The delay can be programmed in 1 second increments up to 3600 seconds. If a delay is not required zero should be entered. To adjust the delay select 'dELA' from the alarm menu and press *P* which will reveal the existing delay time. Each digit of the delay can be adjusted using the *Up* and *Down* push-buttons, and the *P* button to move to the next digit. When the required delay has been entered, press *E* to return to the alarm menu.

The alarm annunciator will start flashing immediately an alarm occurs and continue for the delay time after which the alarm output will be activated.

9.2.11 Alarm silence time: 'SIL'

The alarm silence function is primarily intended for use in small installations where the alarm output directly operates an annunciator such as a sounder. When the alarm silence time is set to any figure other than zero, the *P* push-button becomes an alarm accept button.

After an alarm has occurred, operating the *P* button will cause the alarm output to revert to the non-alarm condition for the programmed alarm silence time. When an alarm is silenced the alarm annunciator will flash until the silence time expires.

To adjust the silence time select 'SIL' from the alarm menu and press *P* which will reveal the existing time. The time may be adjusted to between 0 and 3600 seconds in 1 second increments. Each digit can be adjusted using the *Up* and *Down* push-buttons, and the *P* button transfers control to the next digit. When the required time has been entered press *E* to return to the alarm menu.

9.2.12 Access Setpoint: 'AcSP'

This function activates a separate menu that provides direct access to the alarm setpoints when the instrument is in the display mode. See section 9.2.13 for a full description. An operator may therefore adjust the alarm setpoints without having access to the programme and alarm menus. Further protection is provided by a separate security code.

This direct access menu may be enabled and a separate security code entered from the 'AcSP' function in the main programme menu as shown in Fig 10. To change the menu parameters select 'AcSP' from the programme menu and press *P*. This will display the enable prompt 'EnbL'.

Press *P* again to reveal if the direct access menu is 'On' or 'OFF'. The *Up* or *Down* buttons will toggle the display between the two conditions.

If 'OFF' is selected, the operator will not have access to the setpoints from the display mode. Return to the 'AcSP' prompt in the main menu by pressing *E* twice.

If 'On' is selected, the operator will have direct access to the alarm setpoints from the display

mode via a separate optional security code. To define this four digit numeric code press *E* to return to the 'EnbL' prompt followed by the *Up* or *Down* button to select the access code prompt 'AcCd'. Pressing *P* will then reveal the current security code. The flashing digit of the code may be changed by operating the *Up* or *Down* push-buttons and pressing the *P* button will transfer control to the next digit. When the required code has been entered, press *E* twice to return to the 'AcSP' prompt in the programme menu.

Entering code 0000 will disable the security code allowing direct access to the setpoints in the display mode by pressing the *P* and *Up* buttons simultaneously.

New instruments with alarms are supplied with the security code set to 0000

9.2.13 Adjusting alarm setpoints from the display mode

Access to the two alarm setpoints from the rate totaliser display mode is obtained by operating the *P* and *Up* push-buttons simultaneously as shown in Fig 11

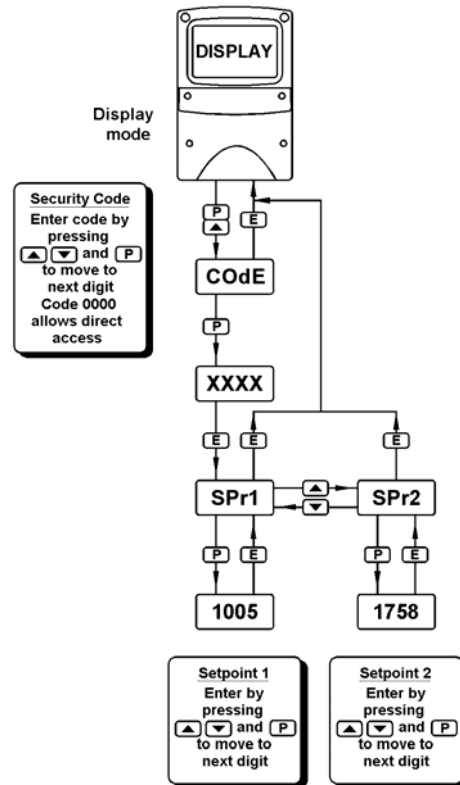

Fig 11 Setpoint adjustment from the display mode

If the setpoints are not protected by a security code the alarm setpoint prompt 'SPr1' or 'SPt1' will be displayed depending upon whether a

rate or total alarm has been programmed. If the setpoints are protected by a security code, 'COde' will be displayed first. Pressing *P* again will enable the alarm security code to be entered digit by digit using the *Up* and *Down* buttons to change the flashing digit and the *P* push-button to move control to the next digit. If the correct code is entered pressing *E* will then cause alarm setpoint prompt 'SPx1' to be displayed. If an incorrect security code is entered, or a button is not pressed within ten seconds, the instrument will automatically return to the display mode.

Once within the menu pressing the *Up* or *Down* buttons will toggle the display between the two alarm setpoint prompts 'SPx1' and 'SPx2'.

To adjust an alarm setpoint select 'SPx1' or 'SPx2' and press *P* which will reveal the current setting. Each digit of the setpoint may be adjusted using the *Up* and *Down* push-buttons, and the *P* button to move control to the next digit. When the required setpoint has been entered, pressing *E* will return the display to the 'SPx1' or 'SPx2' prompt from which the other setpoint may be selected, or the indicator may be returned to the display mode by pressing *E* again.

Note: Direct access to the alarm setpoints is only available when the menu is enabled - see section 9.2.12

9.3 Display backlight

The BA334ND can be supplied with LED backlighting to improve display contrast when the instrument is installed in a poorly illuminated area. The backlight is electrically segregated from the measuring circuit and has been certified as a separate Ex nL Group II Category 3G circuit.

The Type nL input parameters are:

$$\begin{aligned} U_i &= 30\text{V dc} \\ I_i &= 100\text{mA dc} \end{aligned}$$

This allows the backlight to be powered from any safe area 18 to 30V dc supply providing that in normal operation the maximum supply voltage is not greater than 30V dc and the maximum current is not greater than 100mA dc. See Fig 12.

Reducing the supply voltage below 18V or fitting a current limiting resistor in series with the supply will reduce the display brilliance.

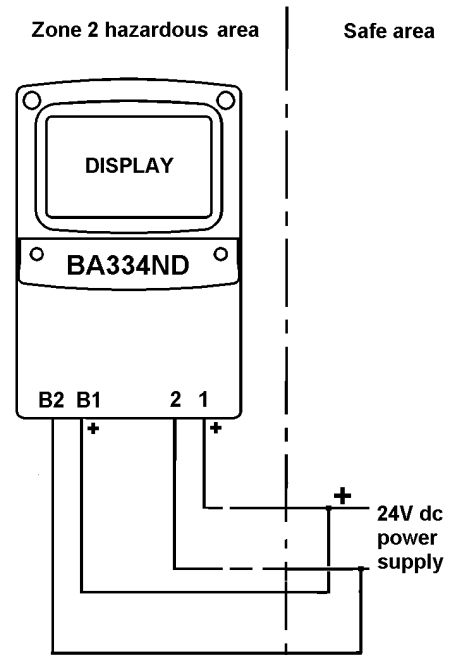

Fig 12 Backlight powered from instrument supply

9.4 Pulse output

The BA334ND may be supplied with an opto-isolated solid state pulse output. This output is a polarised current sink that closes for a programmable duration each time the least significant digit of the BA334ND display changes. A programmable divider enables the pulse output frequency to be reduced by 10, 100, 1,000 or 10,000. See Fig 14.

$$\begin{aligned} R_{on} &= 60\Omega + 3V \\ R_{off} &= 1M \end{aligned}$$

The output pulse is not synchronous with the input pulse and the maximum pulse frequency is determined by the programmed pulse width.

$$\text{Max frequency} = \frac{1}{2 \times (\text{pulse duration})} \text{ Hz}$$

If the instrument power supply fails or is disconnected, any untransmitted output pulses will be lost.

To comply with the Ex nL certification, the maximum pulse supply voltage and current must not exceed 30V dc and 100mA dc in normal operation.

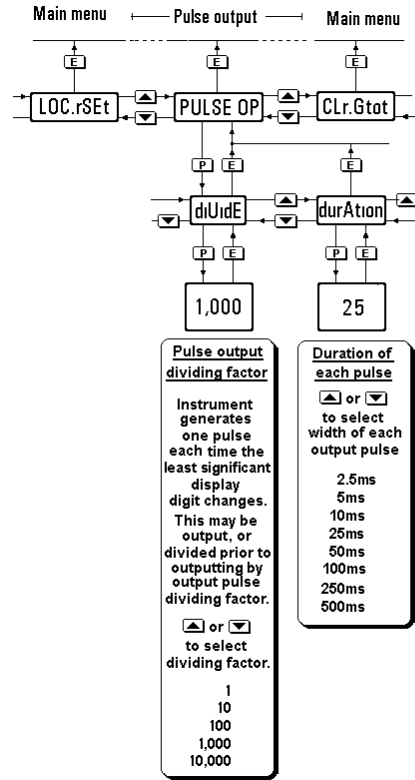

Fig 14 Pulse output menu

Zone 2 hazardous area | **Safe area**

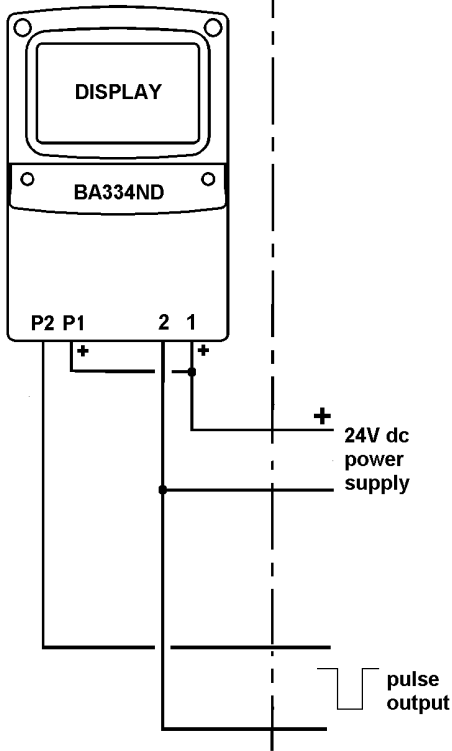

Fig 13 Application of pulse output

9.5 4/20mA output

The BA334ND can be supplied with an isolated 4/20mA current sink which may be programmed to produce an analogue output proportional to the whole or part of the rate display.

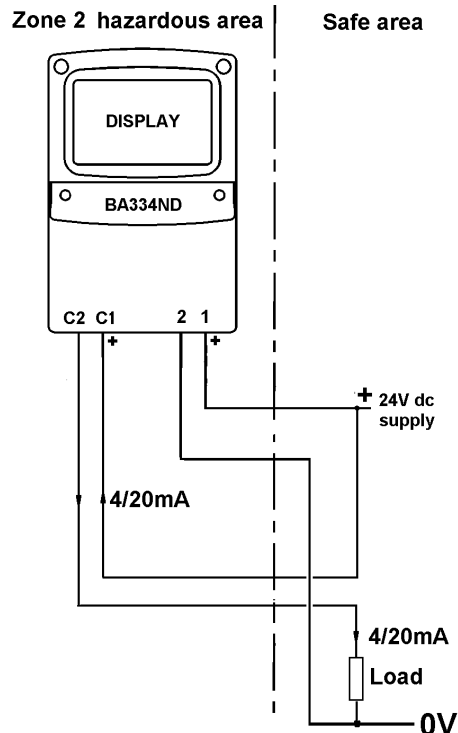

Fig 15 Application of 4/20mA output

To comply with the Ex nL certification requirements, in normal operation the maximum supply voltage and current connected to the 4/20mA current sink must not exceed 30V dc and 100mA dc.

9.5.1 Programming and adjustment

The main programme menu is extended as shown in Fig 16 to accommodate the 4/20mA calibration functions.

The '4-20 OP' programme function allows the 4/20mA output current to correspond to any rate display. e.g. 4mA could represent 10 litres/minute and 20mA 100 litres/minute.

To calibrate the 4/20mA output current, enter the programme mode by operating the *P* and *E* push-buttons simultaneously. If the instrument is not protected by a security code the first parameter 'UPdAtE' will be displayed. Enter the security code if the instrument is protected.

Using the *Up* or *Down* push button select the function '4-20 OP' and press *P* which will result in the BA334ND displaying '4.000' which is the prompt for setting the rate display corresponding to an output current of 4.000mA. Pressing *P* will reveal the existing setting with the most significant digit flashing. The decimal point will be fixed in the position already defined for the rate display by the 'd.P' function. The value of the flashing digit may be changed by pressing the *Up* or *Down* buttons. When this digit is set as required, pressing *P* will transfer control to the next digit.

When the flow rate corresponding to an output current of 4mA has been entered, press the *E* button to return to the '4.000' prompt.

To enter the rate display corresponding to an output current of 20.000mA, press the *Up* or *Down* button to select the '20.000' prompt followed by *P* to reveal the current setting. This may be changed in the same way as the 4mA setting. When set as required, press *E* three times to return to the display mode via the '20.000' and '4-20 OP' prompts.

The 4/20mA output may be calibrated to increase or decrease as the rate display increases, and most instruments will produce a linear output between 3.5 and 22mA.

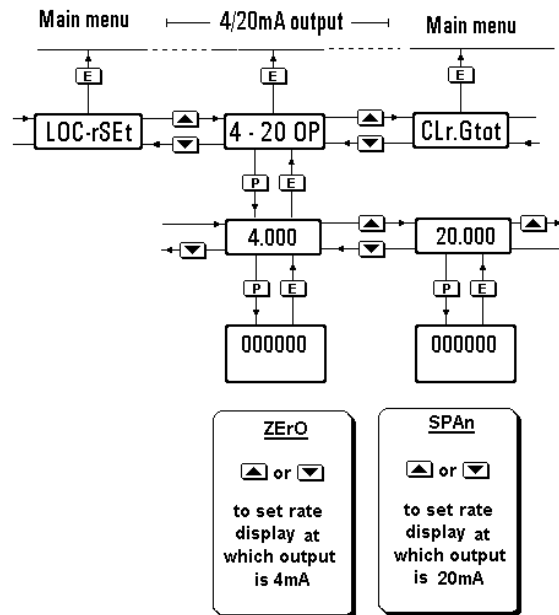

Fig 16 4/20mA output programme structure

Note: If the rate display calibration is changed by adjusting the rate scale factor SCALE-r, the timebase t-bASE, or the position of the rate display decimal point, the 4/20mA output will automatically be set to give a constant 3.5mA output irrespective of the rate display. The 4/20mA output must therefore always be recalibrated following recalibration of the rate display.

Note 2: If the BA334ND and the 4/20mA current sink output are powered from separate supplies, the 4/20mA output current will continue to flow when the BA334ND supply fails or is turned off. Powering both from a common supply as shown in Fig 15 eliminates this effect.

9.6 External push-buttons

For applications requiring frequent access to the programme menus the BA334ND can be supplied with an external membrane keypad. These switches, which maintain the IP66 integrity of the enclosure, allow all functions to be controlled without removing either of the enclosure covers.

9.7 Pipe mounting kits

Two pipe mounting kits are available for securing the BA334ND to a horizontal or vertical pipe.

BA392D Stainless steel bracket secured by two worm drive hose clips for 60 to 80mm outside diameter pipes.

BA393 Heavy duty stainless steel bracket secured by a single 'V' bolt. Will clamp to any pipe with an outside diameter between 40 and 80mm.

9.8 Stem mounting kit

The BA395 stem mounting kit comprises a short length of stainless steel conduit with a male M20 x 1.5 thread at both ends. This enables the BA334ND to be mounted directly onto a flow transmitter conduit entry.

10. INDEX

Subject	Section	Subject	Section
'AcSP'	9.2.3; 9.2.12	'LOC.rSEt'	6.12
Alarms optional	9.2	Local reset	6.13
access	9.2.3; 9.2.12	Location	5.1
output	9.2.3; 9.2.8		
delay time	9.2.3; 9.2.10	Maintenance	8.0
enable	9.2.3; 9.2.4	routine	8.4
function	9.2.3; 9.2.7	Mounting kits	
hysteresis	9.2.3; 9.2.9	pipe	9.7
programming	9.2.3	stem	9.8
setpoint	9.2.3; 9.2.6		
silence time	9.2.3; 9.2.11	'no.nc'	9.2.3; 9.2.8
solid state output	9.2.1		
type	9.2.3; 9.2.5	Push-buttons	
ATEX Directive	3.2; 3.7	<i>Down</i>	2.2
		<i>E</i>	2.2
		<i>P</i>	2.2; 9.2.11
		<i>Up</i>	2.2
		External optional	9.6
		Pulse output optional	9.4
Backlight optional	9.3		
Calibration		Rate	
structure	6.1; Fig 6	display	2.2
programme access	6.2	scale factor	6.8
example	7	filter	6.10
Certificates		Reset	
conformity	3.1	local	6.13
ATEX	3.2	remote	3.5; 4.4
'CLIP-OFF'	6.12		
Clipoff	6.12	'SCALE-r'	6.8
'CodE'	6.15	'SCALE-t'	6.11
		Security code	6.15
Decimal points	6.6	Servicing	8.3
'dELA'	9.2.3; 9.2.10	'SIL'	9.2.3; 9.2.11
Display	2.3	'SPxx'	9.2.3; 9.2.6
exchange rate & total	6.6		
lower – turn off	6.7	't-bASE'	6.9
update interval	6.4	T rating	3.6
'dISPLAY.2'	6.7	Terminal numbers	Fig 4
'd.P.'	6.6	Timebase	6.9
		Total	
'EnbL'	9.2.3; 9.2.4	display	2.3
		scale factor	6.11
Fault finding		'tYPE'	9.2.3; 9.2.5
during commissioning	8.1	Type nL certification	3; 3.1; 9.2.2; 9.5
after commissioning	8.2	Type of input	6.5
'FILtEr'	6.10		
Flow indicator	2.3	Units of measurement	9.1
		'UpdAtE'	6.4
Gas groups	3.6		
Grand total	2.2	Zones	3.6
clear	6.14		
Guarantee	8.5	4/20mA output optional	9.5
'HI.LO'	9.2.3; 9.2.7		
'HStr'	9.2.3; 9.2.9		
'InPut'	6.5		
Installation	5		
Instrument identification	9.1		