

Standard display formats:  
1, 2, 3, 4 or 8 variables  
some with bargraphs.

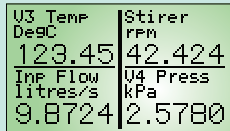

Some of the standard screens

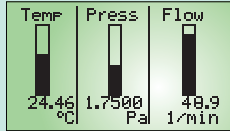
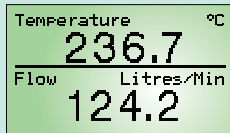
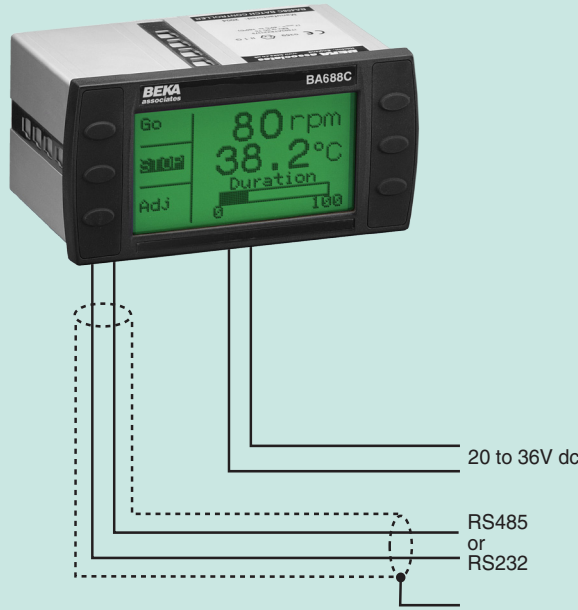

The **BA688C** is a dc powered instrument that can display text and simple graphics in a process area. Incorporating six push buttons and two single pole outputs, the BA688C is a robust low cost operator interface ideal for simple machine and process control applications.

Available with either an **RS485** or **RS232** port and incorporating Modbus RTU, BEKA and Legacy protocol, the BA688C may be directly connected to many industrial networks and instruments, including new installations and upgrades to existing systems.

A **high contrast liquid crystal display** incorporates a green backlight allowing the display to be read in all lighting conditions from full sunlight to total darkness. The text display is therefore suitable for mounting in control panels or incorporated into measuring instruments.

**Six push buttons** which may be used for operator acknowledgments or controls are included on the instrument front panel. If larger industrial switches are required, these may be connected to the text display rear terminals. When activated, the front panel push buttons are automatically disabled.

**Two single pole switch outputs**, which are controlled via the serial data link, may be used to switch a small load such as a valve, actuator or sounder.

**Standard screen formats** contain one, two, three, four or eight variables, together with units of measurement, tag descriptions and bargraphs on some of the screens. Use of one of these eleven standard screens greatly reduces the amount of programming required and will satisfy most display requirements. If a custom display format is required, this can be developed using BEKA protocol.

The **BA688C** is a **Modbus RTU slave** that can display up to eight process variables together with units of measurement and tag descriptions. When used with one of the eleven standard screen formats, no programming is required apart from setting the BA688C communication parameters and writing each Modbus variable into the BA688C

Modbus register address map. If a custom screen layout is required in a Modbus system this can be constructed using the BEKA protocol.

**BEKA protocol** enables custom screen formats to be designed and stored in non-volatile memory using a wide selection of lines, boxes, bargraphs and fonts. Although screens can be manually designed, free BEKA ScreenWriter software which will run on a PC simplifies the process.

**Legacy protocol** enables the BA688C to replace an MTL644 for safe area applications without the need for a galvanic communications isolator and with the added advantage of a display backlight. No software changes are required and the BA688C will fit into the existing panel cut-out. If required, simple modifications to the host software will allow the enhanced features of the BA688C to be used i.e. five font sizes, simple graphics, additional operator buttons and a second output.

**Scripts** are a sequence of commands, downloaded to and stored in non-volatile memory by the BA688C text display, that can be executed by the instrument without intervention from the host. For example a routine may be written to monitor the instruments push-buttons and to change the displayed screen or variable depending upon which button has been operated.

**Pattern matching** is a powerful feature which allows the BA688C to capture and display data contained in a proprietary ASCII serial string, such as that from a weighing system or barcode reader primarily intended for printing.

The **front panel** of the BA688C has IP66 protection and a neoprene gasket seals the joint between the text display and the panel, making it suitable for use in areas that will be hosed.

To **simplify system design** the instruction manual is supplemented by comprehensive Modbus and programming guides plus a free instrument simulator which will run on a PC. All are available from the BEKA sales office or may be downloaded from [www.beka.co.uk](http://www.beka.co.uk)

# BA688C

## Serial text display

### General purpose

- ◆ High contrast display with backlight.
- ◆ Modbus RTU slave
- ◆ BEKA and Legacy protocols.
- ◆ 11 standard screen formats.
- ◆ Six operator push-buttons & two switch outputs.
- ◆ IP66 front panel
- ◆ Free simulator and ScreenWriter software.
- ◆ 3 year guarantee

[www.beka.co.uk/ba688c](http://www.beka.co.uk/ba688c)



BEKA associates Ltd. Old Charlton Rd.  
Hitchin, Hertfordshire, SG5 2DA, U.K.  
Tel. (01462) 438301 Fax (01462) 453971  
e-mail [sales@beka.co.uk](mailto:sales@beka.co.uk) [www.beka.co.uk](http://www.beka.co.uk)

## SPECIFICATION

### Power supply

Voltage	20 to 36V dc
Current	95mA max

### Display

Type	120 x 64 pixel backlit liquid crystal
Size	86.5 x 45mm
Screens	11 standard formats
	1, 2, 3, 4 or 8 variables plus units of measurement & tag information, some include bargraphs.
Custom format	See Programming Guide
	ASCII character set, 5 font sizes.
Hidden screen	May be written to at any time and displayed when required.

### Controls

Front panel	Six push-buttons which can be software interrogated. Each button function may be displayed on the screen. Buttons may be disabled.
External switches	Control may be transferred to six external switches; front panel buttons are inhibited.
Switch cable length	5m max

### Outputs

Rating	Two software controlled single pole relay contacts. 250V; 5A ac 30V; 5A dc Reactive loads must be suppressed
--------	---

### Data transmission

Speed	0.3, 0.6, 1.2, 2.4, 4.8, 9.6, 19.2, 38.4, 67.6 & 115.2k bps.
Format	1 or 2 stop bits; odd, even or no parity bit; 7 or 8 data bits.
Protocol	Selectable Modbus RTU, BEKA or Legacy that is compatible with the MTL643 & MTL644.

Address	
Modbus protocol	1 – 247
BEKA protocol	0 – 247
Legacy protocol	0 – 15

Zero reserved for single instrument applications.

### Environmental

Operating temp	-20 to 60°C
Storage temp	-40 to 85°C
Humidity	To 95% @ 40°C
Enclosure	Front IP66, rear IP20
EMC	Complies with EMC Directive 2014/30/EU.
Immunity	No error for 10V/m field strength between 150kHz and 1GHz.
Emissions	Complies with the requirements for Class B equipment.

### Mechanical

Terminals	Removable with screw clamp for 0.5 to 1.5mm <sup>2</sup> cable.
Weight	0.7kg

### Accessories

Tag number	Thermally printed strip on rear of instrument.
Modbus Guide	May be downloaded from <a href="http://www.beka.co.uk">www.beka.co.uk</a>
Programming Guide	
Instrument simulator	
BEKA ScreenWriter	Custom screen design aid for personal computer.

## DIMENSIONS (mm)



### Recommended panel cut-out

To achieve an IP66 seal between the instrument and the panel  
136.0 +0.5/-0.0 x 66.2 +0.5/-0.0  
Four panel mounting clips must be used

DIN 43 700

138.0 +1.0/-0.0 x 68.0 +0.7/-0.0

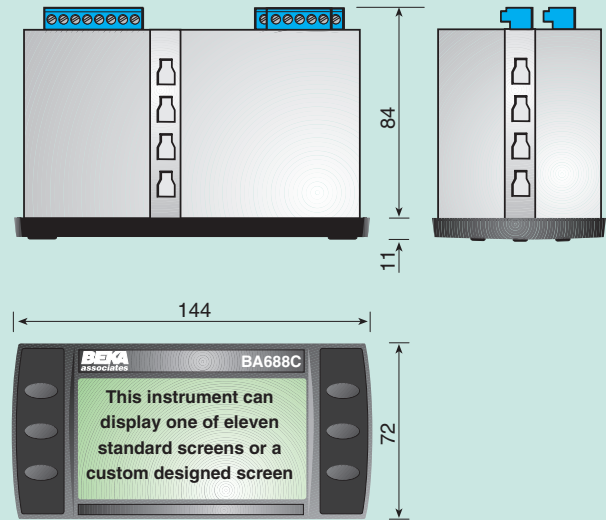

## TERMINAL CONNECTIONS

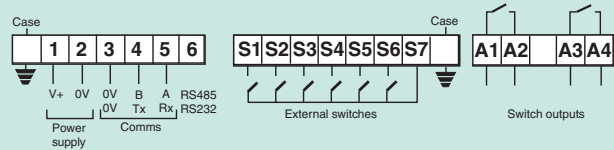

## CONNECTION

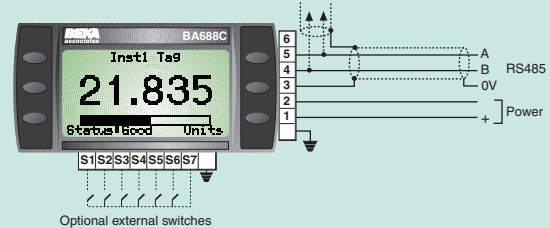

### Connections for RS485 communication

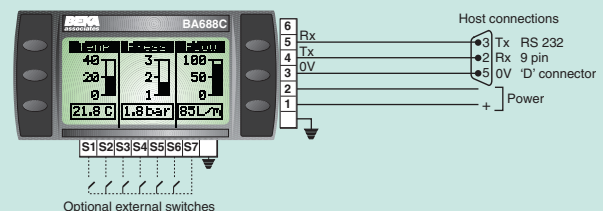

### Connections for RS232 communication

## HOW TO ORDER

### Please specify

Model number  
Communication port  
**Accessories**  
Tag number  
Modbus Guide  
Programming Guide  
Instrument simulator

BA688C

RS485 or RS232

### Please specify if required

Legend  
Serial Text Display – Modbus Guide  
Serial Text Display – Programming Guide  
Instrument simulator for use on personal computer.