

The **BA577E** is a general purpose instrument with one input that may be configured as a Timer or as a Clock. As a Timer it is able to measure and display the elapsed time between external events, or control external events via two optional control outputs. When configured as a Clock the instrument can display time in a variety of formats. The BA577E is controlled by a single input which may be configured on-site to operate with a magnetic pick-off, switch contact, proximity detector, open collector or a voltage output sensor.

**Configuration** may be performed on-site via the front panel push buttons using easy to use and well documented menus. The Timer employs a state and event structure to simplify configuration. The BA577E can be supplied configured to customers requirements including a customer defined printed slide-in scale card for no additional charge.

**Applications as a Timer** include displaying the time interval between two events detected by a process area sensor such as a 2-wire proximity detector connected to the single input. With the addition of optional dual control outputs, the Timer can perform control functions such as repetitively opening a solenoid valve for a defined time. The Timer includes a powerful cycle function which can be configured to repeat a timing function up to 99 times or continuously, with up to 100 hours delay between timed periods.

**As a Clock** local time can be displayed in various twelve or twenty four hour formats and the display may be synchronised to a pre-set time via the external reset input. Optional control outputs may be configured to switch loads on or off at pre-set times twice during each twenty four hour period.

The **display** has high contrast and a wide viewing angle enabling the instrument to be read in most lighting conditions over a wide temperature range.

**Display backlighting** which is internally powered, is available as a factory fitted option. It provides green background illumination enhancing daylight viewing and allowing the display to be easily read at night or when installed in a poorly illuminated area.

**IP66 front panel protection** with a neoprene gasket to seal the joint between the instrument and the instrument panel, allows the BA577E to be installed in areas that will be washed down.

**Optional control outputs** can switch loads such as a sounder or solenoid valve. The two galvanically isolated, solid state voltage free outputs may be independently conditioned with normally open or closed outputs. Annunciators on the BA577E display show the status of both control outputs.

**If a larger display is required** the BA578E is a two input Timer or Clock housed in a Noryl 144 x 72mm DIN enclosure. For installations in marine or hostile environments the BA577E-SS is functionally identical to the BA577E but is housed in an impact resistant rugged stainless steel enclosure with a 10mm thick toughened glass window.

**For applications in flammable atmospheres** the BA377E, which is identical to the BA577E, has international intrinsic safety certification. For applications in Zone 2 or 22 the rugged stainless steel BA377NE has Ex nA and Ex tc certification allowing installation without Zener barriers or galvanic isolators.

# BA577E

## One input timer or clock

### General purpose

- ◆ May be configured as a Timer or as a Clock.
- ◆ Configurable input: magnetic pick-off, switch contact, proximity detector, open collector or voltage pulse.
- ◆ Two separate displays
- ◆ 96 x 48mm DIN enclosure with IP66 front protection.
- ◆ Simple on-site scale card installation.
- ◆ Optional: Backlight  
Dual control outputs
- ◆ 3 year guarantee

[www.beka.co.uk/ba577e](http://www.beka.co.uk/ba577e)

# BEKA

## associates

BEKA associates Ltd. Old Charlton Rd.  
Hitchin, Hertfordshire, SG5 2DA, U.K.  
Tel. (01462) 438301 Fax (01462) 453971  
e-mail [sales@beka.co.uk](mailto:sales@beka.co.uk) [www.beka.co.uk](http://www.beka.co.uk)

## SPECIFICATION

### Power supply

Voltage	10 to 30V dc		
Current	16mA max plus 22.5mA for optional backlight.		

### Input

	Lower	Upper	switching thresholds
Switch contact	100Ω	1kΩ	
Proximity detector (NAMUR)	1.2mA	2.1mA	
Open collector	2kΩ	10kΩ	
Magnetic pick-off	0	+40mV	
Voltage pulse (low)	1V	3V	30V max
Voltage pulse (high)	3V	10V	30V max

### Display

Type	Liquid crystal
Primary	9mm high
Secondary	6mm high
Format	hh:mm:ss ; hh:mm ; mm:ss or s

### Remote Timer reset & Clock sync.

Contact closure with resistance less than 10kΩ

### Timer

Maximum duration	99h 59m and 59s or equivalent in any display format.
Maximum delay between cycles.	99h 59m and 59s or equivalent in any display format.
Grand total run-time	5 x 10 <sup>6</sup> hours maximum

### Clock

Timekeeping accuracy Less than ±0.43s error per day over operating temperature range.

### Environmental

Operating temp	-40 to +70°C display -20 to +70°C
Storage temp	-40 to +85°C
Humidity	to 95% at 40°C non condensing
Vibration	Report available
Enclosure Material	Noryl SE1GFN3
Protection	Front IP66, rear IP20
EMC	Complies with EMC Directive 2014/30/EU

### Mechanical

Terminals	Screw clamp for 0.5 to 1.5mm <sup>2</sup> cable, removable.
Weight	0.15kg

### Accessories

Backlight	Green LED internally powered
-----------	------------------------------

Control outputs	Two outputs each of which may be independently configured as a NO or NC output.
-----------------	---

Outputs	Isolated single pole, voltage free solid state switch.
Ron	5Ω + 0.7V max
Roff	1MΩ min
V max	30V dc
I max	200mA

Scale card	Blank card fitted to all instruments. Can be supplied printed with specified units of time for no additional charge at time of purchase. #
------------	--

Tag legend	Specified tag number or application printed onto rear of instrument. #
------------	--

BA495 rear cover and sealing kit	Provides impact and IP66 protection for rear of instrument. #
----------------------------------	---

# See accessory datasheet for details

## DIMENSIONS (mm)

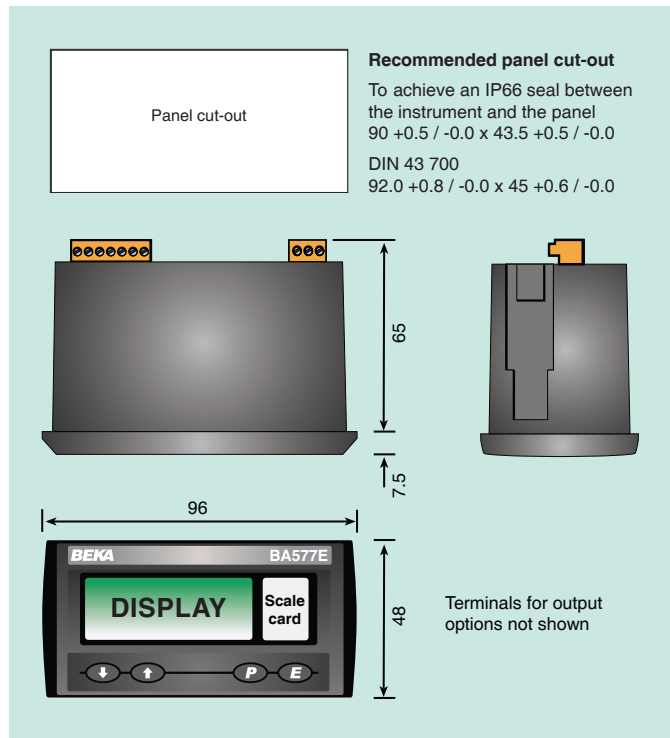

## TERMINAL CONNECTIONS

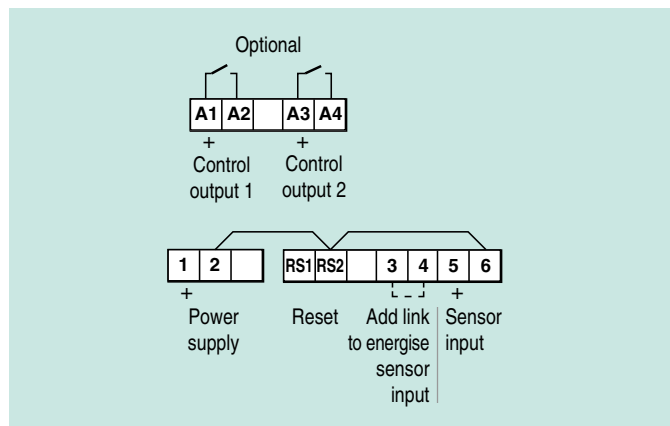

## HOW TO ORDER

Model number  
Function  
Input

**Please specify**  
BA577E  
Timer or Clock  
Type \*

### Accessories

Display backlight  
Control outputs  
Scale card  
  
Tag  
Rear cover and sealing kit

### Please specify if required

Backlight  
Control outputs  
Legend required  
*No charge if ordered with instrument*  
Legend required  
BA495

\* BA577E can be supplied configured as required for no additional charge, see instruction manual, which can be downloaded from [www.beka.co.uk/ba577e](http://www.beka.co.uk/ba577e) for details. If configuration information is not supplied, instrument will be configured as a Timer with an open collector input. Can easily be reconfigured on-site.