

The **BA338E** is a third generation intrinsically safe rate totaliser that is compatible with the earlier BA338C, but has a much larger display, a lineariser and an isolated synchronous pulse output. The totaliser is easy to use and can be configured on-site to operate with flowmeters having a magnetic pick-off, switch contact, proximity detector, open collector or a voltage pulse output. A slide-in scale card simplifies identification and international intrinsic safety certification permits worldwide installation.

**Main application** of the BA338E is to process the pulse output from a hazardous area flowmeter such as a turbine meter and simultaneously display the rate and total flow in engineering units within the hazardous area. The BA338E will compensate for flowmeter nonlinearity using up to sixteen flowmeter K-factors which can be entered on-site.

**The large display** has high contrast and a very wide viewing angle enabling the rate totaliser to be read in most lighting conditions over a wide temperature range. Rate of flow may be displayed in almost any units of measurement per second, minute or hour. Total flow may be shown in the same or in different units and the total display may be reset using the front panel push buttons or an external contact closure.

**IP66 front panel protection** with a neoprene gasket to seal the joint between the totaliser and the instrument panel allow the BA338E to be installed in areas that will be washed down. To simplify installation and maintenance, the totaliser has removable terminal blocks allowing panel wiring to be completed before the instrument is installed.

**Open collector pulse output** will synchronously retransmit the rate totaliser input pulse, or a pulse when the least significant digit of the total display is incremented.

**International intrinsic safety certification** allows the BA338E rate totaliser to be installed worldwide. When configured to operate with a flowmeter having a voltage or magnetic pick-off output, the input terminals comply with the requirements for *simple apparatus* reducing system design and documentation. All input safety parameters are the same or greater than those for the preceding BA338C, thus allowing the BA338E to safely replace the earlier model.

**Display backlighting**, which is internally powered from the totaliser, is available as a factory fitted option. It provides green background illumination enhancing daylight viewing and allowing the display to be easily read at night or when the totaliser is installed in a poorly illuminated area.

**An optional isolated 4/20mA output** may be configured to produce an analogue output proportional to any part of the rate or total display. The output is galvanically isolated and has been certified as a separate intrinsically safe circuit complying with the requirements for *simple apparatus* thus simplifying connection to other instruments.

**Optional dual alarms** can switch hazardous area loads such as a sounder or solenoid valve, or safe area loads via a Zener barrier or isolator. The two galvanically isolated, solid state voltage free outputs may be independently conditioned as rate or total alarms with normally open or closed outputs. Annunciators on the BA338E display show the status of both alarm outputs.

When panel space is limited the BA337E provides similar features in a smaller 94 x 48mm enclosure.

# BA338E

## One input rate totaliser

*Intrinsically safe for use in all gas hazardous areas*

- ◆ **Configurable input:** magnetic pick-off, switch contact, proximity detector, open collector or voltage pulse.
- ◆ **Separate rate and total displays.**
- ◆ **Intrinsically safe**
- ◆ **144 x 72mm DIN enclosure with IP66 front protection.**
- ◆ **Lineariser**
- ◆ **Isolated pulse output**
- ◆ **Optional:** Backlight, Dual alarms, 4/20mA output
- ◆ **3 year guarantee**

[www.beka.co.uk/ba338e](http://www.beka.co.uk/ba338e)



# BEKA associates

BEKA associates Ltd. Old Charlton Rd.  
Hitchin, Hertfordshire, SG5 2DA, U.K.  
Tel. (01462) 438301 e-mail [sales@beka.co.uk](mailto:sales@beka.co.uk)  
website: [www.beka.co.uk](http://www.beka.co.uk)

## SPECIFICATION

<b>Power supply</b>		
Voltage	10 to 28V from a Zener barrier or galvanic isolator	
Current	16mA max plus 16mA for optional backlight	
<b>Input</b>	<b>Lower</b>	<b>Upper</b> switching thresholds
Switch contact	100Ω	1kΩ
Proximity detector (NAMUR)	1.2mA	2.1mA
Open collector	2kΩ	10kΩ
Magnetic pick-off	0	+40mV
Voltage pulse (low)	1V	3V 28V max
Voltage pulse (high)	3V	10V 28V max
<b>Frequency</b>		
Switch contact	150Hz typical	] Depends upon pulse width & debounce setting.
Other inputs	100kHz max	
All inputs	0.01Hz min	
<b>Display</b>		
Type	Liquid crystal	
Zero blanking	Blanked apart from 0 in front of decimal point	
Total #	8 digits 18mm high	
Decimal point	1 of 7 positions or absent	
Rate #	6 digits 12mm high	
Decimal point	1 of 4 positions or absent	
# Rate & Total can be shown on either 6 or 8 digit display		
Grand total	Maximum count 10 <sup>16</sup>	
<b>Remote reset</b>	Contact closure with resistance less than 10kΩ	
<b>Pulse output</b>	Isolated open collector, certified as a separate intrinsically safe circuit complying with the requirements for <i>simple apparatus</i> .	
Source	Totaliser input: synchronous pulse output, 5kHz max. or Least significant digit of total display: pulse output divisible by 1, 10, 100, 1000 or 10000; pulse width definable as 0.1, 0.5, 1, 2.5, 5, 10, 25, 50, 100, 250 or 500ms.	
Ron	51Ω + 3V max	
Roff	1MΩ min	
I max	10mA	
<b>Configurable functions</b>		
Rate scale factor	Adjustable between 0.0001 and 99999 pulses/unit vol.	
Flowmeter K-factor	Up to 16 K-factors may be entered	
Lineariser	Rate may be displayed per second, minute or hour	
Rate timebase	Adjustable digital filter	
Rate display filter	Adjustable between 0.0001 and 99999	
Total scale factor		
<b>Intrinsic safety</b>		
<b>International IECEx</b>		
Code	Ex ia IIC T5 Ga	
	-40°C ≤ Ta ≤ 70°C	
Cert. No.	<a href="#">IECEX ITS 16.0004X</a>	
<b>Europe ATEX and UKEX</b>		
Code	Group II Category 1G Ex ia IIC T5 Ga	
	-40°C ≤ Ta ≤ 70°C	
Cert. No.s	<a href="#">ITS16ATEX28408X</a> & <a href="#">ITS21UKEX0098X</a>	
<b>ETL &amp; cETL</b>		
Code	Class I Div 1 Gp A, B, C, D T5 (USA & Canada)	
	Class II Div 1 Gp E, F, G. Class III Div 1(USA & Canada)	
	Class I Zone 0 AEx ia IIC T5 Ga (USA)	
	Ex ia IIC T5 Ga (Canada)	
	-40°C ≤ Ta ≤ 70°C	
ETL Control No.	<a href="#">4008610</a>	
<b>China CCC</b>	As IECEx - <a href="#">see certificate</a>	
<b>India CCOE/PESO</b>	As ATEX - <a href="#">see certificate</a>	
<b>Nonincendive USA &amp; Canada ETL &amp; cETL</b>		
Code	Class I Div 2 Gp A, B, C, D T5	
	Class II Div 2 Gp F, G. Class III Div 2	
	-40°C ≤ Ta ≤ 70°C	
ETL Control No.	<a href="#">4008610</a>	
<b>Environmental</b>		
Operating temp	-40 to +70°C display -20 to +70°C	
Storage temp	-40 to +85°C	
Humidity	to 95% at 40°C non condensing	
Vibration	Report available	
Enclosure	Noryl SE1GFN3. Front IP66, rear IP20	
EMC	Complies with EU and UK Directives	
<b>Mechanical</b>		
Terminals	Screw clamp for 0.5 to 1.5mm <sup>2</sup> cable, removable terminal blocks.	
Weight	0.35kg	
<b>Accessories</b>		
Backlight	Green LED internally powered	
4/20mA output	Isolated current sink, certified as a separate intrinsically safe circuit complying with requirements for <i>simple apparatus</i> .	
Voltage drop	5 to 28V	
Alarms	Two alarms each of which may be independently configured as a rate or total, high or low alarm with a NO or NC output.	
Outputs	Isolated single pole, voltage free solid state switch, each certified as a separate intrinsically safe circuit complying with the requirements for <i>simple apparatus</i> .	
Ron	5Ω + 0.7V max	
Roff	1MΩ min	

## DIMENSIONS (mm)

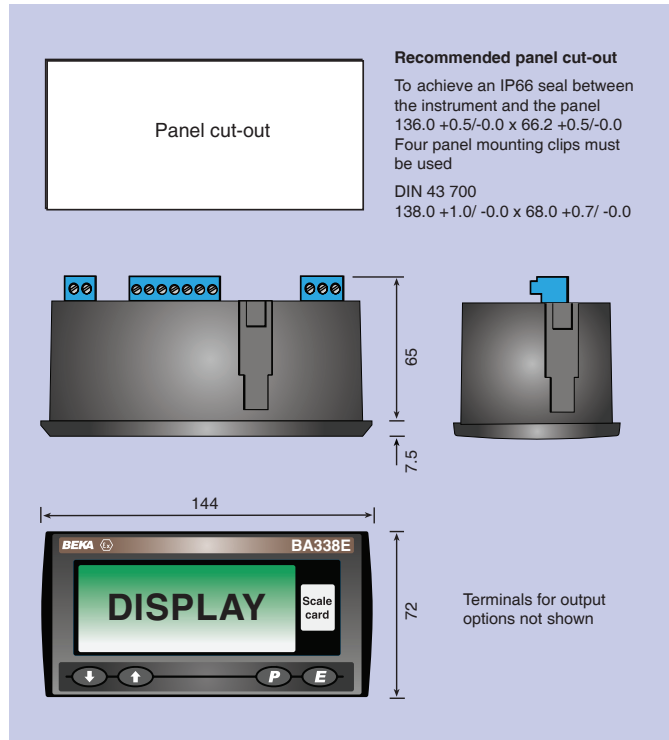

## TERMINAL CONNECTIONS

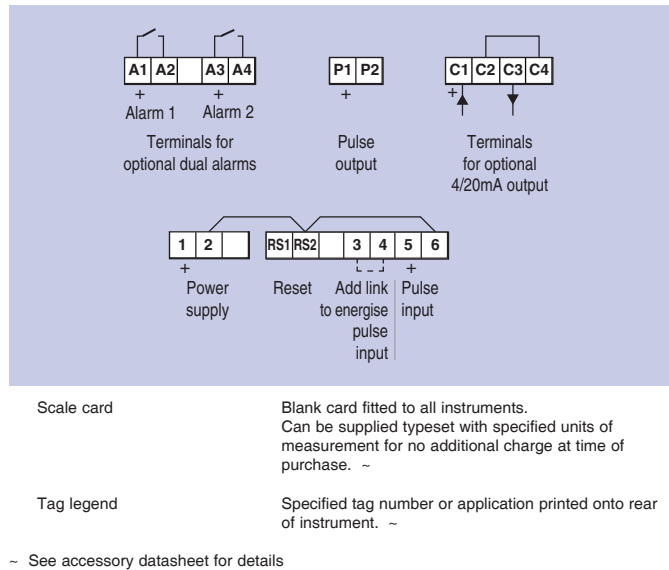

## HOW TO ORDER

Model number	<b>Please specify</b> BA338E
Input	Type *
Rate scale factor	XXXXX * If linearisation is required, up to 16 rate scale factors may be entered each at a specified flow rate.
Rate timebase	Seconds, minutes or hours*
Total scale factor	XXXXX *
Pulse output	Direct retransmission or derived from least significant digit of total display: pulse output divided by 1, 10, 100, 1000 or 10000; pulse width defined as 0.1, 0.5, 1, 2.5, 5, 10, 25, 50, 100, 250 or 500ms.*
<b>Accessories</b>	<b>Please specify if required</b>
Display backlight	Backlight
4/20mA output	4/20mA output
Dual alarms	Alarms
Scale card	Legend required
Tag	No charge if ordered with totaliser. Legend required

\* Totaliser can be supplied configured as required for no additional charge. If configuration information is not supplied, instrument will be configured for open collector input with rate and total scaling factors of 1.0 and a timebase of minutes with direct pulse retransmission. Can easily be reconfigured on-site.