

The **BA314E** is a third generation intrinsically safe field mounting tachometer housed in a robust IP66 GRP enclosure. The BA314E supersedes the BA364D. The tachometer is easy to use and can be configured on-site to operate with a magnetic pick-off, switch contact, proximity detector, open collector or a voltage pulse sensor. International intrinsic safety certification permits worldwide installation.

The **main application** of the BA314E is to measure and display rotational speed within a hazardous area. To assist with routine maintenance, the BA314E tachometer includes a run-time clock that records the number of hours that the monitored machinery has been operating.

**International intrinsic safety certification** allows the BA314E tachometer to be installed in gas hazardous areas worldwide. When configured to operate with a sensor having a voltage or magnetic pick-off output, the tachometer's input terminals comply with the requirements for *simple apparatus* reducing system design and documentation.

The **display** has high contrast and a wide viewing angle. Green backlighting enhances daylight viewing and allows the instrument to be easily read at night or when installed in a poorly illuminated area. Speed may be displayed in almost any units of measurement per second, minute or hour. Run-time is shown on the lower display in hours with a tenth of an hour resolution. If not required, the run-time display may be disabled.

**IP66 protection** is provided by the robust GRP enclosure which has stainless steel fittings, silicone gaskets and a 4mm thick armoured glass window. Ingress and impact protection have been independently assessed by Intertek. A separate terminal compartment allows connection of field wiring without exposing the instrument electronics.

The **isolated open collector pulse output** which complies with the requirements for *simple apparatus*, synchronously retransmits the tachometer's input pulse to other instruments. The retransmitted output pulse frequency may be divided and the output pulse width may be defined.

The **isolated 4/20mA output** which also complies with the requirements for *simple apparatus*, may be configured to produce an output proportional to any part of the speed display.

**Dual alarms** can switch hazardous area loads such as a sounder or a solenoid valve, or safe area loads via a Zener barrier or isolator. The two galvanically isolated, solid state voltage free outputs may be independently configured as speed or run-time alarms, with normally open or closed outputs. Annunciators on the tachometer display show the status of both alarm outputs.

The **display escutcheon** can be marked to show the BA314E tachometer's units of measurement and tag information. New instruments are supplied with a printed escutcheon showing customer specified marking, if this information is not supplied when the instrument is ordered, a blank escutcheon is fitted which can easily be marked on-site. An optional laser engraved stainless steel legend plate secured to the front of the instrument is also available.

**When space is limited** the compact BA314G is a smaller version of the BA314E, it has the same functions, but it does not have a separate terminal compartment.

**For installation in Zone 2 or 22** without the need for Zener barriers or galvanic isolators, the BA314NG is similar to the BA314E but has Ex nA and Ex tc certification.

**Panel mounting tachometers** with similar specifications are available in a variety of sizes and material for use in hazardous and safe areas.

# BA314E

## One input tachometer

*Intrinsically safe for use in all gas hazardous areas*

- ◆ **Configurable input:** magnetic pick-off, switch contact, proximity detector, open collector or voltage pulse.
- ◆ **Separate speed and run-time displays.**
- ◆ **Intrinsically safe**
- ◆ **IP66 GRP enclosure with separate terminal compartment.**
- ◆ **Isolated dual alarms, pulse and 4/20mA outputs.**
- ◆ **3 year guarantee**

[www.beka.co.uk/ba314e](http://www.beka.co.uk/ba314e)



# BEKA

## associates

BEKA associates Ltd. Old Charlton Rd. Hitchin, Hertfordshire, SG5 2DA, U.K.  
Tel. (01462) 438301 Fax (01462) 453971  
e-mail [sales@beka.co.uk](mailto:sales@beka.co.uk) [www.beka.co.uk](http://www.beka.co.uk)

## SPECIFICATION

<b>Power supply</b>	
Voltage	10 to 28V from a Zener barrier or galvanic isolator
Current	32mA
<b>Input</b>	
	<b>Lower                      Upper</b> switching thresholds
Switch contact	100Ω                      1kΩ
Proximity detector (NAMUR)	1.2mA                    2.1mA
Open collector	2kΩ                        10kΩ
Magnetic pick-off	0                            +40mV
Voltage pulse (low)	1V                         3V    28V max
Voltage pulse (high)	3V                        10V   28V max
Frequency	
Switch contact	150Hz typical } <i>Depends upon pulse width</i>
Other inputs	100kHz max    } <i>and debounce setting.</i>
All inputs	0.01Hz min
<b>Display</b>	
Type	Liquid crystal
Zero blanking	Blanked apart from 0 in front of decimal point
Speed	
Digits	8 digits 18mm high
Decimal point	1 of 7 positions or absent
Run-time	
Digits	6 digits 12mm high, 99999.9 hours max
Grand total run-time	5 x 10 <sup>6</sup> hours max
<b>Remote reset</b>	
	Contact closure with resistance less than 10kΩ
<b>Configurable functions</b>	
Speed scale factor	Adjustable between 0.0001 and 99999 pulses / revolution.
Speed timebase	Speed may be displayed per second, minute or hour
<b>Pulse output</b>	
Frequency	Isolated open collector 5kHz max, synchronous with input pulse, or divisible with defined pulse width.
Divisible by	1, 10, 100, 1000 or 10000
Pulse width	0.1, 0.5, 1, 2.5, 5, 10, 25, 50, 100, 250 or 500ms
Ron	51Ω + 3V max
Roff	1MΩ min
I max	10mA
<b>4/20mA output</b>	
	Isolated current sink, configurable to represent any part of the speed display.
Voltage drop	5 to 28V
<b>Dual alarms</b>	
	Two alarms each of which may be independently configured as a speed or run-time, high or low alarm with a NO or NC output.
Outputs	
Ron	Isolated single pole, voltage free solid state switch 5Ω + 0.7V max
Roff	1MΩ min
<b>Intrinsic safety</b>	
<b>Europe ATEX</b>	
Code	Group II Category 1G Ex ia IIC T5 Ga
	-40 ≤ Ta ≤ 70°C
Cert. No.	ITS16ATEX28408X
<b>International IECEx</b>	
Code	Ex ia IIC T5 Ga
	-40 ≤ Ta ≤ 70°C
Cert. No.	IECEx ITS 16.0004X
<b>ETL &amp; cETL</b>	
Code	Class I Div 1 Gp A, B, C, D T5 Class II Div 1 Gp E, F, G Class III Class I Zone 0 AEx ia IIC T5 Ga Zone 20 AEx ia IIC T80°C Da Ex ia IIC T5 Ga -40°C ≤ Ta ≤ 70°C
	} USA & Canada } USA } Canada
<b>Nonincendive USA &amp; Canada ETL &amp; cETL</b>	
Code	Class I Div 2 Gp A, B, C, D T5 Class II Div 2 Gp F, G Class III Div 2 -40°C ≤ Ta ≤ 70°C
ETL Control No.	4008610
<b>Environmental</b>	
Operating temp	-40 to +70°C display -20 to +70°C
Storage temp	-40 to +85°C
Humidity	to 95% at 40°C non condensing
Vibration	Report available
Enclosure	
Material	GRP
Ingress	IP66
EMC	Complies with 2014/30/EU
<b>Mechanical</b>	
Terminals	Screw clamp for 0.5 to 1.5mm <sup>2</sup>
Weight	1.7kg

## DIMENSIONS (mm)

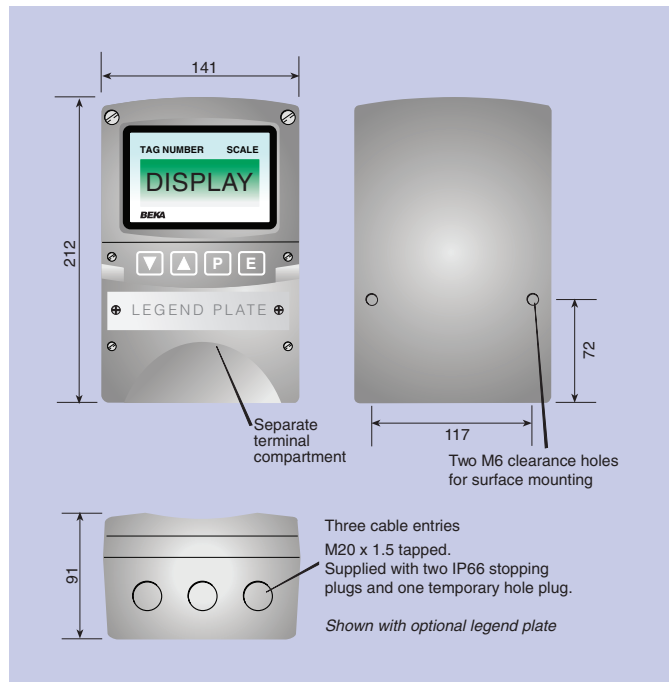

## TERMINAL CONNECTIONS

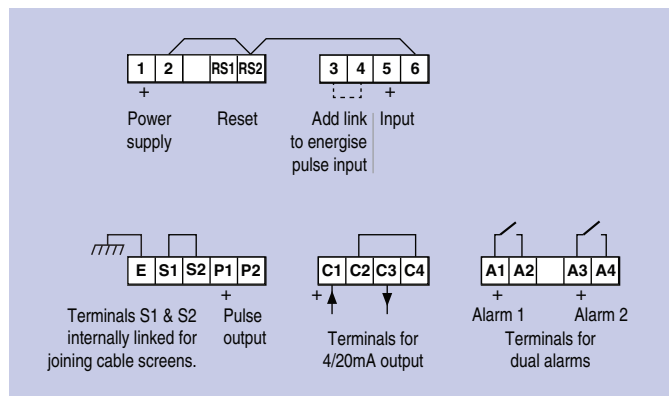

### Accessories

Escutcheon	Blank card fitted to all instruments. Can be supplied printed with specified units of measurement and tag information for no additional charge at time of purchase. #
Legend plate	316 stainless steel plate secured to the front of the instrument laser engraved with tag number or application information. #
Pipe mounting kit	BA392D or BA393 #

# See accessory datasheet for details

## HOW TO ORDER

Model number	<b>Please specify</b> BA314E
Input	Type *
Speed scale factor	XXXXX *
Speed timebase	Seconds, minutes or hours*
<b>Accessories</b>	
Scale card marking	<b>Please specify if required</b>
Units	Legend required
Tag	Legend required
	<i>No charge if ordered with tachometer</i>
Stainless legend plate	Legend required
Pipe mounting kit	BA392D or BA393

\* Tachometer can be supplied configured as required for no additional charge. If configuration information is not supplied, instrument will be configured for open collector input with speed scaling factor of 1.0 and a timebase of minutes with direct pulse retransmission. Can easily be reconfigured on-site.