

BA618CF
Panel mounting
Fieldbus Indicator
Issue 1

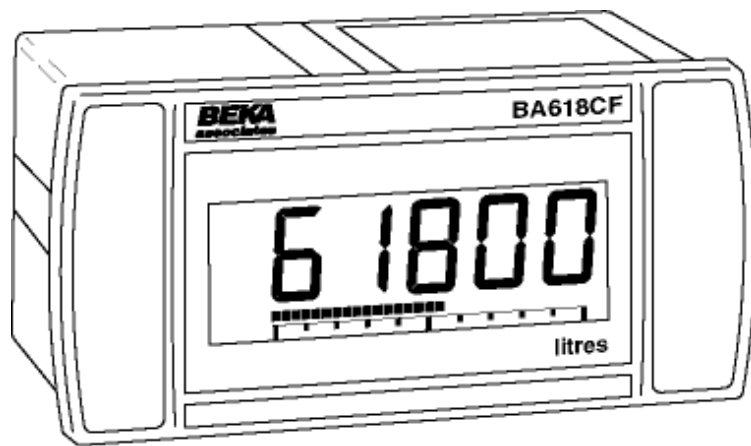

CONTENTS

1. Description

- 1.1 Documentation

2. System Design

3. Installation

- 3.1 Location
- 3.2 Installation procedure
- 3.3 EMC

4. Maintenance

- 4.1 Fault finding during commissioning
- 4.2 Fault finding after commissioning
- 4.3 Servicing
- 4.4 Routine maintenance
- 4.5 Guarantee
- 4.6 Customer comments

5. Accessories

- 5.1 Scale marking
- 5.2 Tag number
- 5.3 Fieldbus Interface Guide

1. DESCRIPTION

The BA618CF Fieldbus Indicator is a FOUNDATION Fieldbus™ instrument that can display one fieldbus process variable on a five digit LCD and 31 segment analogue bargraph. The instrument is bus powered so no additional power supply is required.

Communication Protocol	Fieldbus Function Block
FOUNDATION Fieldbus	Input Selector (1 x IS)

The Device Description files may be downloaded from The Fieldbus Foundation or the BEKA associates web site at www.beka.co.uk.

Housed in a robust 72 x 144 panel mounting DIN enclosure, the BA618CF fieldbus indicator has an IP66 front panel and is supplied with a gasket to seal the joint between the instrument and the panel.

1.1 Documentation

This instruction manual describes system design and installation of the BA618CF Fieldbus Indicator. For commissioning information please refer to:

FOUNDATION Fieldbus
Fieldbus Interface Guide
for
Fieldbus Displays and
Fieldbus Indicators

which can be requested via the BEKA web site at www.beka.co.uk

2. SYSTEM DESIGN

The BA618CF indicator is powered and communicates via the fieldbus which is connected to non-polarised terminals 1 and 2. As shown in Fig 1 the instrument may be connected to any fieldbus segment which can supply the additional 13mA required to power the instrument.

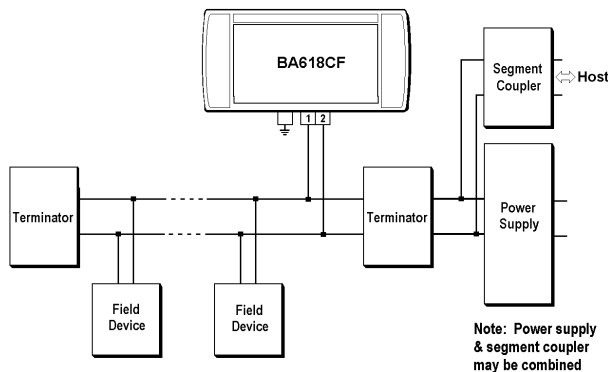

Fig 1 Fieldbus system

3. INSTALLATION

3.1 Location

The BA618CF is housed in a robust aluminium enclosure with a toughened glass window mounted in a Noryl bezel. The front of the instrument provides IP66 protection and a gasket seals the joint between the instrument enclosure and the panel. The instrument may be installed in any panel providing the environmental limits shown in the specification are not exceeded.

Fig 2 shows the overall dimensions of the BA618CF and the panel cut-out. To achieve an IP66 seal between the instrument enclosure and the panel, the smaller cut-out must be used and the instrument secured with four panel mounting clips.

The BA618CF liquid crystal display has maximum contrast when viewed from directly ahead and slightly below the centre line of the instrument.

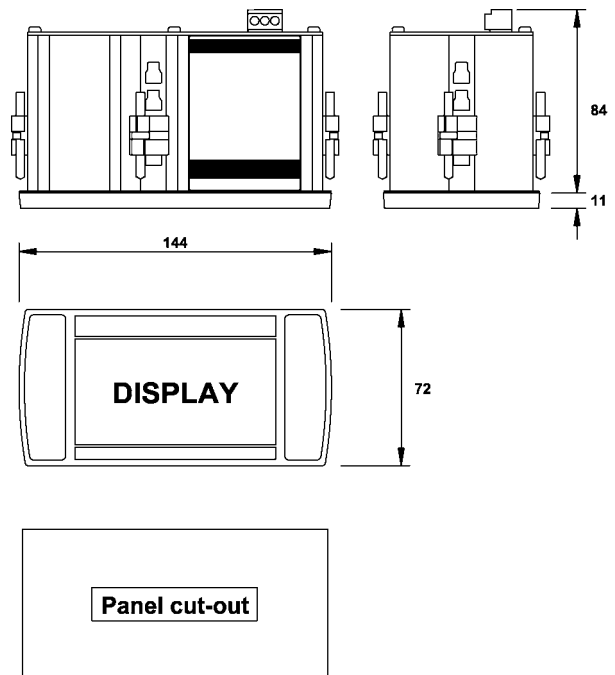

Cut-out Dimensions

DIN 43 700
138.0 +1.0/-0.0 x 68.0 +0.7/-0.0

To achieve an IP66 seal between instrument enclosure and panel
136.0 +0.5/-0.0 x 66.2 +0.5/0.0

Fig 2 BA618CF dimensions

3.2 Installation Procedure

- a. Insert the BA618CF into the instrument panel cut-out from the front of the panel.
- b. Fix panel mounting clips to opposite sides of the instrument and tighten until the instrument is secure. Four clips are required to achieve an IP66 seal between the instrument enclosure and the panel.
- c. Connect the panel wiring to the rear terminal block as shown in Fig 3. To simplify installation, the terminals are removable so that panel wiring can be completed before the instrument is installed.

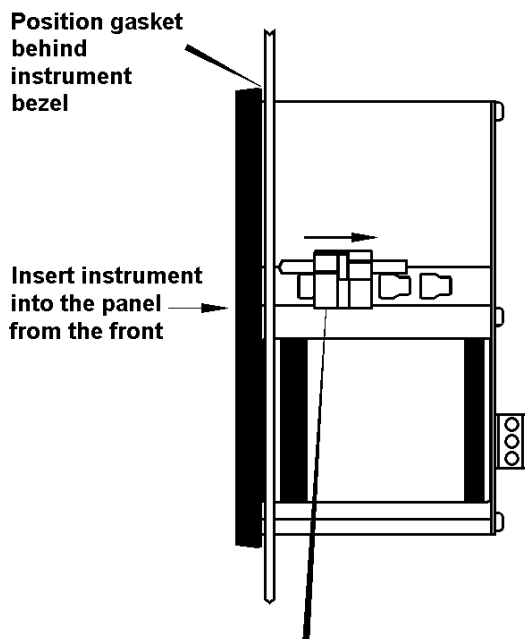

Slide panel mounting clip into the slotted rail on the side of the enclosure. Four clips are required to achieve an IP66 seal between instrument and panel.

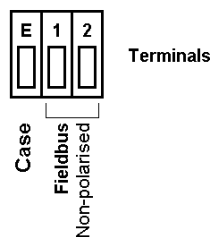

Fig 3 Installation and terminal connections

3.3 EMC

The BA618CF complies with the requirements of the European EMC Directive 89/336/EEC. For specified immunity, all wiring should be in screened twisted pairs with the screens earthed at one point.

4. MAINTENANCE

4.1 Fault finding during commissioning

If a BA618CF fails to function during commissioning the following procedure should be followed:

Symptom	Cause	Check:
No Display	Instrument not correctly connected or powered.	9 to 32V between terminals 1 & 2.
Display shows '9.9.9.9.9' with all decimal points flashing; all bargraph segments activated and bargraph scale flashing.	Value over-range	Variable source Decimal point configuration.
Display shows '-9.9.9.9.9' with all decimal points flashing; no bargraph segments activated and bargraph scale flashing.	Value under-range	Variable source Decimal point configuration
Display alternates between value and the word 'bAd'. Bargraph flashes.	Status of fieldbus variable has a quality of 'BAD' or a fault state is active. Display has not yet received data.	Variable source Fieldbus configuration.
Bargraph scale flashes.	Variable is outside the limits defined for the bargraph.	Bargraph configuration.
All display segments activated.	Display is initialising.	This is normal operation, after a few seconds the firmware version will be displayed prior to entering the operational mode.

4.2 Fault finding after commissioning

ENSURE PLANT SAFETY BEFORE STARTING MAINTENANCE

If a BA618CF fails after it has been functioning correctly, the table shown in section 5.1 may help to identify the cause of the failure.

If this procedure does not reveal the cause of the fault, it is recommended that the instrument is replaced.

4.3 Servicing

We recommend that faulty BA618CF Fieldbus Indicators be returned to BEKA associates or to our local agent for repair.

4.4 Routine maintenance

The mechanical and electrical condition of the instrument should be regularly checked. Initially annual inspections are recommended, but the inspection frequency should be adjusted to suit the environmental conditions.

4.5 Guarantee

Instruments which fail within the guarantee period should be returned to BEKA associates or our local agent. It is helpful if a brief description of the fault symptoms is provided.

4.6 Customer comments

BEKA associates is always pleased to receive comments from customers about our products and services. All communications are acknowledged and whenever possible, suggestions are implemented.

5. ACCESSORIES

5.1 Scale marking

BA618CF indicators are fitted with a blank escutcheon around the liquid crystal display. If specified when the instrument is ordered, this can be supplied printed with units of measurement.

5.2 Tag number

The BA618CF can be supplied with a thermally printed tag number on the rear panel adjacent to the terminals.

5.3 Fieldbus Interface Guide

The *FOUNDATION Fieldbus Interface Guide for Fieldbus Displays & Fieldbus Indicators* contains commissioning information for the BA618CF. A copy may be requested from the BEKA sales office or from the BEKA web site at www.beka.co.uk