

The BA488CF-P Fieldbus Display is an intrinsically safe instrument that can display up to eight fieldbus process variables. Eleven selectable standard screen formats contain one, two, three, four or eight variables, with units of measurement, tag descriptions and bargraphs on some screens.

Powered by the fieldbus the BA488CF-P only requires a 2-wire connection, no additional power supply Zener barriers or galvanic isolators are required. The high contrast 86 x 45mm liquid crystal display incorporates a green backlight that is also powered from the fieldbus enabling the display to be read in all lighting conditions from full sunlight to total darkness.

Simple commissioning results from the use of standard display formats. Apart from loading the BA488CF-P configuration files onto the system host and selecting the fieldbus variables to be displayed, no programming is required. Configuration of the BA488CF-P Fieldbus Display is performed via the fieldbus and the instrument front panel push buttons.

ATEX, FM & IECEx intrinsic safety certification allows the BA488CF-P to be installed in gas hazardous areas worldwide. The two fieldbus terminals comply with the Fieldbus Intrinsic Safety Concept (FISCO) simplifying system design and documentation, although connection to non-FISCO intrinsically safe segments is possible using the entity concept. This allows a BA488CF-P to be directly connected to almost any hazardous fieldbus providing the

segment can supply the 25mA consumed by the display.

Six optional local alarm outputs may be linked to any of the displayed variables. Each isolated single pole solid state output may be conditioned as a combined high and low alarm, or as just a high or low alarm. All the outputs comply with the requirements for simple apparatus allowing them to switch any certified intrinsically safe load such as a sounder, lamp or solenoid valve. Alarm configuration and the alarm set point adjustment is performed via the BA488CF-P front panel push buttons, as the local alarms are not accessible from the fieldbus system host

The six push buttons on the front of the instrument may be used for returning operator acknowledgments or controls to the fieldbus host. If larger industrial switches are required for these operator controls, up to six external push buttons may be connected to the BA488CF-P. When the external switches are activated, the front panel push buttons may be disabled or operated in parallel with the external switches.

Comprehensive documentation includes a PROFIBUS Interface Guide.

For field mounting applications see the BA484DF-P datasheet. This instrument has a similar electrical specification but is housed in a robust IP66 GRP enclosure suitable for external mounting.

For FOUNDATION™ fieldbus systems, please see the datasheet for the equivalent BA488CF-F fieldbus display.

BA488CF-P

PROFIBUS PA Fieldbus display 8 variables

*Intrinsically safe for use
in all gas hazardous
areas*

- ◆ PROFIBUS PA protocol
- ◆ Compatible with most system hosts
- ◆ High contrast display with backlight
- ◆ Intrinsically safe ATEX, FM & IECEx certification FISCO compliant
- ◆ Six operator push buttons & six optional local alarm outputs
- ◆ IP66 front panel
- ◆ 3 year guarantee



BEKA associates

BEKA associates Ltd. Old Charlton Rd.
Hitchin, Hertfordshire, SG5 2DA, U.K.
Tel. (01462) 438301 Fax (01462) 453971
e-mail sales@beka.co.uk www.beka.co.uk

SPECIFICATION

Display

Type	120 x 64 pixel liquid crystal
Size	86.5mm x 45mm
Backlight	Powered from fieldbus
Screens	
Standard format	1, 2, 3, 4 or 8 variables plus bargraph can include: units of measurement tag information

Controls

Front panel	Six push buttons scroll the indicator display between screens when the BA488CF-P is configured to display more variables than fit onto a single screen. Also used to configure optional local alarms and may be used to return operator inputs to the system host. Control may be transferred to six external switches; front panel buttons may be inhibited or operated in parallel.
External switches	5m max length.
Switch cable	

Fieldbus communication

Voltage	9 to 32V (Limited by intrinsic safety parameters)
Current	25mA
Compliant with Protocol	IEC61158—2 Clauses 11 and 22 PROFIBUS PA
Function blocks	8 x AO (Analogue Output) 6 x DI (Digital Input)

Intrinsic safety

Europe ATEX

Code	Group II Category 1G Ex ia IIC T4				
Cert. No.	ITS04ATEX22779				
Intrinsic safety parameters	<table> <tr> <td>$U_i = 17.5V$</td> <td rowspan="3">FISCO compliant</td> </tr> <tr> <td>$I_i = 380mA$</td> </tr> <tr> <td>$P_i = 5.32W$</td> </tr> </table>	$U_i = 17.5V$	FISCO compliant	$I_i = 380mA$	$P_i = 5.32W$
$U_i = 17.5V$	FISCO compliant				
$I_i = 380mA$					
$P_i = 5.32W$					
Location	Zone 0, 1 or 2				

USA FM

Standard Code	3610 Entity CL I; Div 1; GP A, B, C & D T4 @ 60°C
File No	3022546
Standard Code	3611 Nonincendive CL I; Div 2; GP A, B, C & D T4 @ 60°C
File No	3022546

International IECEx

Standard Code	IEC60079-11:1999 Ex ia IIC T4 Ta = -40 to 60°C
Cert. No.	IECEx ITS 05.0007

Environmental

Operating temp	-20 to +60°C (certified for use at -40°C)
Storage temp	-40 to 85°C
Humidity	To 95% @ 40°C
Enclosure	Front IP66, rear IP20
EMC	In accordance with EU Directive 2004/108/EC BS EN 61326:1998
Immunity	Operates normally with conducted 3Vrms interference between 0.15kHz and 80MHz, or radiated 10V/m interference between 80MHz and 1GHz.
Emissions	CISPR 16-1/2 Class A

Mechanical

Terminals	Removable with screw clamp for 0.5 to 1.5mm ² cable.
Weight	0.7kg

Accessories

Alarms	Six galvanically isolated outputs which may be linked to displayed variables. Each alarm is configurable from instrument push buttons as: combined high and low alarm high or low alarm Note: Alarms are not accessible from the fieldbus system host
Contacts	Isolated single pole solid state switch certified as simple apparatus. Ron less than 5Ω + 0.7V Roff greater than 1MΩ

DIMENSIONS (mm)

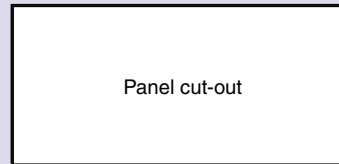

Recommended panel cut-out

DIN 43 700
138.0 +1.0/-0.0 x 68.0 +0.7/-0.0

To achieve an IP65 seal between the instrument and the panel
136.0 +0.5/-0.0 x 66.2 +0.5/-0.0
Four panel mounting clips must be used

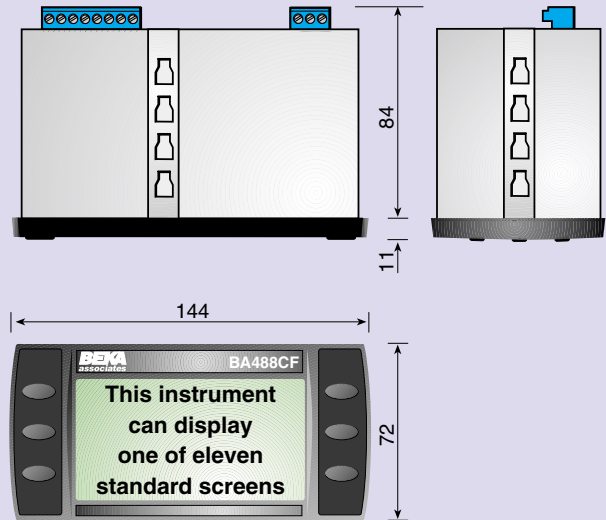

TERMINAL CONNECTIONS

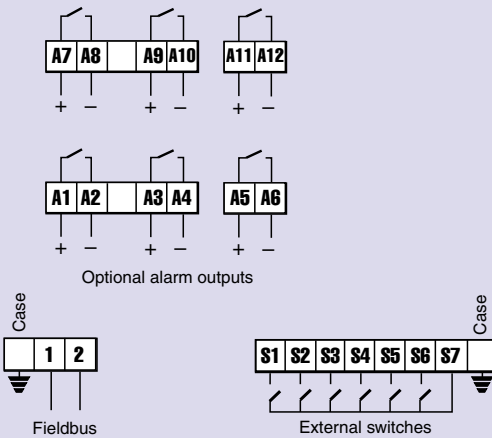

Intrinsic safety parameters

$U_i = 28Vdc$
 $I_i = 200mA$
 $P_i = 0.84W$

Tag number

Thermally printed strip on rear of instrument.

PROFIBUS PA interface guide

May be downloaded from www.beka.co.uk

HOW TO ORDER

Model number

Please specify
BA488CF-P

Accessories

Six alarms
Tag strip

Please specify if required

Alarms
Legend